User's Manual



BTC-2500
Self-Tune Fuzzy / PID
Process / Temperature Controller

BrainChild

Warning Symbol

The Symbol calls attention to an operating procedure, practice, or the like, which, if not correctly performed or adhered to, could result in personal injury or damage to or destruction of part or all of the product and system. Do not proceed beyond a warning symbol until the indicated conditions are fully understood and met.

Use the Manual

- Installers Read Chapter 1, 2
- Basic Function User Read Chapter 1, 3, 5
- Enhanced Function User Read Chapter 1, 3, 4, 5
- System Designer Read All Chapters
- Expert User Read Page 11

CONTENTS

	Page No		Page No
Chapter 1 Overview			
1-1 Features -----	4	3-21 Manual Tuning -----	61
1-2 Ordering Code -----	7	3-22 Signal Conditioner DC Power Supply -----	64
1-3 Programming Port and DIP Switch -----	8	3-23 Manual Control -----	65
1-4 Keys and Displays -----	9	3-24 Display Mode -----	66
1-5 Menu Overview -----	11	3-25 Heater Current Monitoring -----	67
1-6 System Modes -----	12	3-26 Reload Default Values -----	67
1-7 Parameter Description -----	13		
Chapter 2 Installation		Chapter 4 Programming the Full Function	
2-1 Unpacking -----	21	4-1 Event Input -----	68
2-2 Mounting -----	21	4-2 Second Set Point -----	69
2-3 Wiring Precautions -----	22	4-3 Second PID Set -----	70
2-4 Power Wiring -----	23	4-4 Ramp & Dwell -----	71
2-5 Sensor Installation Guidelines -----	24	4-5 Remote Set Point -----	73
2-6 Thermocouple Input Wiring -----	25	4-6 Differential Control -----	74
2-7 RTD Input Wiring -----	26	4-7 Output Power Limits -----	75
2-8 Linear DC Input Wiring -----	26	4-8 Data Communication -----	76
2-9 CT / Heater Current Input Wiring -----	28	4-9 Analog Retransmission -----	77
2-10 Event Input wiring -----	29	4-10 Digital Filter -----	78
2-11 Output 1 Wiring -----	30	4-11 Sleep Mode -----	79
2-12 Output 2 Wiring -----	32	4-12 Pump Control -----	80
2-13 Alarm 1 Wiring -----	34	4-13 Remote Lockout -----	81
2-14 Alarm 2 Wiring -----	35		
2-15 RS-485 -----	36	Chapter 5 Applications	
2-16 RS-232 -----	37	5-1 Pump / Pressure Control -----	82
2-17 Analog Retransmission -----	38	5-2 Variable Period Full Wave SSR (VPFW SSR) -----	84
2-18 Programming Port -----	39	5-3 Heat Only Control -----	86
		5-4 Cool Only Control -----	87
Chapter 3 Programming the Basic Function		5-5 Heat - Cool Control -----	88
3-1 Input 1 -----	40	5-6 Ramp & Dwell -----	90
3-2 OUT1 & OUT2 Types -----	41	5-7 Remote Set Point -----	92
3-3 Rearrange User Menu -----	42	5-8 Differential Control -----	93
3-4 Display SV Instead of PV -----	42	5-9 Dual Set Point / PID -----	94
3-5 Heat Only Control -----	43	5-10 RS-485 -----	96
3-6 Cool Only Control -----	44	5-11 RS-232 -----	98
3-7 Heat - Cool Control -----	45	5-12 Retransmit -----	99
3-8 Dwell Timer -----	47		
3-9 Process Alarms -----	48	Chapter 6 Calibration -----	100
3-10 Deviation Alarms -----	50		
3-11 Deviation Band Alarms -----	51	Chapter 7 Error Codes & Troubleshooting -----	104
3-12 Heater Break Alarm -----	52		
3-13 Loop Break Alarm -----	53	Chapter 8 Specifications -----	107
3-14 Sensor Break Alarm -----	54		
3-15 SP1 Range -----	54	Chapter 9 Modbus Communications -----	110
3-16 PV1 Shift -----	55		
3-17 Failure Transfer -----	56	Appendix	
3-18 Bumpless Transfer -----	57	A-1 Menu Existence Conditions -----	124
3-19 Self-tuning -----	58	A-2 Factory Menu Description -----	127
3-20 Auto-tuning -----	59	A-3 Glossary -----	129
		A-4 Index -----	136
		A-5 Memo -----	139
		A-6 Warranty -----	141

Chapter 1 Overview

1-1 Features

- ** High accuracy 18-bit input A – D
- ** High accuracy 15-bit output D – A
- ** Fast input sample rate (5 times / second)
- ** Two function complexity levels
- ** User menu configurable
- ** Pump control
 - * Fuzzy + PID microprocessor-based control
 - * Automatic programming
 - * Differential control
 - * Auto-tune function
 - * Self-tune function
 - * Sleep mode function
 - * " Soft-start " ramp and dwell timer
 - * Programmable inputs(thermocouple, RTD, mA, VDC)
 - * Analog input for remote set point and CT
 - * Event input for changing function & set point
 - * Programmable digital filter
 - * Hardware lockout + remote lockout protection
 - * Loop break alarm
 - * Heater break alarm
 - * Sensor break alarm + Bumpless transfer
 - * RS-485, RS-232 communication
 - * Analog retransmission
 - * Signal conditioner DC power supply
 - * A wide variety of output modules available
 - * Safety UL / CSA / IEC1010 – 1
 - * EMC / CE EN61326
 - * Front panel sealed to NEMA 4X & IP65

** Unique
* Valuable

BTC-2500 Fuzzy Logic plus PID microprocessor-based controller, incorporates a bright, easy to read 4-digit LED display, indicating process value. The **Fuzzy Logic** technology enables a process to reach a predetermined set point in the shortest time, with the minimum of overshoot during power-up or external load disturbance. The units are housed in a 1/32 DIN case, measuring 24 mm x 48 mm with 98 mm behind panel depth. The units feature three touch keys to select the various control and input parameters. Using a unique function, you can put at most 5 parameters in front of user menu by using **SEL1 to SEL5** contained in the setup menu. This is particularly useful to OEM's as it is easy to configure menu to suit the specific application.

BTC-2500 is powered by 11-26 or 90 - 264 VDC / AC supply, incorporating a 2 amp. control relay output, 5V logic alarm output and a 2 amp. alarm relay output as standard whereby second alarm can be exceptionally configured into second output for cooling purpose or dwell timer. Alternative output options include SSR drive, triac, 4 - 20 mA and 0 - 10 volts. BTC-2500 is fully programmable for PT100, thermocouple types J, K, T, E, B, R, S, N, L, 0 - 20mA, 4 -20mA and voltage signal input, with no need to modify the unit. The input signals are digitized by using a **18-bit A to D** converter. Its **fast sampling rate** allows the BTC-2500 to control fast processes such as pressure and flow. **Self tune** is incorporated. The self- tune can be used to optimize the control parameters as soon as undesired control result is observed. Unlike auto-tuning, Self-tune will produce less disturbance to the process during tuning, and can be used any time.

Digital communications RS-485, RS-232 or 4 - 20 mA retransmission are available as an additional option. These options allow BTC-2500 to be integrated with supervisory control system and software, or alternatively drive remote display, chart recorders or data-loggers.

Three kinds of method can be used to program BTC-2500. 1. Use keys on front panel to program the unit manually, 2. Use a PC and setup software to program the unit via RS-485 or RS-232 COMM port and 3. Use P11A, a hand-held programmer, to program the unit via programming port.

In last nearly a hundred years although PID control has been used and proved to be an efficient controlling method by many industries, yet the PID is difficult to deal with some sophisticated systems such as second and higher order systems, long time-lag systems, during set point change and/or load disturbance circumstance etc. The PID principle is based on a mathematic modeling which is obtained by tuning the process. Unfortunately, many systems are too complex to describe in numerical terms precisely. In addition, these systems may be variable from time to time. In order to overcome the imperfection of PID control, the Fuzzy Technology is introduced. What is the Fuzzy Control? It works like a good driver. Under different speeds and circumstances, he can control a car well with experiences he had before and does not require the knowledge of kinetic theory of motion. The Fuzzy Logic is a linguistic control which is different from the numerical PID control. It controls the system by experiences and does not need to simulate the system precisely as been controlled by PID.

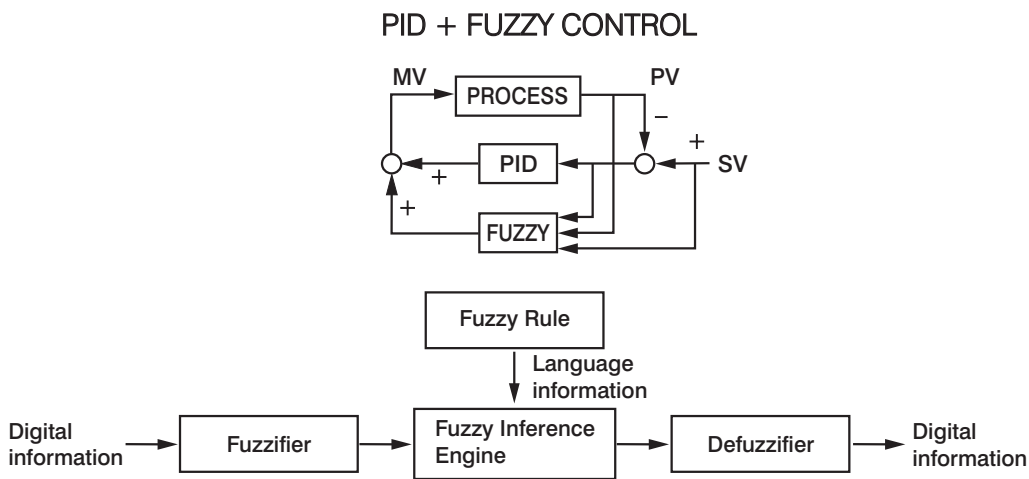

Figure 1.1
Fuzzy PID System Block

The function of Fuzzy Logic is to adjust PID parameters internally in order to make manipulation output value MV more flexible and adaptive to various processes.

The Fuzzy Rule may work like these:

If temperature difference is large, and temperature rate is large, then ΔMV is large.

If temperature difference is large, and temperature rate is small, then ΔMV is small.

⋮

PID + Fuzzy Control has been proven to be an efficient method to improve the control stability as shown by the comparison curves below:

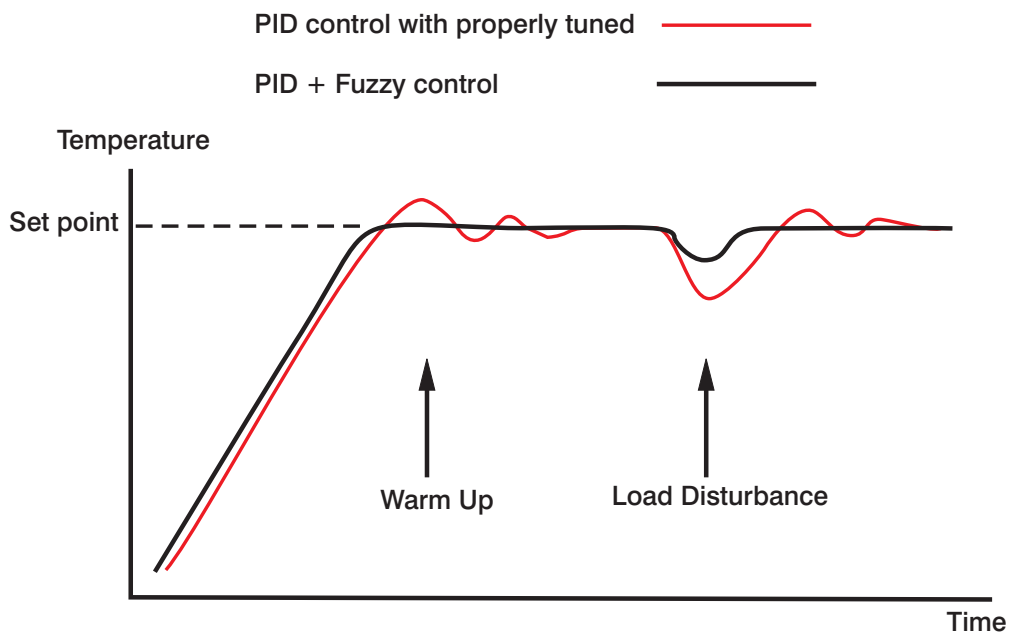
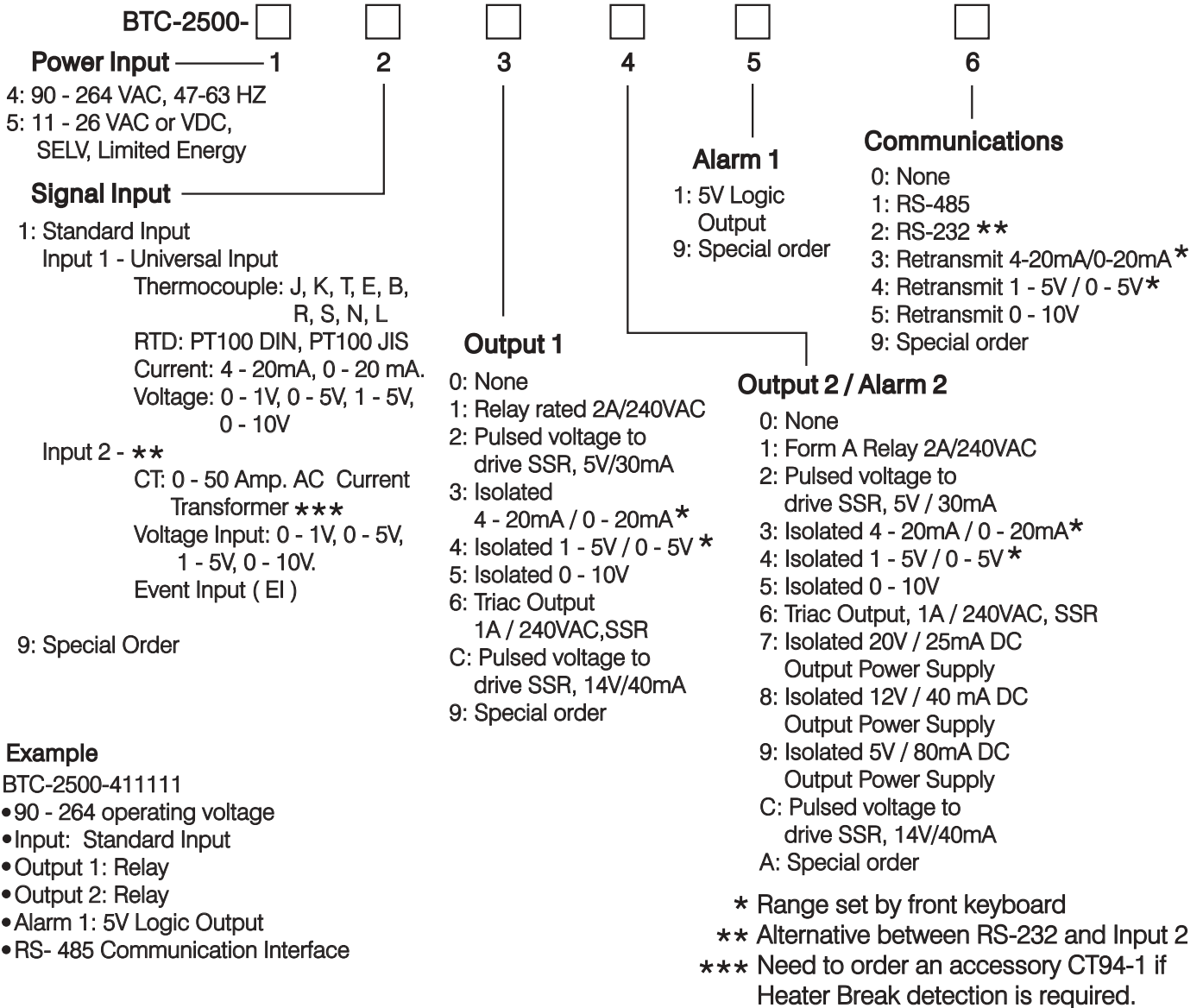

Figure 1.2 Fuzzy PID Enhances Control Stability

1-2 Ordering Code



Accessories

CT94-1 = 0 - 50 Amp. AC Current Transformer
OM95-3 = Isolated 4 - 20 mA / 0 - 20 mA Analog Output Module
OM95-4 = Isolated 1 - 5V / 0 - 5V Analog Output Module
OM95-5 = Isolated 0 - 10V Analog Output Module
OM94-6 = Isolated 1A / 240VAC Triac Output Module (SSR)
OM94-7 = 14V/40mA SSR Drive Module
DC94-1 = Isolated 20V / 25mA DC Output Power Supply
DC94-2 = Isolated 12V / 40mA DC Output Power Supply
DC94-3 = Isolated 5V / 80mA DC Output Power Supply
CM94-1 = Isolated RS-485 Interface Module
CM94-2 = Isolated RS-232 Interface Module
CM94-3 = Isolated 4 - 20 mA / 0 - 20 mA Retransmission Module
CM94-4 = Isolated 1 - 5V / 0 - 5V Retransmission Module
CM94-5 = Isolated 0 - 10V Retransmission Module
CC94-1 = RS-232 Interface Cable (2M)
CC91-3 = Programming Port Cable

Related Products

SNA10A = Smart Network Adaptor for Third Party Software, Converts 255 channels of RS-485 or RS-422 to RS-232 Network
SNA12A = Smart Network Adaptor for programming port to RS-232 interface
BC-Set = Configuration Software
Communicator = PC software to communicate 1024 tags

1-3 Programming Port and DIP Switch

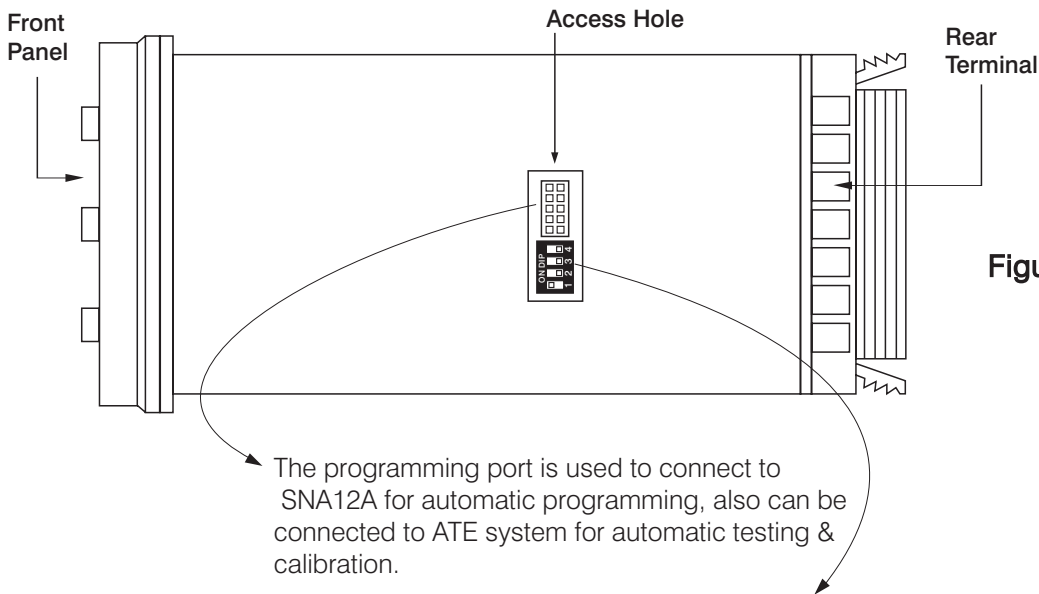

Figure 1.3 Access Hole Overview

		DIP Switch			
		1	2	3	4
Input 1 Select	TC, RTD, mV	■	□		
	0-1V, 0-5V, 1-5V, 0-10V	□	■		
	0-20 mA, 4-20 mA	■	■		
Lockout	All parameters are Unlocked			□	□
	Only SP1, SEL1-SEL5* are unlocked			■	□
	Only SP1 is unlocked			□	■
	All Parameters are locked			■	■
Factory Default Setting		■	□	□	□

Table 1.1 DIP Switch Configuration

The programming port is used for off-line automatic setup and testing procedures only. Don't attempt to make any connection to these pins when the unit is used for a normal control purpose.

When the unit leaves the factory, the DIP switch is set so that TC & RTD are selected for input 1 and all parameters are unlocked.

Lockout function is used to disable the adjustment of parameters as well as operation of calibration mode. However, the menu can still be viewed even under lockout condition.

* SEL1- SEL5 represent those parameters which are selected by using SEL1, SEL2,...SEL5 parameters contained in Setup menu. Parameters been selected are then allocated at the beginning of the user menu.

1-4 Keys and Displays

The unit is programmed by using three keys on the front panel. The available key functions are listed in following table.

Table 1.2 Keypad Operation

TOUCHKEYS	FUNCTION	DESCRIPTION
	Up Key	Press and release quickly to increase the value of parameter. Press and hold to accelerate increment speed.
	Down Key	Press and release quickly to decrease the value of parameter. Press and hold to accelerate decrement speed.
	Scroll Key	Select the parameter in a direct sequence.
Press for at least 3 seconds	Enter Key	Allow access to more parameters on user menu, also used to Enter manual mode, auto-tune mode, default setting mode and to save calibration data during calibration procedure.
Press for at least 6 seconds	Start Record Key	Reset historical values of PVHI and PVLO and start to record the peak process value.
Press	Reverse Scroll Key	Select the parameter in a reverse sequence during menu scrolling.
Press	Mode Key	Select the operation Mode in sequence.
Press	Reset Key	Reset the front panel display to a normal display mode, also used to leave the specific Mode execution to end up the auto-tune and manual control execution, and to quit the sleep mode.
Press for at least 3 seconds	Sleep Key	The controller enters the sleep mode if the sleep function (SLEP) is enabled (select YES).
Press	Factory Key	By entering correct security code to allow execution of engineering programs. This function is used only at the factory to manage the diagnostic reports. The user should never attempt to operate this function.

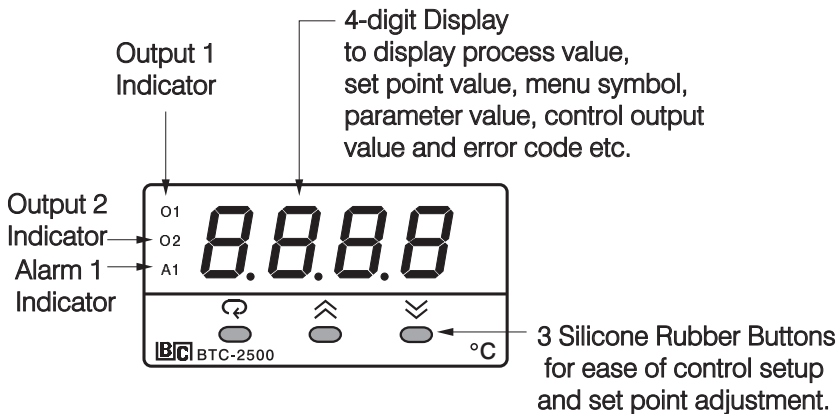

Figure 1.4 Front Panel Description

Table 1.3 Display Form of Characters

A	À	E	È	I	Ì	N	ñ	S	Š	X	
B	b	F	F	J	J	O	o	T	t	Y	Ÿ
C	Ĉ	G	G	K	Ķ	P	P	U	u	Z	
c	ċ	H	H	L	L	Q		V	Ū	?	?
D	d	h	h	M	ñ	R	r	W		=	=

► : Confused Character

How to display a 5-digit number ?

For a number with decimal point the display will be shifted one digit right:
 -199.99 will be displayed by -199.9
 4553.6 will be displayed by 4553

For a number without decimal point the display will be divided into two alternating phases:

-19999 will be displayed by:

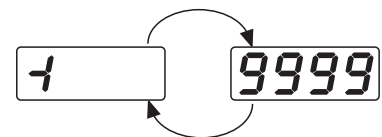

45536 will be displayed by:

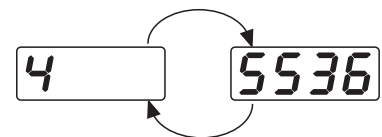

-9999 will be displayed by:

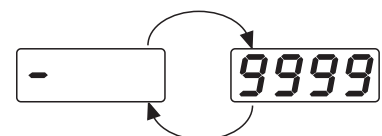

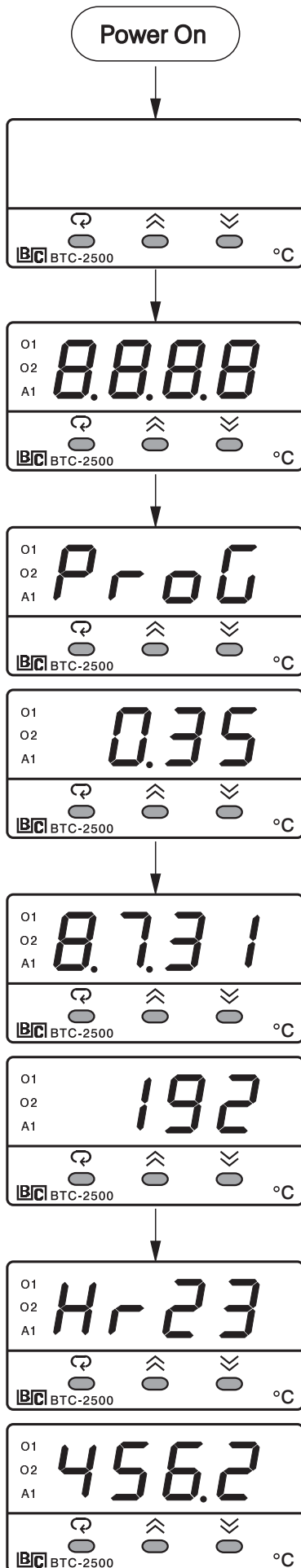

All segments of display and indicators are left off for 0.5 second.

All segments of display and indicators are lit for 2 seconds.

Display program code of the product for 2.5 seconds. Each display stays for 1.25 seconds

The left diagram shows program no. 0 (for BTC-2500) with version 35.

Display Date Code and Serial number for 2.5 seconds. Each display stays for 1.25 seconds

The left diagram shows Year 1998, Month July (7), Date 31'st and Serial number 192. This means that the product is the 192 'th unit produced on July 31'st, 1998. Note that the month code A stands for **October**, B stands for **November** and C stands for **December**.

Display the used hours for 2.5 seconds. The 6-digit number of hour is indicated by two successive displays and each one stays for 1.25 seconds.

The left diagram shows that the unit has been used for 23456.2 hours since production.

Figure 1.5 Display Sequence of Initial Message

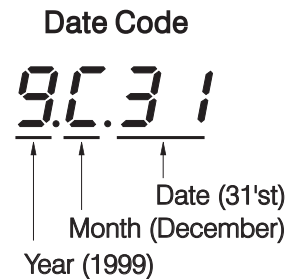

1-5 Menu Overview

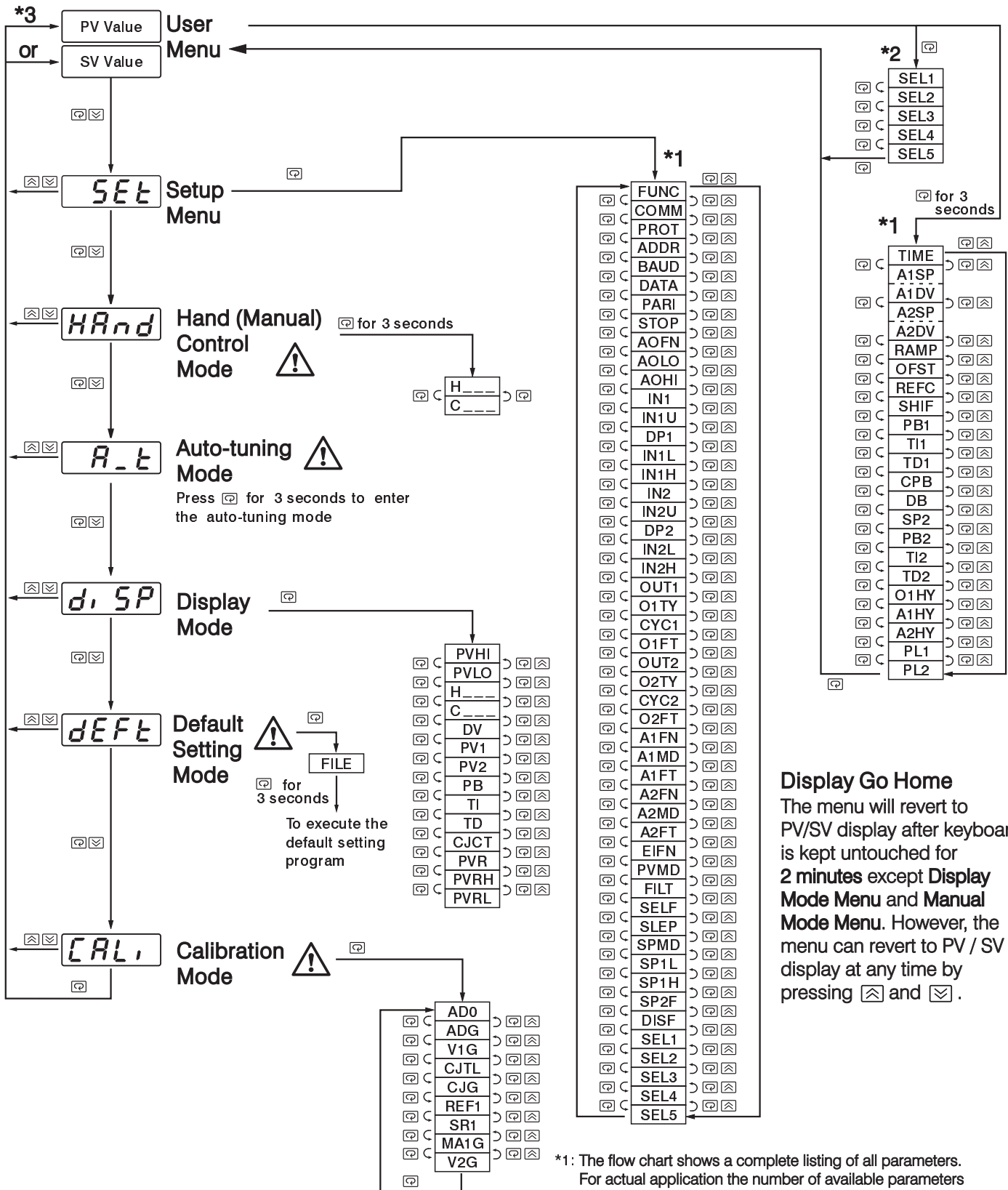

Display Go Home
The menu will revert to PV/SV display after keyboard is kept untouched for 2 minutes except Display Mode Menu and Manual Mode Menu. However, the menu can revert to PV / SV display at any time by pressing [Left] and [Right].

*1: The flow chart shows a complete listing of all parameters. For actual application the number of available parameters depends on setup conditions, and should be less than that shown in the flow chart. See Appendix A-1 for the existence conditions of each parameter.

*2: You can select at most 5 parameters put in front of the user menu by using SEL1 to SEL5 contained at the bottom of setup menu.

*3: Set DISF (display format) value in the setup menu to determine whether PV or SV is displayed.

! Apply these modes will break the control loop and change some of the previous setting data. Make sure that if the system is allowable to use these modes.

1-6 System Modes

The controller performs close loop control under its normal control mode condition. The controller will maintain its normal control mode when you are operating user menu, setup menu or display mode, reloading default values or applying event input signal. Under certain conditions the normal control mode will transfer to an **Exception Mode**. The exception modes include : **Sleep Mode, Manual Mode, Failure Mode, Calibration Mode** and **Auto-tuning Mode**. All these modes perform in an open loop control except the auto-tuning mode which performs ON-OFF plus PID close loop control. The mode transfer is governed by the priority conditions. A lower priority mode can not alter a higher priority mode, as shown in Figure 1.6.

- System Modes**
- Sleep Mode :**
See Section 4-11.
 - Manual Mode :**
See Section 3-23.
 - Failure Mode :**
See Section 3-17.
 - Calibration Mode :**
See Chapter 6.
 - Auto-tuning Mode :**
See Section 3-20.
 - Normal Control Mode :**
See Section 3-24, 3-26, 4-1

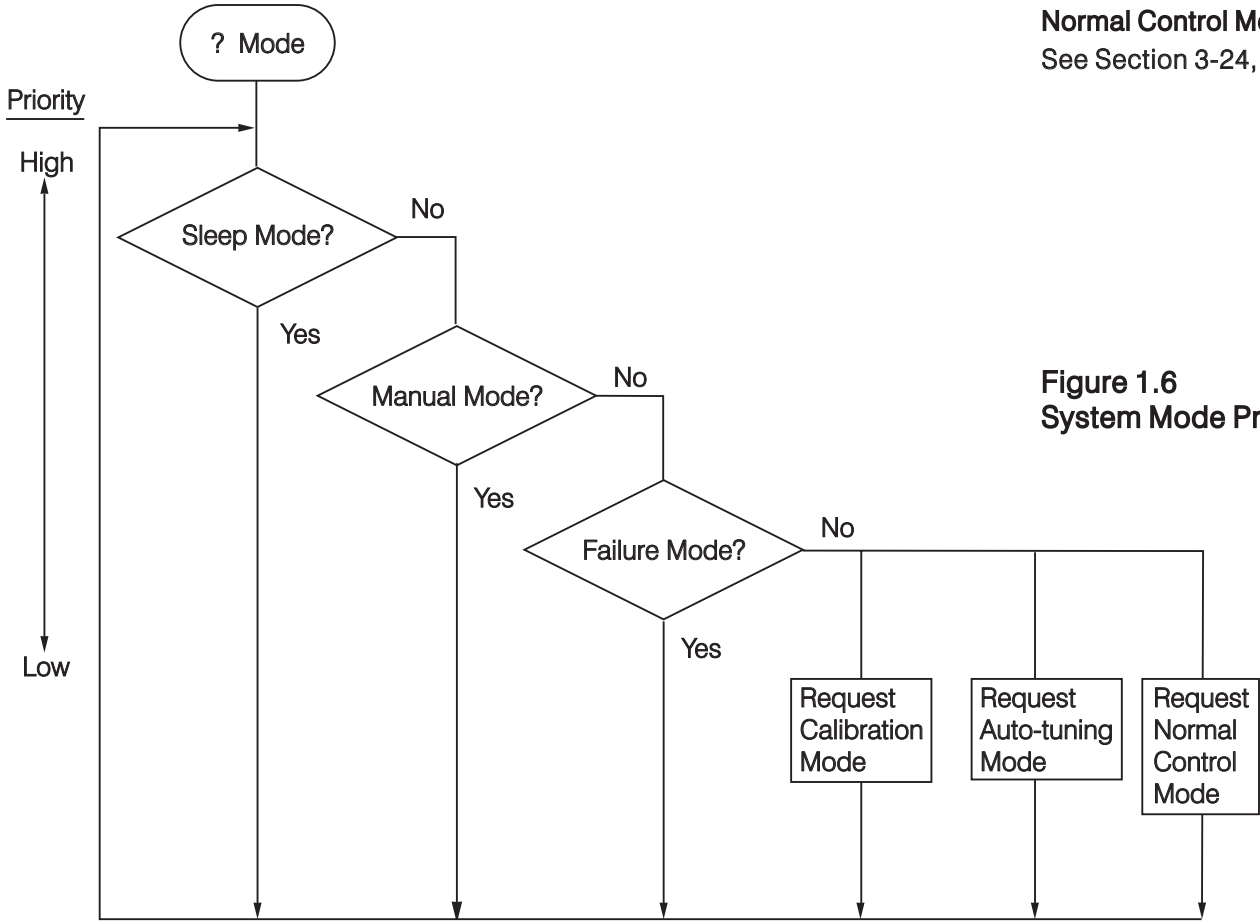

Figure 1.6 System Mode Priority

The calibration mode, auto-tuning mode and normal control mode are in the same priority level. The sleep mode is in the highest priority.

1-7 Parameter Description

Table 1.4 Parameter Description

Contained in	Basic Function	Parameter Notation	Display Format	Parameter Description	Range	Default Value
User Menu	✓	SP1		Set point 1	Low: SP1L High: SP1H	100.0°C (212.0°F)
	✓	TIME	<i>t, nE</i>	Dwell Time	Low: 0 High: 6553.5 minutes	0.0
	✓	A1SP	<i>A1SP</i>	Alarm 1 Set point	See Table 1.5, 1.6	100.0°C (212.0°F)
	✓	A1DV	<i>A1dV</i>	Alarm 1 Deviation Value	Low: -200.0°C (-360.0°F) High: 200.0°C (360.0°F)	10.0°C (18.0°F)
	✓	A2SP	<i>A2SP</i>	Alarm 2 Set point	See Table 1.5, 1.7	100.0°C (212.0°F)
	✓	A2DV	<i>A2dV</i>	Alarm 2 Deviation Value	Low: -200.0°C (-360.0°F) High: 200.0°C (360.0°F)	10.0°C (18.0°F)
		RAMP	<i>rAnP</i>	Ramp Rate	Low: 0 High: 500.0°C (900.0°F)	0.0
	✓	OFST	<i>oFSt</i>	Offset Value for P control	Low: 0 High: 100.0 %	25.0
		REFC	<i>rEFc</i>	Reference Constant for Specific Function	Low: 0 High: 60	2
	✓	SHIF	<i>SH, F</i>	PV1 Shift (offset) Value	Low: -200.0°C (-360.0°F) High: 200.0°C (360.0°F)	0.0
	✓	PB1	<i>Pb1</i>	Proportional Band 1 Value	Low: 0 High: 500.0°C (900.0°F)	10.0°C (18.0°F)
	✓	TI1	<i>t, 1</i>	Integral Time 1 Value	Low: 0 High: 1000 sec	100
	✓	TD1	<i>t, d1</i>	Derivative Time 1 Value	Low: 0 High: 360.0 sec	25.0
	✓	CPB	<i>Cpb</i>	Cooling Proportional Band Value	Low: 1 High: 255 %	100
	✓	DB	<i>db</i>	Heating-Cooling Dead Band Negative Value= Overlap	Low: -36.0 High: 36.0 %	0
		SP2	<i>SP2</i>	Set point 2	See Table 1.5, 1.8	37.8°C (100.0°F)
		PB2	<i>Pb2</i>	Proportional Band 2 Value	Low: 0 High: 500.0°C (900.0°F)	10.0°C (18.0°F)
		TI2	<i>t, 2</i>	Integral Time 2 Value	Low: 0 High: 1000 sec	100
		TD2	<i>t, d2</i>	Derivative Time 2 Value	Low: 0 High: 360.0 sec	25.0
	✓	O1HY	<i>o1HY</i>	Output 1 ON-OFF Control Hysteresis	Low: 0.1 High: 55.6°C (100.0°F)	0.1
	✓	A1HY	<i>A1HY</i>	Hysteresis Control of Alarm 1	Low: 0.1 High: 10.0°C (18.0°F)	0.1
	✓	A2HY	<i>A2HY</i>	Hysteresis Control of Alarm 2	Low: 0.1 High: 10.0°C (18.0°F)	0.1
		PL1	<i>PL1</i>	Output 1 Power Limit	Low: 0 High: 100 %	100
		PL2	<i>PL2</i>	Output 2 Power Limit	Low: 0 High: 100 %	100
Setup Menu	✓	FUNC	<i>Func</i>	Function Complexity Level	0 <i>basic</i> : Basic Function Mode 1 <i>Full</i> : Full Function Mode	1
		COMM	<i>Comm</i>	Communication Interface Type	0 <i>none</i> : No communication function 1 <i>485</i> : RS-485 interface 2 <i>232</i> : RS-232 interface 3 <i>4-20</i> : 4 - 20 mA analog retransmission output 4 <i>0-20</i> : 0 - 20 mA analog retransmission output 5 <i>0-1V</i> : 0 - 1V analog retransmission output 6 <i>0-5V</i> : 0 - 5V analog retransmission output 7 <i>1-5V</i> : 1 - 5V analog retransmission output 8 <i>0-10</i> : 0 - 10V analog retransmission output	1
		PROT	<i>Prot</i>	COMM Protocol Selection	0 <i>rtu</i> : Modbus protocol RTU mode	0

Table 1.4 Parameter Description (continued 2/7)

Contained in	Basic Function	Parameter Notation	Display Format	Parameter Description	Range	Default Value
Setup Menu		ADDR	<i>Addr</i>	Address Assignment of Digital COMM	Low: 1 High: 255	—
		BAUD	<i>bAud</i>	Baud Rate of Digital COMM	0 0.3 : 0.3 Kbits/s baud rate 1 0.6 : 0.6 Kbits/s baud rate 2 1.2 : 1.2 Kbits/s baud rate 3 2.4 : 2.4 Kbits/s baud rate 4 4.8 : 4.8 Kbits/s baud rate 5 9.6 : 9.6 Kbits/s baud rate 6 14.4 : 14.4 Kbits/s baud rate 7 19.2 : 19.2 Kbits/s baud rate 8 28.8 : 28.8 Kbits/s baud rate 9 38.4 : 38.4 Kbits/s baud rate	5
		DATA	<i>dAtA</i>	Data Bit count of Digital COMM	0 7b, t : 7 data bits 1 8b, t : 8 data bits	1
		PARI	<i>pAr, t</i>	Parity Bit of Digital COMM	0 EVEN : Even parity 1 odd : Odd parity 2 nonE : No parity bit	0
		STOP	<i>StoP</i>	Stop Bit Count of Digital COMM	0 1b, t : One stop bit 1 2b, t : Two stop bits	0
		AOFN	<i>RoFn</i>	Analog Output Function	0 PV1 : Retransmit IN1 process value 1 PV2 : Retransmit IN2 process value 2 P1-2 : Retransmit IN1-IN2 difference process value 3 P2-1 : Retransmit IN2-IN1 difference process value 4 SV : Retransmit set point value 5 nV1 : Retransmit output 1 manipulation value 6 nV2 : Retransmit output 2 manipulation value 7 dV : Retransmit deviation(PV-SV) Value	0
		AOLO	<i>RoLo</i>	Analog Output Low Scale Value	Low: -19999 High: 45536	0°C (32.0°F)
		AOHI	<i>RoHi</i>	Analog Output High Scale Value	Low: -19999 High: 45536	100.0°C (212.0°F)
	✓	IN1	<i>in1</i>	IN1 Sensor Type Selection	0 J-tC : J type thermocouple 1 K-tC : K type thermocouple 2 T-tC : T type thermocouple 3 E-tC : E type thermocouple 4 B-tC : B type thermocouple 5 R-tC : R type thermocouple 6 S-tC : S type thermocouple	1 (0)

Table 1.4 Parameter Description (continued 3/7)

Contained in	Basic Function	Parameter Notation	Display Format	Parameter Description	Range	Default Value	
Setup Menu	✓	IN1	<i>in1</i>	IN1 Sensor Type Selection	7 <i>n-tC</i> : N type thermocouple 8 <i>L-tC</i> : L type thermocouple 9 <i>Pt.dn</i> : PT 100 ohms DIN curve 10 <i>Pt.JS</i> : PT 100 ohms JIS curve 11 <i>4-20</i> : 4 - 20 mA linear current input 12 <i>0-20</i> : 0 - 20 mA linear current input 13 <i>0-1V</i> : 0 - 1V linear Voltage input 14 <i>0-5V</i> : 0 - 5V linear Voltage input 15 <i>1-5V</i> : 1 - 5V linear Voltage input 16 <i>0-10</i> : 0 - 10V linear Voltage input 17 <i>SPEC</i> : Special defined sensor curve	1 (0)	
	✓	IN1U	<i>in1u</i>	IN1 Unit Selection	0 <i>oC</i> : Degree C unit 1 <i>oF</i> : Degree F unit 2 <i>Pu</i> : Process unit	0 (1)	
	✓	DP1	<i>dp1</i>	IN1 Decimal Point Selection	0 <i>nodp</i> : No decimal point 1 <i>1-dp</i> : 1 decimal digit 2 <i>2-dp</i> : 2 decimal digits 3 <i>3-dp</i> : 3 decimal digits	1	
	✓	IN1L	<i>in1L</i>	IN1 Low Scale Value	Low: -19999 High: 45536	0	
	✓	IN1H	<i>in1H</i>	IN1 High Scale Value	Low: -19999 High: 45536	1000	
			IN2	<i>in2</i>	IN2 Signal Type Selection	0 <i>nonE</i> : IN2 no function 1 <i>Ct</i> : Current transformer input 4 <i>0-1V</i> : 0 - 1V linear voltage input 5 <i>0-5V</i> : 0 - 5V linear voltage input 6 <i>1-5V</i> : 1 - 5V linear voltage input 7 <i>0-10</i> : 0 - 10V linear voltage input 20 <i>E.Fn</i> : Perform Event input function	1
			IN2U	<i>in2u</i>	IN2 Unit Selection	Same as IN1U	2
			DP2	<i>dp2</i>	IN2 Decimal Point Selection	Same as DP1	1
			IN2L	<i>in2L</i>	IN2 Low Scale Value	Low: -19999 High: 45536	0
			IN2H	<i>in2H</i>	IN2 High Scale Value	Low: -19999 High: 45536	1000
	✓	OUT1	<i>out1</i>	Output 1 Function	0 <i>reYr</i> : Reverse (heating) control action 1 <i>dirE</i> : Direct (cooling) control action	0	
	✓	O1TY	<i>o1ty</i>	Output 1 Signal Type	0 <i>reLY</i> : Relay output 1 <i>SSrd</i> : Solid state relay drive output 2 <i>SSr</i> : Solid state relay output 3 <i>4-20</i> : 4 - 20 mA current module	0	

Table 1.4 Parameter Description (continued 4/7)

Contained in	Basic Function	Parameter Notation	Display Format	Parameter Description	Range	Default Value
Setup Menu	✓	O1TY	<i>o 1ty</i>	Output 1 Signal Type	4 <i>0-20</i> : 0 - 20 mA current module 5 <i>0-1V</i> : 0 - 1V voltage module 6 <i>0-5V</i> : 0 - 5V voltage module 7 <i>1-5V</i> : 1 - 5V voltage module 8 <i>0-10</i> : 0 - 10V voltage module	0
	✓	CYC1	<i>[CYC 1]</i>	Output 1 Cycle Time	Low: 0.1 High: 100.0 sec	18.0
	✓	O1FT	<i>o 1ft</i>	Output 1 Failure Transfer Mode	Select BPLS (bumpless transfer) or 0.0 ~ 100.0 % to continue output 1 control function as the unit fails, power starts or manual mode starts.	BPLS
	✓	OUT2	<i>out 2</i>	Output 2 Function	0 <i>nonE</i> : Output 2 no function 1 <i>COOL</i> : PID cooling control 2 <i>-AL2</i> : Perform alarm 2 function 3 <i>dCPS</i> : DC power supply module installed	0
	✓	O2TY	<i>o 2ty</i>	Output 2 Signal Type	Same as O1TY	0
	✓	CYC2	<i>[CYC 2]</i>	Output 2 Cycle Time	Low: 0.1 High: 100.0 sec	18.0
	✓	O2FT	<i>o 2ft</i>	Output 2 Failure Transfer Mode	Select BPLS (bumpless transfer) or 0.0 ~ 100.0 % to continue output 2 control function as the unit fails, power starts or manual mode starts.	BPLS
	✓	A1FN	<i>A 1Fn</i>	Alarm 1 Function	0 <i>nonE</i> : No alarm function 1 <i>t, nr</i> : Dwell timer action 2 <i>dEH,</i> : Deviation high alarm 3 <i>dELo</i> : Deviation low alarm 4 <i>dbH,</i> : Deviation band out of band alarm 5 <i>dbLo</i> : Deviation band in band alarm 6 <i>PY 1H</i> : IN1 process value high alarm 7 <i>PY 1L</i> : IN1 process value low alarm 8 <i>PY 2H</i> : IN2 process value high alarm 9 <i>PY 2L</i> : IN2 process value low alarm 10 <i>P 12H</i> : IN1 or IN2 process value high alarm 11 <i>P 12L</i> : IN1 or IN2 process value low alarm 12 <i>d 12H</i> : IN1-IN2 difference process value high alarm 13 <i>d 12L</i> : IN1-IN2 difference process value low alarm 14 <i>Lb</i> : Loop break alarm 15 <i>SEnb</i> : Sensor break or A-D fails	2
	✓	A1MD	<i>A 1nd</i>	Alarm 1 Operation Mode	0 <i>nor n̄</i> : Normal alarm action 1 <i>Ltch</i> : Latching alarm action 2 <i>HoLd</i> : Hold alarm action 3 <i>LtHo</i> : Latching & Hold action	0

Table 1.4 Parameter Description (continued 5/7)

Contained in	Basic Function	Parameter Notation	Display Format	Parameter Description	Range	Default Value
Setup Menu	✓	A1FT	<i>A1Ft</i>	Alarm 1 Failure Transfer Mode	0 <i>off</i> : Alarm output OFF as unit fails 1 <i>on</i> : Alarm output ON as unit fails	1
	✓	A2FN	<i>A2Fn</i>	Alarm 2 Function	Same as A1FN	2
	✓	A2MD	<i>A2Md</i>	Alarm 2 Operation Mode	Same as A1MD	0
	✓	A2FT	<i>A2Ft</i>	Alarm 2 Failure Transfer Mode	Same as A1FT	1
		EIFN	<i>EiFn</i>	Event Input Function	0 <i>none</i> : Event input no function 1 <i>SP2</i> : SP2 activated to replace SP1 2 <i>P1d2</i> : PB2, TI2, TD2 activated to replace PB1, TI1, TD1 3 <i>SPP2</i> : SP2, PB2, TI2, TD2 activated to replace SP1, PB1, TI1, TD1 4 <i>rSA1</i> : Reset alarm 1 output 5 <i>rSA2</i> : Reset alarm 2 output 6 <i>rA12</i> : Reset alarm 1 & alarm 2 7 <i>do1</i> : Disable Output 1 8 <i>do2</i> : Disable Output 2 9 <i>do12</i> : Disable Output 1 & Output 2 10 <i>Lock</i> : Lock All Parameters	1
		PVMD	<i>PVnd</i>	PV Mode Selection	0 <i>PV1</i> : Use PV1 as process value 1 <i>PV2</i> : Use PV2 as process value 2 <i>P1-2</i> : Use PV1 – PV2 (difference) as process value 3 <i>P2-1</i> : Use PV2 – PV1 (difference) as process value	0
		FILT	<i>Filt</i>	Filter Damping Time Constant of PV	0 <i>0</i> : 0 second time constant 1 <i>0.2</i> : 0.2 second time constant 2 <i>0.5</i> : 0.5 second time constant 3 <i>1</i> : 1 second time constant 4 <i>2</i> : 2 seconds time constant 5 <i>5</i> : 5 seconds time constant 6 <i>10</i> : 10 seconds time constant 7 <i>20</i> : 20 seconds time constant 8 <i>30</i> : 30 seconds time constant 9 <i>60</i> : 60 seconds time constant	2
	✓	SELF	<i>SELF</i>	Self Tuning Function Selection	0 <i>none</i> : Self tune function disabled 1 <i>YES</i> : Self tune function enabled	0
		SLEP	<i>SLEP</i>	Sleep mode Function Selection	0 <i>none</i> : Sleep mode function disabled 1 <i>YES</i> : Sleep mode function enabled	0

Table 1.4 Parameter Description (continued 6/7)

Contained in	Basic Function	Parameter Notation	Display Format	Parameter Description	Range	Default Value	
Setup Menu		SPMD	<i>SP.MD</i>	Set point Mode Selection	0 <i>SP12</i> : Use SP1 or SP2 (depends on EIFN) as set point 1 <i>MINR</i> : Use minute ramp rate as set point 2 <i>HRR</i> : Use hour ramp rate as set point 3 <i>PV1</i> : Use IN1 process value as set point 4 <i>PV2</i> : Use IN2 process value as set point 5 <i>PUMP</i> : Selected for pump control	0	
	✓	SP1L	<i>SP1L</i>	SP1 Low Scale Value	Low: -19999 High: 45536	0 °C (32.0 °F)	
	✓	SP1H	<i>SP1H</i>	SP1 High Scale Value	Low: -19999 High: 45536	1000.0 °C (1832.0 °F)	
		SP2F	<i>SP2F</i>	Format of set point 2 Value	0 <i>ACTU</i> : set point 2 (SP2) is an actual value 1 <i>DEVI</i> : set point 2 (SP2) is a deviation value	0	
	✓	DISF	<i>DISF</i>	Display Format	0 <i>PV</i> : Display PV value 1 <i>SV</i> : Display SV value		
	✓	SEL1	<i>SEL1</i>	Select 1'st Parameter	0 <i>none</i> : No parameter put ahead 1 <i>TIME</i> : Parameter TIME put ahead 2 <i>A1SP</i> : Parameter A1SP put ahead 3 <i>A1DV</i> : Parameter A1DV put ahead 4 <i>A2SP</i> : Parameter A2SP put ahead 5 <i>A2DV</i> : Parameter A2DV put ahead 6 <i>RAMP</i> : Parameter RAMP put ahead 7 <i>OFST</i> : Parameter OFST put ahead 8 <i>REFC</i> : Parameter REFC put ahead 9 <i>SHIF</i> : Parameter SHIF put ahead 10 <i>PB1</i> : Parameter PB1 put ahead 11 <i>TI1</i> : Parameter TI1 put ahead 12 <i>TD1</i> : Parameter TD1 put ahead 13 <i>CPB</i> : Parameter CPB put ahead 14 <i>DB</i> : Parameter DB put ahead 15 <i>SP2</i> : Parameter SP2 put ahead 16 <i>PB2</i> : Parameter PB2 put ahead 17 <i>TI2</i> : Parameter TI2 put ahead 18 <i>TD2</i> : Parameter TD2 put ahead	0	
	✓	SEL2	<i>SEL2</i>	Select 2'nd Parameter	Same as SEL1	0	
	✓	SEL3	<i>SEL3</i>	Select 3'rd Parameter	Same as SEL1	0	
	✓	SEL4	<i>SEL4</i>	Select 4'th Parameter	Same as SEL1	0	
	✓	SEL5	<i>SEL5</i>	Select 5'th Parameter	Same as SEL1	0	
	Calibration Mode Menu	✓	AD0	<i>AD0</i>	A to D Zero Calibration Coefficient	Low: -360 High: 360	—
		✓	ADG	<i>ADG</i>	A to D Gain Calibration Coefficient	Low: -199.9 High: 199.9	—
		✓	V1G	<i>V1G</i>	Voltage Input 1 Gain Calibration Coefficient	Low: -199.9 High: 199.9	—
✓		CJTL	<i>CJTL</i>	Cold Junction Low Temperature Calibration Coefficient	Low: -5.00 °C High: 40.00 °C	—	

Table 1.4 Parameter Description (continued 7/7)

Contained in	Basic Function	Parameter Notation	Display Format	Parameter Description	Range		Default Value
Calibration Mode Menu	✓	CJG	<i>CJG</i>	Cold Junction Gain Calibration Coefficient	Low: -199.9	High: 199.9	—
	✓	REF1	<i>REF.1</i>	Reference Voltage 1 Calibration Coefficient for RTD 1	Low: -199.9	High: 199.9	—
	✓	SR1	<i>SR.1</i>	Serial Resistance 1 Calibration Coefficient for RTD 1	Low: -199.9	High: 199.9	—
	✓	MA1G	<i>mA 1G</i>	mA Input 1 Gain Calibration Coefficient	Low: -199.9	High: 199.9	—
	✓	V2G	<i>V2G</i>	Voltage Input 2 Gain Calibration Coefficient	Low: -199.9	High: 199.9	—
Display Mode Menu	✓	PVHI	<i>PVHI</i>	Historical Maximum Value of PV	Low: -19999	High: 45536	—
	✓	PVLO	<i>PVLO</i>	Historical Minimum Value of PV	Low: -19999	High: 45536	—
	✓	MV1	<i>H---</i>	Current Output 1 Value	Low: 0	High: 100.00 %	—
	✓	MV2	<i>[----</i>	Current Output 2 Value	Low: 0	High: 100.00 %	—
	✓	DV	<i>dV</i>	Current Deviation (PV-SV) Value	Low: -12600	High: 12600	—
	✓	PV1	<i>PV1</i>	IN1 Process Value	Low: -19999	High: 45536	—
	✓	PV2	<i>PV2</i>	IN2 Process Value	Low: -19999	High: 45536	—
	✓	PB	<i>Pb</i>	Current Proportional Band Value	Low: 0	High: 500.0 °C (900.0 °F)	—
	✓	TI	<i>t_i</i>	Current Integral Time Value	Low: 0	High: 4000 sec	—
	✓	TD	<i>t_d</i>	Current Derivative Time Value	Low: 0	High: 1440 sec	—
	✓	CJCT	<i>CJCT</i>	Cold Junction Compensation Temperature	Low: -40.00 °C	High: 90.00 °C	—
	✓	PVR	<i>PVr</i>	Current Process Rate Value	Low: -16383	High: 16383	—
	✓	PVRH	<i>PVr.H</i>	Maximum Process Rate Value	Low: -16383	High: 16383	—
	✓	PVRL	<i>PVr.L</i>	Minimum Process Rate Value	Low: -16383	High: 16383	—

Input Type	J_TC	K_TC	T_TC	E_TC	B_TC	R_TC	S_TC
Range Low	-120 °C (-184 °F)	-200 °C (-328 °F)	-250 °C (-418 °F)	-100 °C (-148 °F)	0 °C (32 °F)	0 °C (32 °F)	0 °C (32 °F)
Range High	1000 °C (1832 °F)	1370 °C (2498 °F)	400 °C (752 °F)	900 °C (1652 °F)	1820 °C (3308 °F)	1767.8 °C (3214 °F)	1767.8 °C (3214 °F)

Table 1.5 Input (IN1 or IN2) Range

Input Type	N_TC	L_TC	PT.DN	PT.JS	CT	Linear (V, mA) or SPEC
Range Low	-250 °C (-418 °F)	-200 °C (-328 °F)	-210 °C (-346 °F)	-200 °C (-328 °F)	0 Amp	-19999
Range High	1300 °C (2372 °F)	900 °C (1652 °F)	700 °C (1292 °F)	600 °C (1112 °F)	90 Amp	45536

Range of A1SP same as range of	If A1FN =	PV1.H, PV1.L	PV2.H,PV2.L	P1.2.H, P1.2.L D1.2.H, D1.2.L
		IN1	IN2	IN1, IN2

Table 1.6 Range Determination for A1SP

Range of A2SP same as range of	If A2FN =	PV1.H, PV1.L	PV2.H,PV2.L	P1.2.H, P1.2.L D1.2.H, D1.2.L
		IN1	IN2	IN1, IN2

Table 1.7 Range Determination for A2SP

Range of SP2 same as range of	If PVMD =	PV1	PV2	P1-2, P2-1
		IN1	IN2	IN1, IN2

Table 1.8 Range Determination for SP2

Exception: If any of A1SP, A2SP or SP2 is configured with respect to CT input, its adjustment range is unlimited.

Chapter 2 Installation

! Dangerous voltages capable of causing death are sometimes present in this instrument. Before installation or beginning any troubleshooting procedures the power to all equipment must be switched off and isolated. Units suspected of being faulty must be disconnected and removed to a properly equipped workshop for testing and repair. Component replacement and internal adjustments must be made by a qualified maintenance person only.

! To minimize the possibility of fire or shock hazards, do not expose this instrument to rain or excessive moisture.

! Do not use this instrument in areas under hazardous conditions such as excessive shock, vibration, dirt, moisture, corrosive gases or oil. The ambient temperature of the areas should not exceed the maximum rating specified in Chapter 8.

2-1 Unpacking

Upon receipt of the shipment remove the unit from the carton and inspect the unit for shipping damage. If any damage due to transit, report and claim with the carrier. Write down the model number, serial number, and date code for future reference when corresponding with our service center. The serial number (S/N) and date code (D/C) are labeled on the box and the housing of control.

2-2 Mounting

Make panel cutout to dimension shown in Figure 2.1.

Take both mounting clamps away and insert the controller into panel cutout. Install the mounting clamps back. Gently tighten the screws in the clamp till the controller front panels is fitted snugly in the cutout.

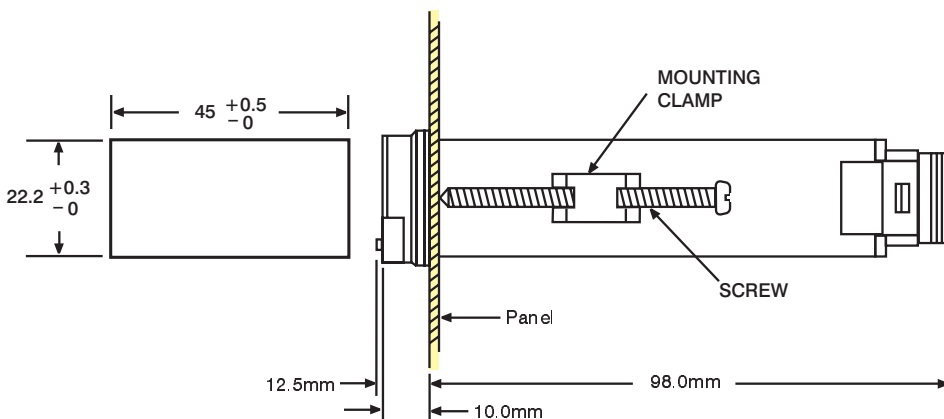

Figure 2.1
Mounting Dimensions

2-3 Wiring Precautions

- * Before wiring, verify the label for correct model number and options. Switch off the power while checking.
- * Care must be taken to ensure that maximum voltage rating specified on the label are not exceeded.
- * It is recommended that power of these units to be protected by fuses or circuit breakers rated at the minimum value possible.
- * All units should be installed inside a suitably grounded metal enclosure to prevent live parts being accessible from human hands and metal tools.
- * All wiring must conform to appropriate standards of good practice and local codes and regulations. Wiring must be suitable for voltage, current, and temperature rating of the system.
- * The "stripped" leads as specified in Figure 2.2 below are used for power and sensor connections.
- * Beware not to over-tighten the terminal screws.
- * Unused control terminals should not be used as jumper points as they may be internally connected, causing damage to the unit.
- * Verify that the ratings of the output devices and the inputs as specified in Chapter 8 are not exceeded.
- * Electric power in industrial environments contains a certain amount of noise in the form of transient voltage and spikes. This electrical noise can enter and adversely affect the operation of microprocessor-based controls. For this reason we strongly recommend the use of shielded thermocouple extension wire which connects the sensor to the controller. This wire is a twisted-pair construction with foil wrap and drain wire. The drain wire is to be attached to ground at one end only.

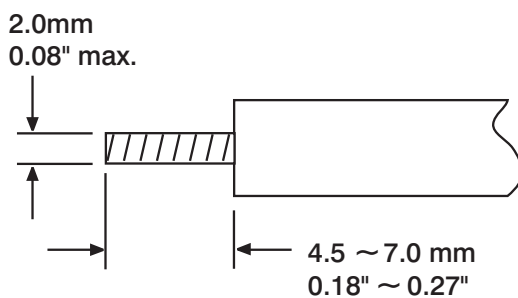

Figure 2.2 Lead Termination

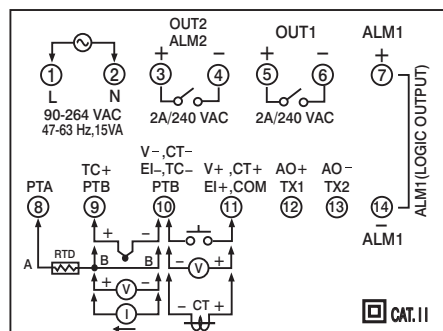

Figure 2.3 Rear Terminal Connection Diagram

2-4 Power Wiring

The controller is supplied to operate at 11-26 VAC / VDC or 90-264VAC. Check that the installation voltage corresponds with the power rating indicated on the product label before connecting power to the controller.

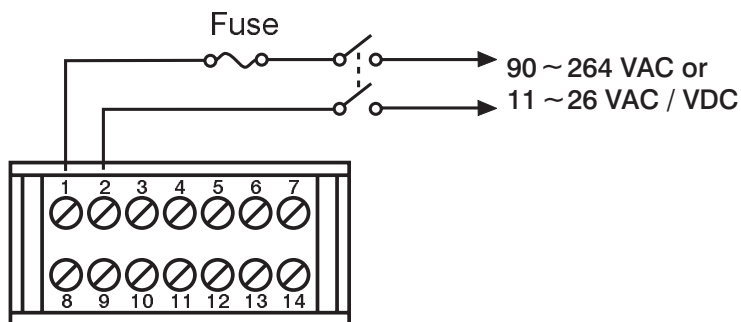



Figure 2.4
Power Supply Connections

 This equipment is designed for installation in an enclosure which provides adequate protection against electric shock. The enclosure must be connected to earth ground.

Local requirements regarding electrical installation should be rigidly observed. Consideration should be given to prevent from unauthorized person access to the power terminals.

2-5 Sensor Installation Guidelines

Proper sensor installation can eliminate many problems in a control system. The probe should be placed so that it can detect any temperature change with minimal thermal lag. In a process that requires fairly constant heat output, the probe should be placed closed to the heater. In a process where the heat demand is variable, the probe should be closed to the work area. Some experiments with probe location are often required to find this optimum position.

In a liquid process, addition of a stirrer will help to eliminate thermal lag. Since the thermocouple is basically a point measuring device, placing more than one thermocouple in parallel can provide an average temperature readout and produce better results in most air heated processes.

Proper sensor type is also a very important factor to obtain precise measurements. The sensor must have the correct temperature range to meet the process requirements. In special processes the sensor might need to have different requirements such as leak-proof, anti-vibration, antiseptic, etc.

Standard sensor limits of error are ± 4 degrees F (± 2 degrees C) or 0.75% of sensed temperature (half that for special) plus drift caused by improper protection or an over-temperature occurrence. This error is far greater than controller error and cannot be corrected on the sensor except by proper selection and replacement.

2-6 Thermocouple Input Wiring

Thermocouple input connections are shown in Figure 2.5. The correct type of thermocouple extension lead-wire or compensating cable must be used for the entire distance between the controller and the thermocouple, ensuring that the correct polarity is observed throughout. Joints in the cable should be avoided, if possible.

If the length of thermocouple plus the extension wire is too long, it may affect the temperature measurement. A 400 ohms K type or a 500 ohms J type thermocouple lead resistance will produce 1 degree C temperature error approximately.

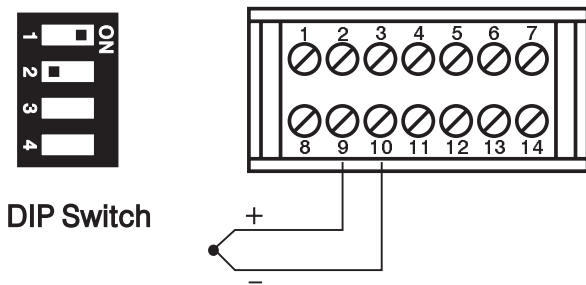

Figure 2.5
Thermocouple Input Wiring

The colour codes used on the thermocouple extension leads are shown in Table 2.1.

Table 2.1 Thermocouple Cable Colour Codes

Thermocouple Type	Cable Material	British BS	American ASTM	German DIN	French NFE
T	Copper (Cu) Constantan (Cu-Ni)	+ white - blue * blue	+ blue - red * blue	+ red - brown * brown	+ yellow - blue * blue
J	Iron (Fe) Constantan (Cu- Ni)	+ yellow - blue * black	+ white - red * black	+ red - blue * blue	+ yellow - black * black
K	Nickel-Chromium (Ni-Cr) Nickel-Aluminum (Ni-Al)	+ brown - blue * red	+ yellow - red * yellow	+ red - green * green	+ yellow - purple * yellow
R S	Pt-13%Rh,Pt Pt-10%Rh,Pt	+ white - blue * green	+ black - red * green	+ red - white * white	+ yellow - green * green
B	Pt-30%Rh Pt-6%Rh	Use Copper Wire	+grey - red * grey	+red -grey * grey	Use Copper Wire

* Colour of overall sheath

2-7 RTD Input Wiring

RTD connection are shown in Figure 2.6, with the compensating lead connected to terminal 9. For two-wire RTD inputs, terminals 9 and 10 should be linked. The three-wire RTD offers the capability of lead resistance compensation provided that the three leads should be of same gauge and equal length.

Two-wire RTD should be avoided, if possible, for the purpose of accuracy. A 0.4 ohm lead resistance of a two-wire RTD will produce 1 degree C temperature error.

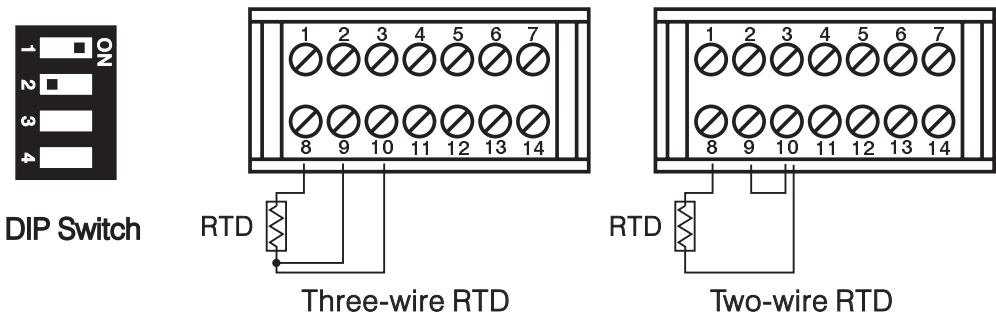

Figure 2.6
RTD Input Wiring

2-8 Linear DC Input Wiring

DC linear voltage and linear current connections for input 1 are shown in Figure 2.7 and Figure 2.8 .

DC linear voltage and linear current connections for input 2 are shown in Figure 2.9 and Figure 2.10 .

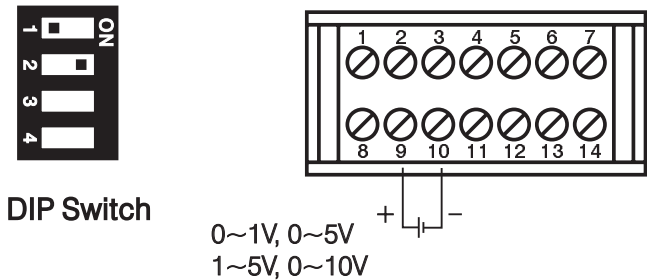

Figure 2.7
Input 1 Linear Voltage Wiring

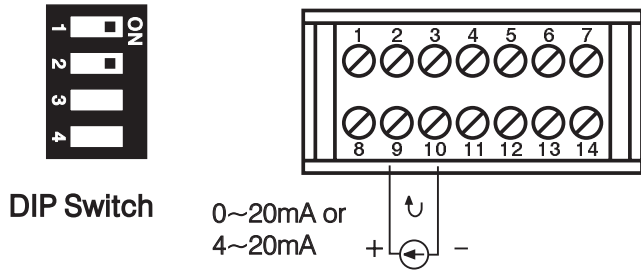

Figure 2.8
Input 1 Linear Current Wiring

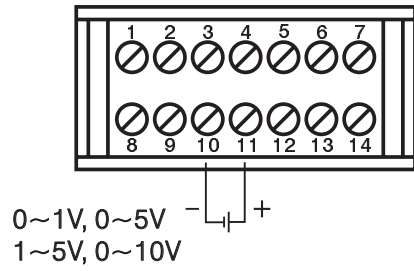

Figure 2.9
Input 2 Linear Voltage Wiring

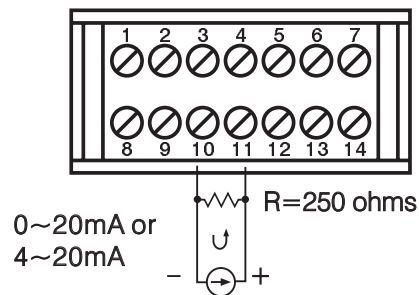

Figure 2.10
Input 2 Linear Current Wiring

IN2= 0-5V or 1-5V

2-9 CT / Heater Current Input Wiring

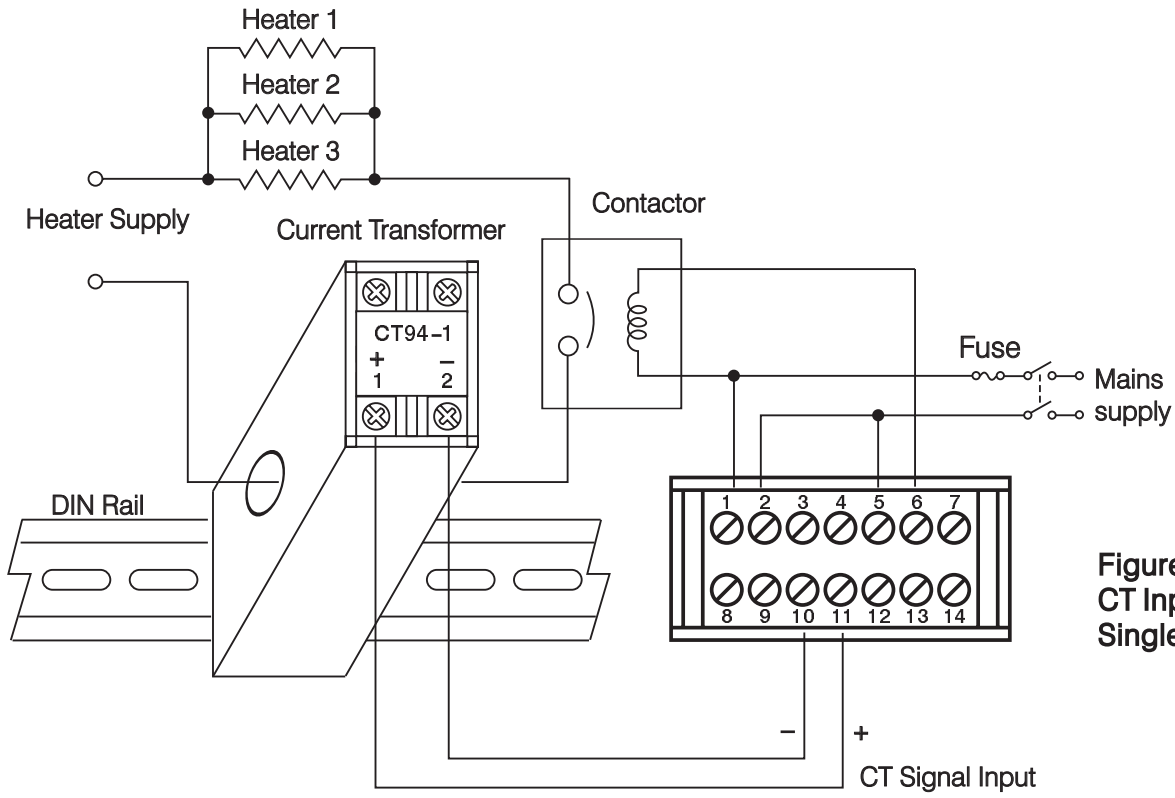

Figure 2.11
CT Input Wiring for
Single Phase Heater

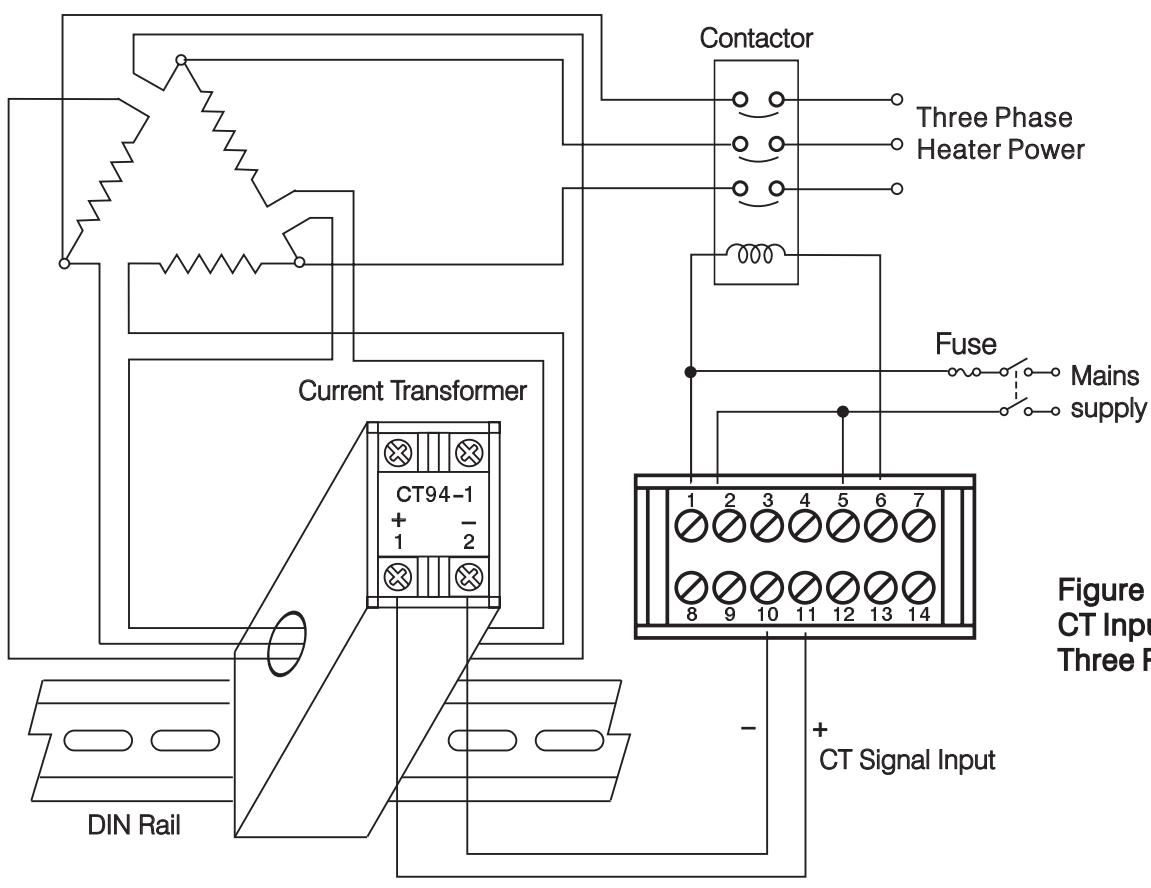

Figure 2.12
CT Input Wiring for
Three Phase Heater

Make sure that the total current through CT94-1 not exceed 50A rms.

2-10 Event Input wiring

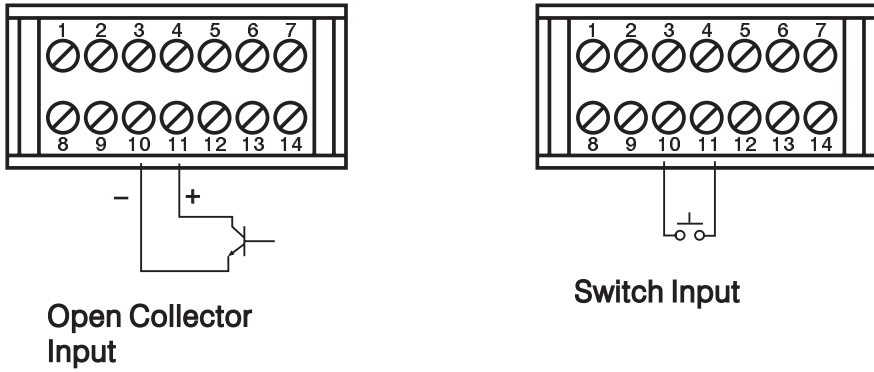
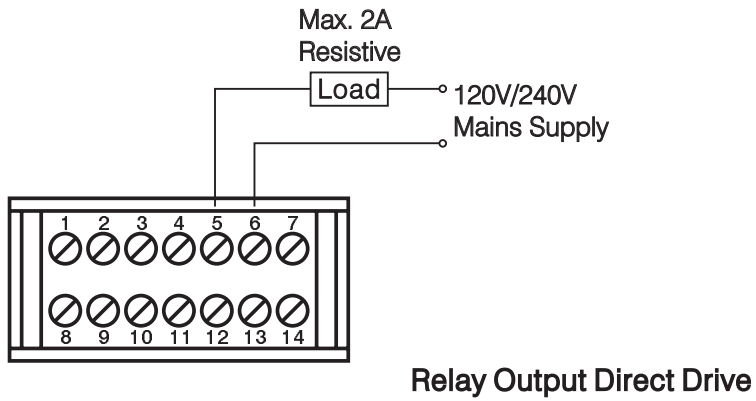

Figure 2.13
Event Input Wiring

The event input can accept a switch signal as well as an open collector signal. The event input function (EIFN) is activated as the switch is closed or an open collector (or a logic signal) is pulled down.

Also refer to **Section 4-1** for event input function.

2-11 Output 1 Wiring



Relay Output Direct Drive

Figure 2.14 Output 1 Wiring

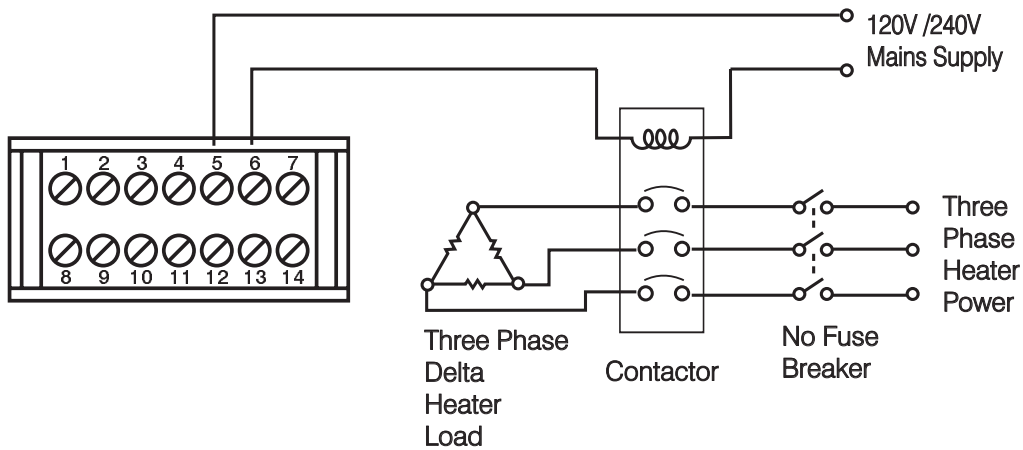

Relay or Triac (SSR) Output to Drive Contactor

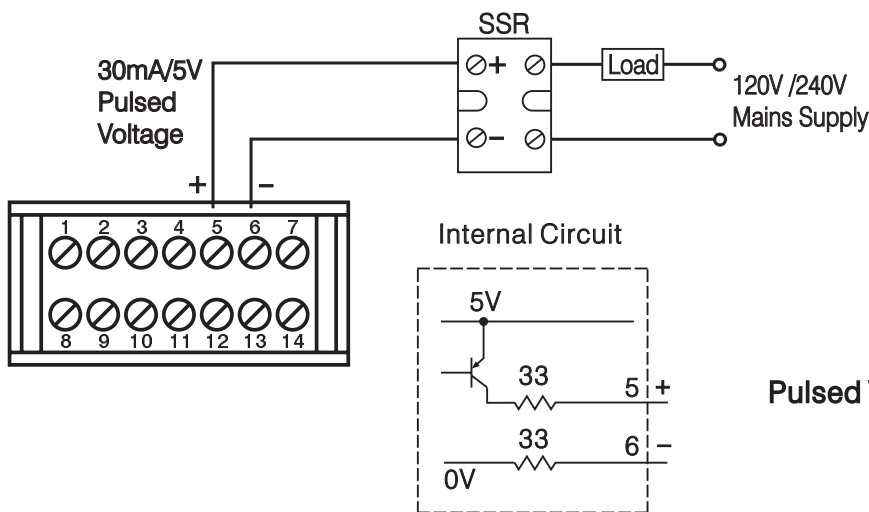

Pulsed Voltage to Drive SSR

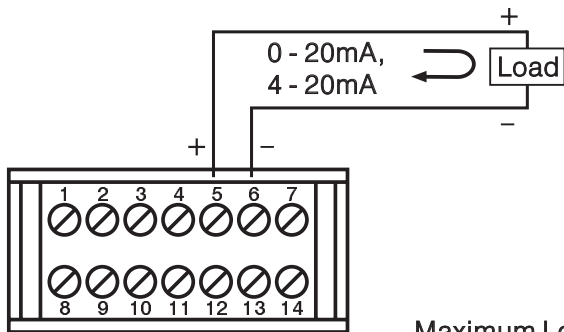

Maximum Load 500 ohms

Linear Current

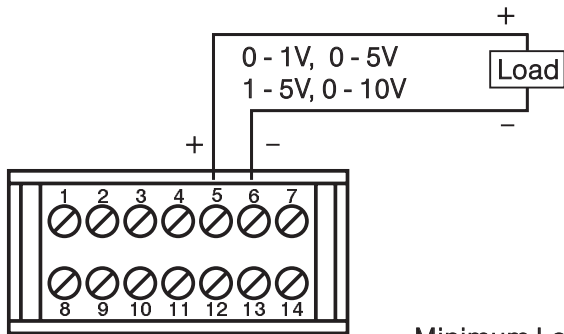

Minimum Load 10 K ohms

Linear Voltage

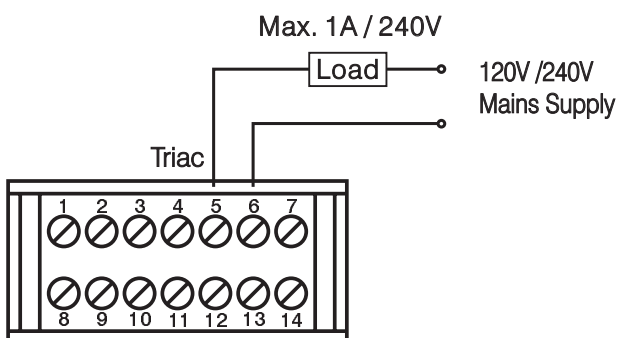

**Triac (SSR) Output
Direct Drive**

2-12 Output 2 Wiring

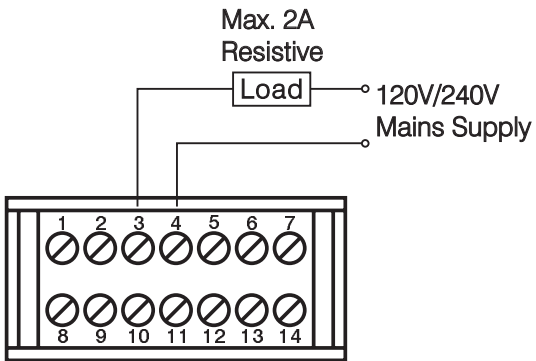

Relay Output Direct Drive

Figure 2.15 Output 2 Wiring

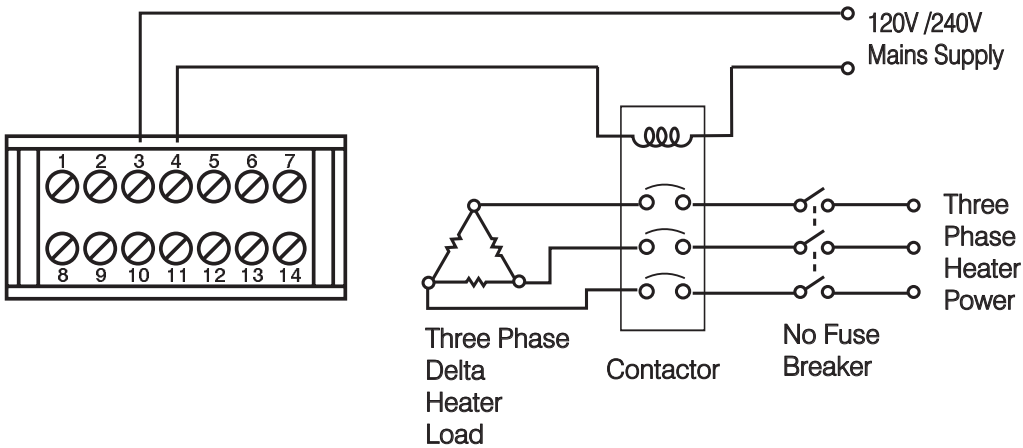

Relay or Triac (SSR) Output to Drive Contactor

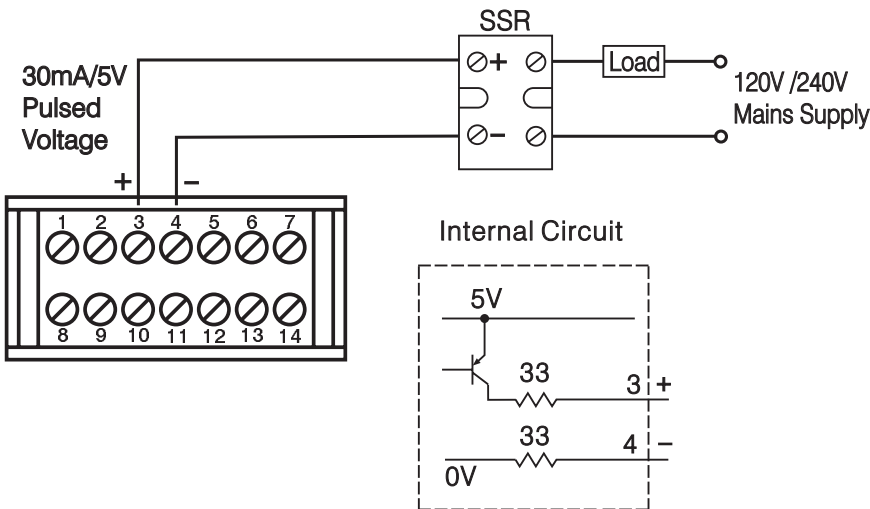

Pulsed Voltage to Drive SSR

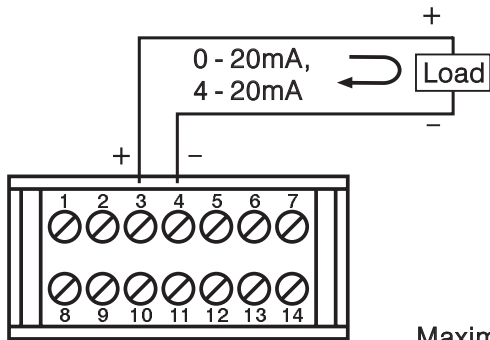

Maximum Load 500 ohms

Linear Current

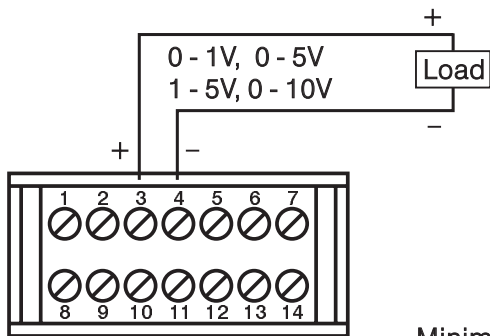

Minimum Load 10 K ohms

Linear Voltage

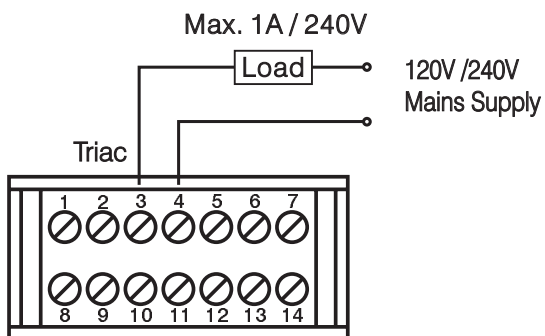

**Triac (SSR) Output
Direct Drive**

2-13 Alarm 1 Wiring

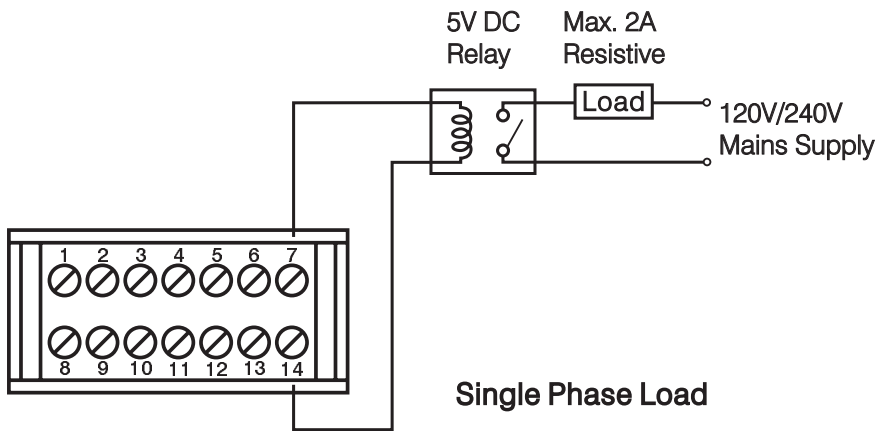
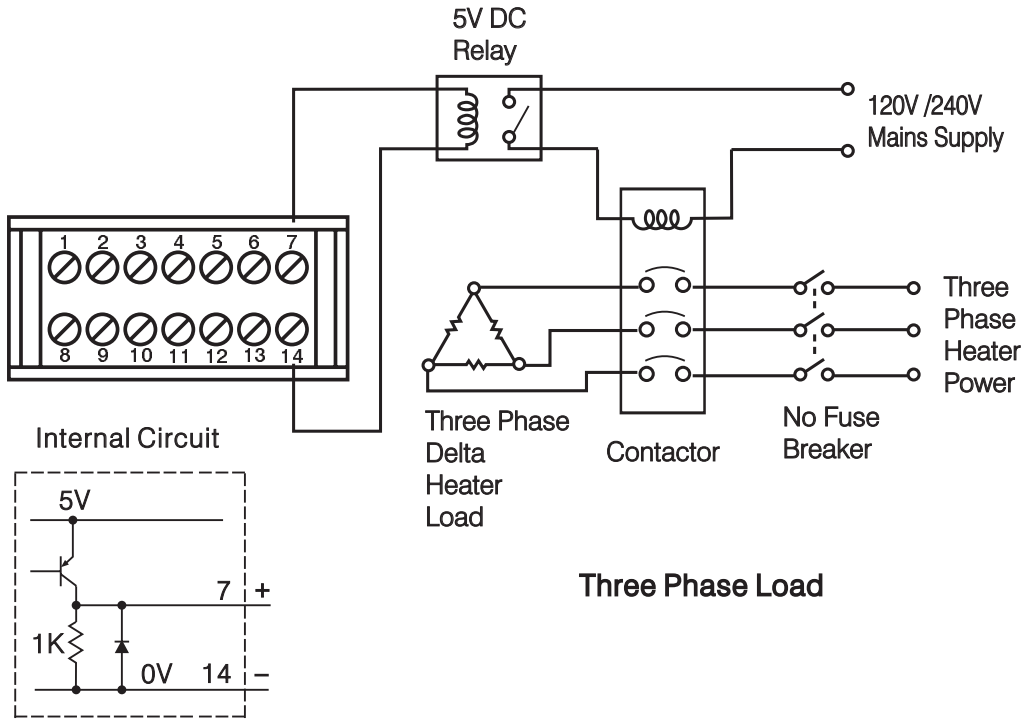

Figure 2.16
Alarm 1 Wiring



2-14 Alarm 2 Wiring

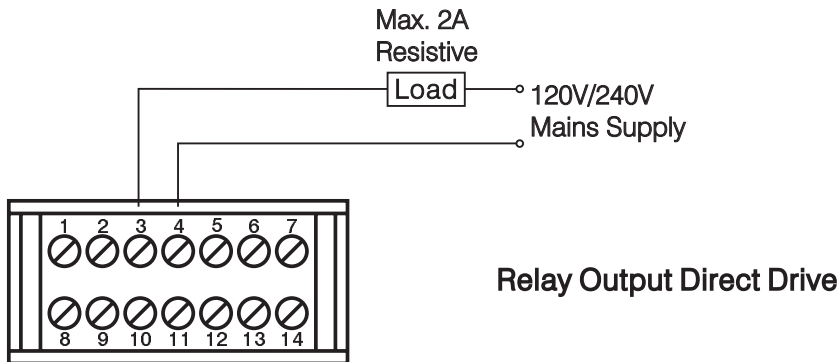
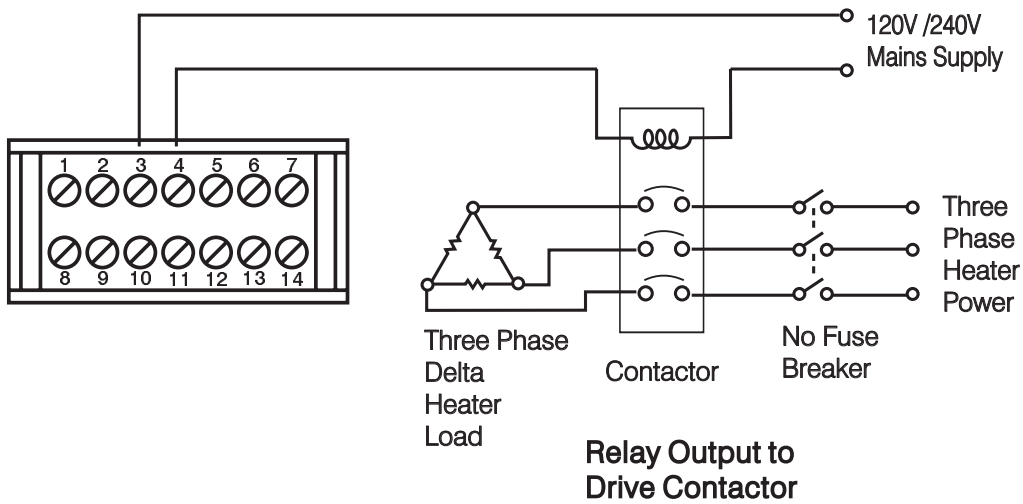
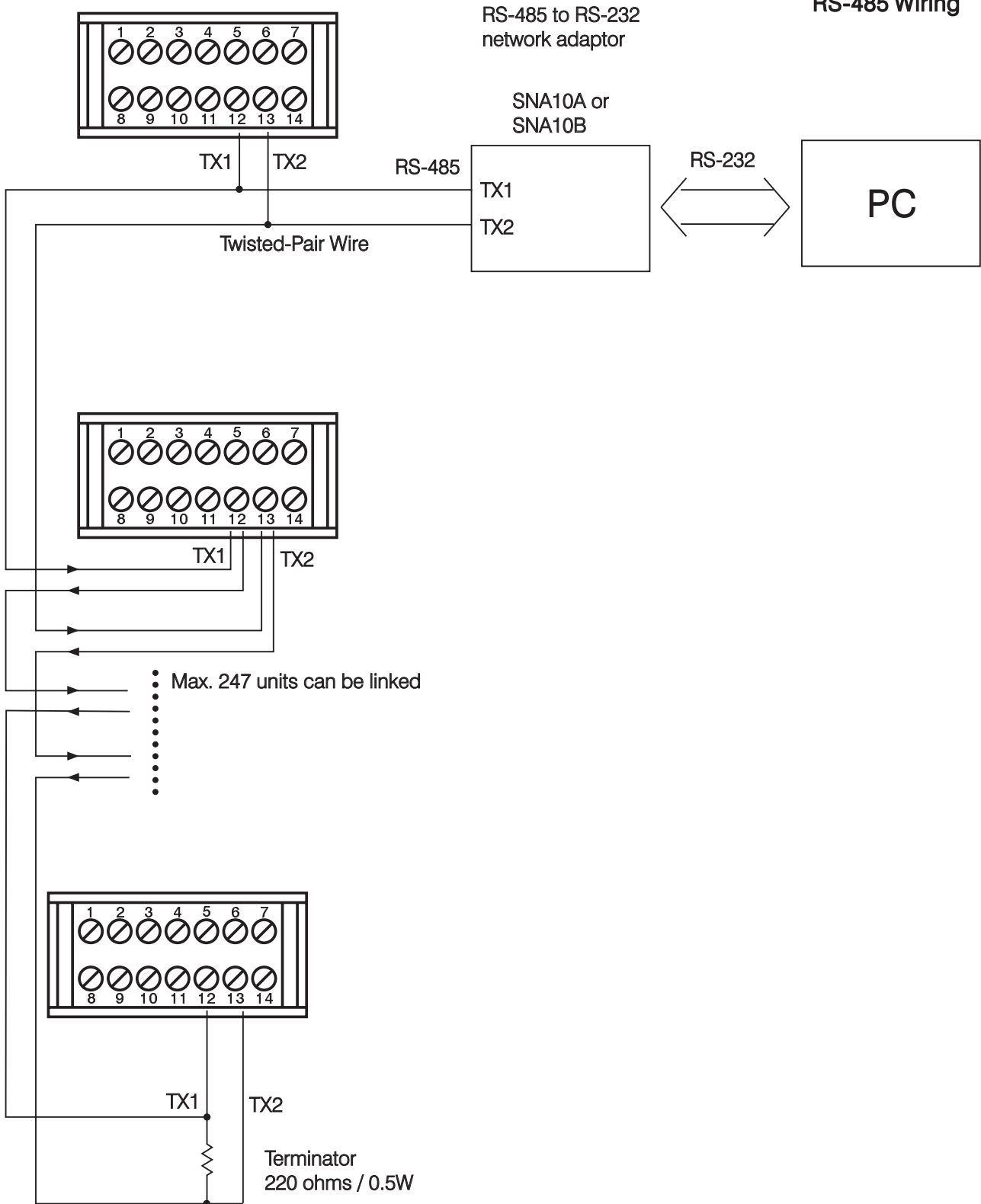

Figure 2.17 Alarm 2 Wiring



2-15 RS-485

Figure 2.18
RS-485 Wiring



2-16 RS-232

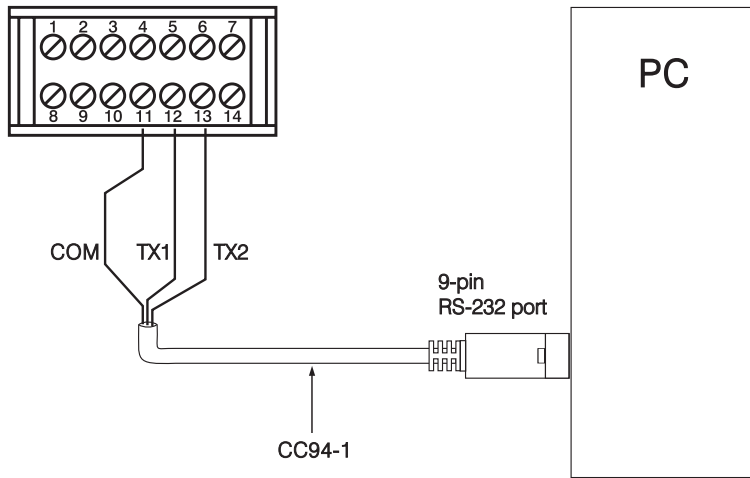

Figure 2.19
RS-232 Wiring

Note: If the BTC-2500 is configured for RS-232 communication, the input 2 and EI (Event Input) are disconnected internally. The unit can no longer perform event input function (EIFN) and input 2 function.

When you insert a RS-232 module (CM94-2) to the connectors on CPU board (C250), the jumper J51 and J52 **must** be modified as following: J52 must be shorted and J51 must be cut and left open. Location of jumper is shown in the following diagram.

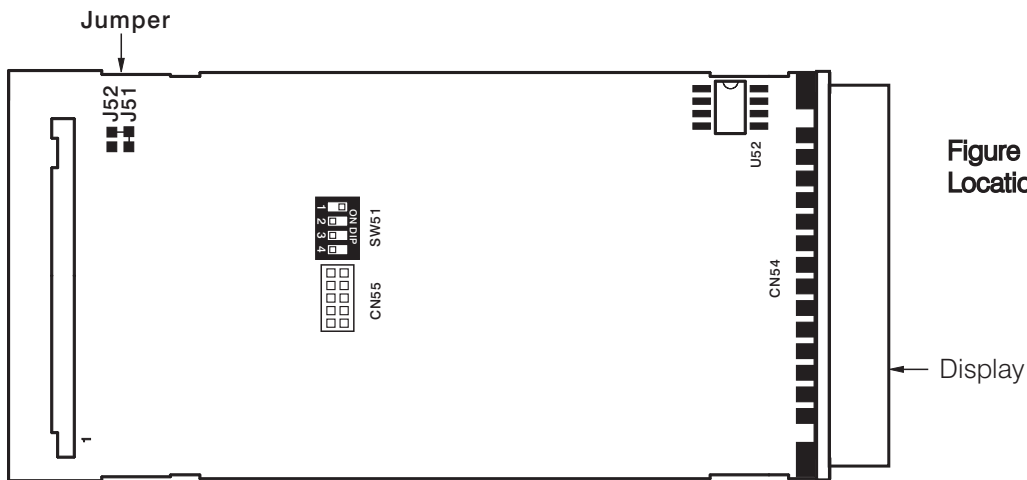

Figure 2.20
Location of Jumper J51/J52

If you use a conventional 9-pin RS-232 cable instead of CC94-1, the cable must be modified according to the following circuit diagram.

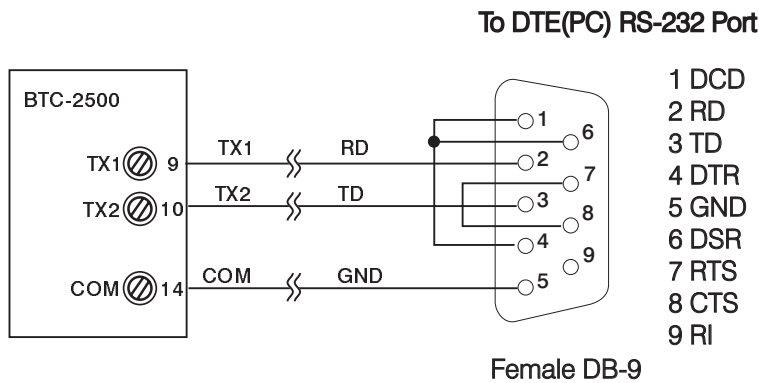

Figure 2.21
Configuration of RS-232
Cable

2-17 Analog Retransmission

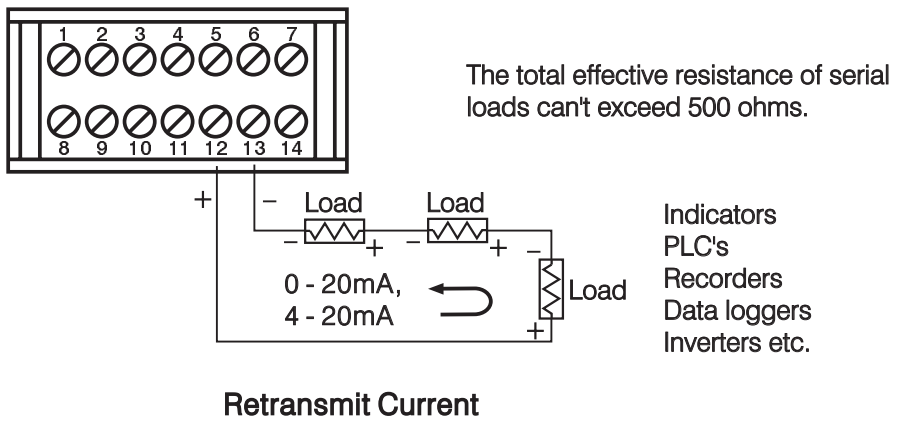
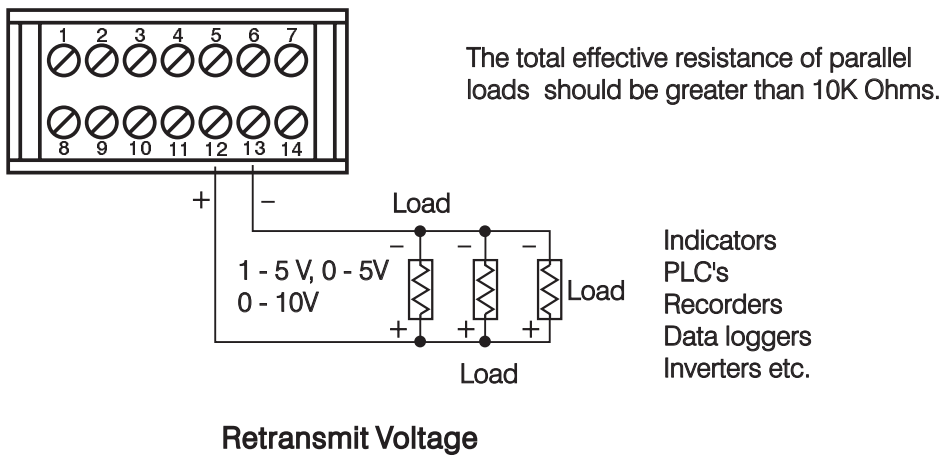

Figure 2.22 Analog Retransmission Wiring



2-18 Programming Port

See Figure 1.3 in Section 1-3 to find the programming port location.

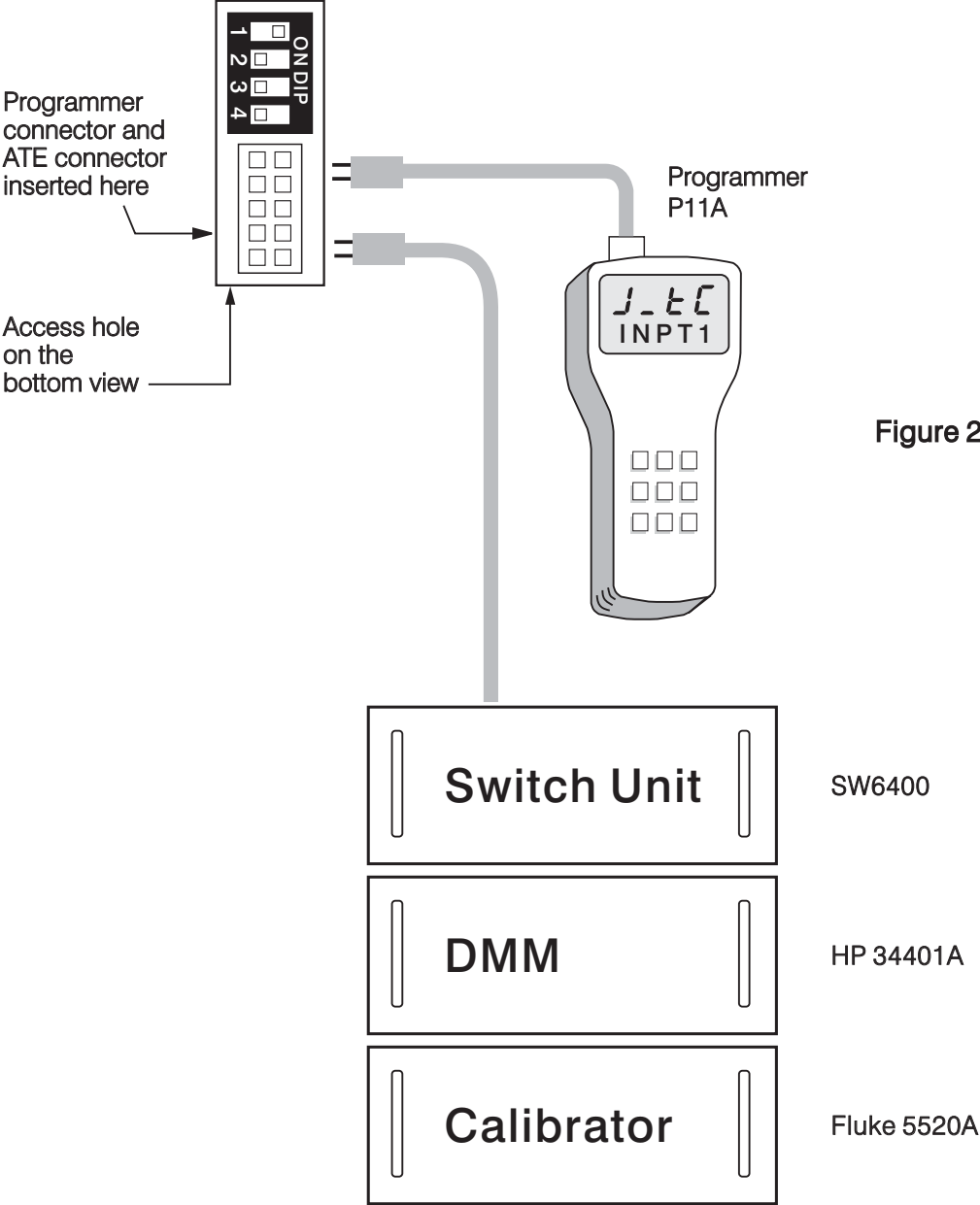

Figure 2.23 Programming Port Wiring

NOTE
The programming port is used for off-line automatic setup and testing procedures only. Don't attempt to make any connection to these pins when the unit is used for a normal control purpose.

Chapter 3 Programming the Basic Function

This unit provides an useful parameter " FUNC " which can be used to select the function complexity level before setup. If the Basic Mode (FUNC = BASC) is selected for a simple application, then the following functions are ignored and deleted from the full function menu:

RAMP, SP2, PB2, TI2, TD2, PL1, PL2, COMM, PROT, ADDR, BAUD, DATA, PARI, STOP, AOFN, AOLO, AOHI, IN2, IN2U, DP2, IN2L, IN2H, EIFN, PVMD, FILT, SLEP, SPMD and SP2F.

Basic Mode capabilities:



- (1) Input 1: Thermocouple, RTD, Volt, mA
- (2) Input 2: CT for heater break detection
- (3) Output 1: Heating or Cooling (Relay, SSR, SSRD, Volt, mA)
- (4) Output 2 : Cooling (Relay, SSR, SSRD, Volt, mA), DC Power supply.
- (5) Alarm 1: Relay for Deviation, Deviation Band, Process, Heater Break, Loop Break, Sensor Break, Latch, Hold or Normal Alarm.
- (6) Alarm 2: Relay for Deviation, Deviation Band, Process, Heater Break, Loop Break, Sensor Break, Latch, Hold or Normal Alarm.
- (7) Dwell Timer
- (8) Heater Break Alarm
- (9) Loop Break Alarm
- (10) Sensor Break Alarm
- (11) Failure Transfer
- (12) Bumpless Transfer
- (13) PV1 Shift
- (14) Programmable SP1 Range
- (15) Heat-Cool control
- (16) Hardware Lockout
- (17) Self-Tune
- (18) Auto-Tune
- (19) ON-OFF, P, PD, PI, PID Control
- (20) User Defined Menu (SEL)
- (21) Manual Control
- (22) Display Mode
- (23) Reload Default Values
- (24) Isolated DC Power Supply
- (25) PV or SV Selection

If you don't need:

- (1) Second setpoint
- (2) Second PID
- (3) Event input
- (4) Soft start (RAMP)
- (5) Remote set point
- (6) Complex process value
- (7) Output power limit
- (8) Digital communication
- (9) Analog retransmission
- (10) Power shut off (Sleep Mode)
- (11) Digital filter
- (12) Pump control
- (13) Remote lockout

then you can use Basic Mode.

3-1 Input 1

Press   to enter Setup Mode. Press  to select parameter. The upper display indicates the parameter symbol, and the lower display indicates the selection or the value of parameter.

IN1 : Selects the sensor type and signal type for Input 1.

Range: (Thermocouple) J_TC, K_TC, T_TC, E_TC, B_TC, R_TC, S_TC,
N_TC, L_TC

(RTD) PT.DN, PT.JS

(Linear) 4-20, 0-20, 0-1V, 0-5V, 1-5V, 0-10

Default : J_TC if °F is selected, K_TC if °C is selected.

IN1

IN1U: Selects the process unit for Input 1.

Range: °C, °F, PU (process unit) If the unit is neither °C nor °F, then selects PU.

Default: °C or °F.

IN1U

DP1 : Selects the location of the decimal point for most (not all) process related parameters.

Range: (For T/C and RTD) NO.DP, 1-DP
(For Linear) NO.DP, 1-DP, 2-DP, 3-DP

Default: 1-DP

DP1

IN1L : Selects the low scale value for the Linear type input 1.
Hidden if : T/C or RTD type is selected for IN1.

IN1L
IN1L

IN1H : Selects the high scale value for the Linear type input 1.
Hidden if : T/C or RTD type is selected for IN1.

IN1H
IN1H

How to use IN1L and IN1H :

If 4 - 20 mA is selected for IN1, let SL specifies the input signal low (ie. 4 mA), SH specifies the input signal high (ie. 20 mA), S specifies the current input signal value, the conversion curve of the process value is shown as follows :

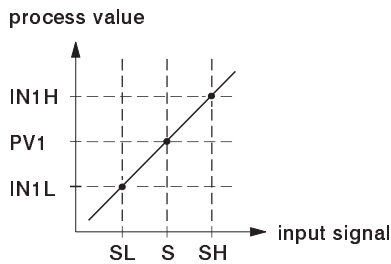

Figure 3.1 Conversion Curve for Linear Type Process Value

$$\text{Formula : } PV1 = IN1L + (IN1H - IN1L) \frac{S - SL}{SH - SL}$$

Example : A 4-20 mA current loop pressure transducer with range 0 - 15 kg/cm² is connected to input 1, then perform the following setup :

IN1 = 4 - 20 IN1L = 0.0
IN1U = PU IN1H = 15.0
DP1 = 1-DP

Of course, you may select other value for DP1 to alter the resolution.

3-2 OUT1 & OUT2 Types

O1TY : Selects the signal type for Output 1.

The selection should be consistent with the output 1 module installed.

The available output 1 signal types are :

- RELY : Mechanical relay
- SSRD : Pulsed voltage output to drive SSR
- SSR : Isolated zero-switching solid state relay
- 4 - 20 : 4 - 20 mA linear current output
- 0 - 20 : 0 - 20 mA linear current output
- 0 - 1 V : 0 - 1 V linear voltage output
- 0 - 5 V : 0 - 5 V linear voltage output
- 1 - 5 V : 1 - 5 V linear voltage output
- 0 - 10V : 0 - 10 V linear voltage output

O1TY
O1TY

O2TY
O2TY

O2TY : Selects the signal type for Output 2

The selection should be consistent with the output 2 module installed.

The available output 2 signal types are the same as for O1TY.

The range for linear current or voltage may not be very accurate. For 0 % output, the value for 4 - 20 mA may be 3.8 mA to 4 mA; while for 100 % output, the value for 4 - 20 mA may be 20 mA to 21 mA. However, this deviation will not degrade the control performance at all.

3-3 Rearrange User Menu

The conventional controllers are designed with a fixed parameters' scrolling. If you need a more friendly operation to suit your application, the manufacturer will say " sorry " to you. The BTC-2500 has the flexibility for you to select those parameters which are most significant to you and put these parameters in the front of display sequence.

- SEL1 : Selects the most significant parameter for view and change.
 - SEL2 : Selects the 2'nd significant parameter for view and change.
 - SEL3 : Selects the 3'rd significant parameter for view and change.
 - SEL4 : Selects the 4'th significant parameter for view and change.
 - SEL5 : Selects the 5'th significant parameter for view and change.
- Range : NONE, TIME, A1.SP, A1.DV, A2.SP, A2.DV, RAMP, OFST, REFC, SHIF, PB1, TI1, TD1, C.PB, DB, SP2, PB2, TI2, TD2

When using the up-down key to select the parameters, you may not obtain all of the above parameters. The number of visible parameters is dependent on the setup condition. The hidden parameters for the specific application are also deleted from the SEL selection.

Example :

- A1FN selects TIMR
 - A2FN selects DE.HI
 - PB1 = 10
 - TI1 = 0
 - SEL1 selects TIME
 - SEL2 selects A2.DV
 - SEL3 selects OFST
 - SEL4 selects PB1
 - SEL5 selects NONE
- Now, the upper display scrolling becomes :

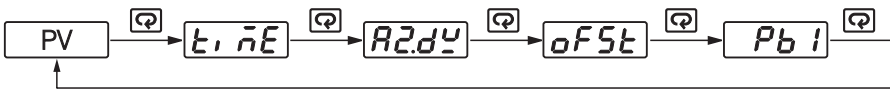

3-4 Display SV Instead of PV

In certain applications where set point value (SV) is more important than process value (PV) for the user, the parameter DISF (display format) then can be used to achieve this purpose.

Press keys to enter setup menu **SEL**, then press several times until appears on the display. If you need the process value to be displayed, then select by using or key for DISF, If you need set point value instead of process value to be displayed, then select for DISF. Also refer to the flow chart in Section 1-5 to see the location of DISF.

- SEL1
- SEL2
- SEL3
- SEL4
- SEL5

DISF has two values:

- Display process value
- Display set point value

3-5 Heat Only Control

Heat Only ON-OFF Control : Select REVR for OUT1, Set PB1 to 0, SP1 is used to adjust set point value, O1HY is used to adjust dead band for ON-OFF control, TIME is used to adjust the dwell timer (enabled by selecting TIMR for A1FN or A2FN). The output 1 hysteresis (O1HY) is enabled in case of PB1 = 0 . The heat only on-off control function is shown in the following diagram :

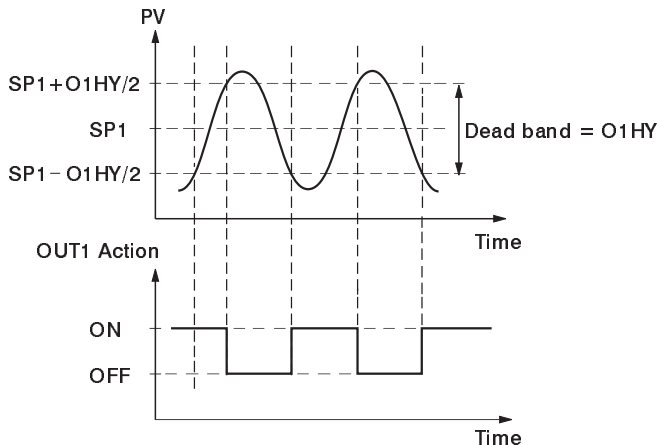

Setup ON-OFF :

OUT1 = $\boxed{rE\bar{u}r}$

PB1 = 0

Adjust : SP1, O1HY, TIME(if enabled)

Figure 3.2 Heat Only ON-OFF Control

The ON-OFF control may introduce excessive process oscillation even if hysteresis is minimized to the smallest. If ON-OFF control is set (ie. PB1 = 0), TI1, TD1, CYC1, OFST, CPB and PL1 will be hidden and have no function to the system. The manual mode, auto-tuning, self-tuning and bumpless transfer will be disabled too.

Heat only P (or PD) control : Select REVR for OUT1, set TI1 to 0, SP1 is used to adjust set point value, TIME is used to adjust the dwell timer (enabled by selecting TIMR for A1FN or A2FN). OFST been enabled in case of TI1 = 0 is used to adjust the control offset (manual reset). Adjust CYC1 according to the output 1 type (O1TY). Generally, CYC1 = 0.5 ~ 2 sec for SSRD and SSR, CYC1 = 10 ~ 20 sec for relay output .CYC1 is ignored if linear output is selected for O1TY. **O1HY is hidden** if PB1 is not equal to 0.

OFST Function : OFST is measured by % with range 0 - 100.0 %. In the steady state (ie. process has been stabilized) if the process value is lower than the set point a definite value, say 5 °C, while 20 °C is used for PB1, that is lower 25 %, then increase OFST 25 %, and vice versa. After adjusting OFST value, the process value will be varied and eventually, coincide with set point.

Using the P control (TI1 set to 0), the auto-tuning and self-tuning are disabled. Refer to section 3-21 " manual tuning " for the adjustment of PB1 and TD1. Manual reset (adjust OFST) is not practical because the load may change from time to time and often need to adjust OFST repeatedly. The PID control can avoid this situation.

Heat only PID control : Selecting REVR for OUT1, SP1 is used to adjust set point value. TIME is used to adjust the dwell timer (enabled by selecting TIMR for A1FN or A2FN). PB1 and TI1 should not be zero. Adjust CYC1 according to the output 1 type (O1TY). Generally, CYC1 = 0.5 ~ 2 sec for SSRD and SSR, CYC1 = 10 ~ 20 sec for relay output. CYC1 is ignored if linear output is selected for O1TY.

In most cases the self-tuning can be used to substitute the auto-tuning. See **Section 3-19**. If self-tuning is not used (select NONE for SELF), then use auto-tuning for the new process, or set PB1, TI1 and TD1 with historical values. See section 3-20 for auto-tuning operation. If the control result is still unsatisfactory, then use manual tuning to improve the control . See section 3-21 for manual tuning. BTC-2500 contains a **very clever PID and Fuzzy** algorithm to achieve a **very small overshoot and very quick response** to the process if it is properly tuned.

Setup P:

OUT1 = $\boxed{rE\bar{u}r}$

TI1 = 0

CYC1 (if RELAY, SSRD or SSR is selected for O1TY)

Adjust :

SP1, OFST, TIME (if enabled), PB1 (≠ 0), TD1

Setup PID :

OUT1 = $\boxed{rE\bar{u}r}$

O1TY

CYC1 (if RELAY, SSRD or SSR is selected for O1TY)

SELF = NONE or YES

Adjust:

SP1, TIME (if enabled), PB1 (≠ 0), TI1 (≠ 0), TD1.

Auto-tuning:

Used for new process. during initial tuning

Self-tuning:

Used for a process any time.

Manual Tuning:

May be used if self-tuning and auto-tuning are inadequate.

3-6 Cool Only Control

ON-OFF control, P (PD) control and PID control can be used for cool control. Set OUT1 to DIRT (direct action). The other functions for **cool only ON-OFF** control, **cool only P (PD)** control and **cool only PID** control are same as descriptions in section 3-5 for heat only control except that the output variable (and action) for the cool control is inverse to the heat control, such as the following diagram shows:

Setup Cool Control :
 OUT1 = d, r t

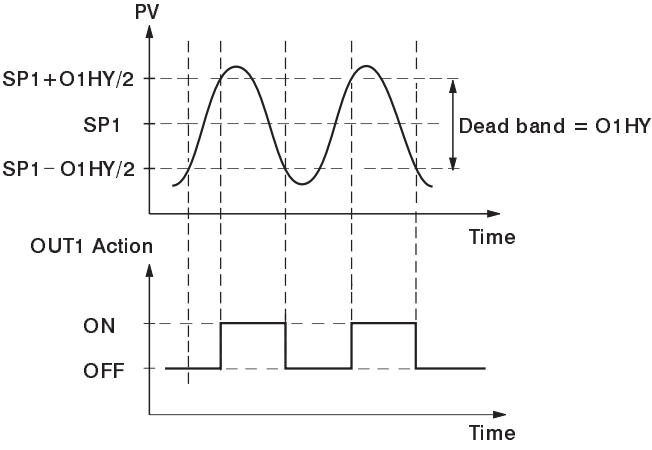

Figure 3.3 Cool Only ON-OFF Control

Refer to section 3-5 in which similar descriptions for heat only control can be applied to cool only control.

3-7 Heat-Cool Control

The Heat-Cool Control can use one of 6 combinations of control modes. Setup of parameters for each control mode are shown in the following table.

Control Modes	Heat Uses	Cool Uses	Setup Values											
			OUT1	OUT2	O1HY	OFST	PB1	TI1	TD1	CPB	DB	A2FN	A2MD	A2HY
Heat : ON-OFF Cool : ON-OFF	OUT1	OUT2	REVR	=AL2	☆	×	=0	×	×	×	×	DE.HI or PV1.H	NORM	☆
Heat : ON-OFF Cool : P (PD)	OUT2	OUT1	DIRT	=AL2	×	☆	≠0	=0	☆	×	×	DE.LO or PV1.L	NORM	☆
Heat : ON-OFF Cool : PID	OUT2	OUT1	DIRT	=AL2	×	×	≠0	≠0	☆	×	×	DE.LO or PV1.L	NORM	☆
Heat : P (PD) Cool : ON-OFF	OUT1	OUT2	REVR	=AL2	×	☆	≠0	=0	☆	×	×	DE.HI or PV1.H	NORM	☆
Heat : PID Cool : ON-OFF	OUT1	OUT2	REVR	=AL2	×	×	≠0	≠0	☆	×	×	DE.HI or PV1.H	NORM	☆
Heat : PID Cool : PID	OUT1	OUT2	REVR	COOL	×	×	≠0	≠0	☆	☆	☆	×	×	×

× : Don't care

☆ : Adjust to meet process requirements

Table 3.1 Heat-Cool Control Setup

NOTE : The ON-OFF control may result excessive overshoot and undershoot problems in the process. The P (or PD) control will result in a deviation process value from the set point. It is recommended to use PID control for the Heat-Cool control to produce a stable and zero offset process value.

Other Setup Required : O1TY, CYC1, O2TY, CYC2, A2SP, A2DV

O1TY & O2TY are set in accordance with the types of OUT1 & OUT2 installed. CYC1 & CYC2 are selected according to the output 1 type (O1TY) & output 2 type (O2TY).

Generally, selects 0.5 ~ 2 sec. for CYC1, if SSRD or SSR is used for O1TY; 10 ~ 20 sec. if relay is used for O1TY, and CYC1 is ignored if linear output is used. Similar condition is applied for CYC2 selection.

If OUT2 is configured for ON-OFF control (by selecting = AL2), the OUT2 acts as alarm output, and the process alarm as well as deviation alarm (see section 3-9 & 3-10) can be used. Adjust A2SP to change set point if process alarm is used, and adjust SP1 (with preset A2DV) to change set point if deviation alarm is used.

Examples:

Heat PID+Cool ON-OFF : Set OUT1= REVR, OUT2= =AL2, A2FN= PV1.H, A2MD=NORM, A2HY=0.1, PB1≠0, TI1≠0,TD1≠0, and set appropriate values for O1TY and CYC1.

Heat PID+Cool PID : set OUT1=REVR, OUT2=COOL, CPB=100, DB=-4.0, PB1≠0, TI1≠0 TD1≠0, and set appropriate values for O1TY, CYC1, O2TY, CYC2.

If you have no idea about a new process, then use **self-tuning** program to optimize the PID values by selecting YES for SELF to enable the self-tuning program .See section 3-19 for self-tuning description. You can use the **auto-tuning** program for the new process or directly set the appropriate values for PB1, TI1 & TD1 according to the historical records for the repeated systems. If the control behavior is still inadequate, then use **manual tuning** to improve the control. See section 3-21 for manual tuning.

CPB Programming : The cooling proportional band is measured by % of PB with range 1~255. Initially set 100% for CPB and examine the cooling effect. If cooling action should be enhanced then **decrease CPB**, if cooling action is too strong then **increase CPB**. The value of CPB is related to PB and its value remains unchanged throughout the self-tuning and auto-tuning procedures.

Adjustment of CPB is related to the cooling media used. For air is used as cooling media, adjust CPB at 100(%). For oil is used as cooling media, adjust CPB at 125(%). For water is used as cooling media, adjust CPB at 250(%).

DB Programming: Adjustment of DB is dependent on the system requirements. If more positive value of DB (greater dead band) is used, an unwanted cooling action can be avoided but an excessive overshoot over the set point will occur. If more negative value of DB (greater overlap) is used, an excessive overshoot over the set point can be minimized but an unwanted cooling action will occur. It is adjustable in the range -36.0% to 36.0 % of PB1 (or PB2 if PB2 is selected). A negative DB value shows an overlap area over which both outputs are active. A positive DB value shows a dead band area over which neither output is active.

3-8 Dwell Timer

Alarm 1 or alarm 2 can be configured as dwell timer by selecting TIMR for A1FN or A2FN, but not both, otherwise Er07 will appear. As the dwell timer is configured, the parameter TIME is used for dwell time adjustment. The dwell time is measured in minute ranging from 0 to 6553.5 minutes. Once the process reaches the set point the dwell timer starts to count from zero until time out. The timer relay will remain unchanged until time out. The dwell timer operation is shown as following diagram.

Er07 Error Code

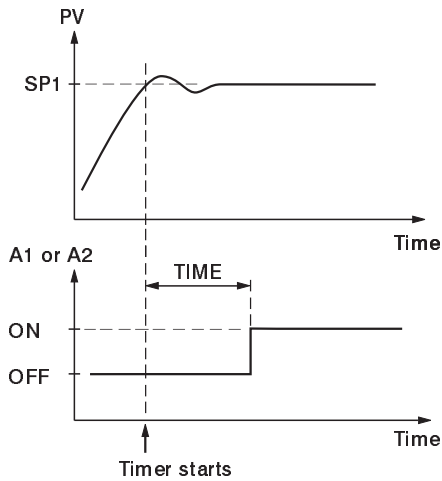

Figure 3.4 Dwell Timer Function

If alarm 1 is configured as dwell timer, A1SP, A1DV, A1HY and A1MD are hidden. Same case is for alarm 2.

Example :

Set A1FN=TIMR or A2FN=TIMR but not both.

Adjust TIME in minutes

A1MD (if A1FN=TIMR) or A2MD (if A2FN=TIMR) is ignored in this case.

If alarm 1 is selected for dwell timer, an external 5V DC relay is required to drive AC load.

3-9 Process Alarms

There are at most two independent alarms available by adjusting OUT2. If =AL2 is selected for OUT2, then OUT2 will perform alarm 2 function. Now A2FN can't be selected with NONE, otherwise Er06 will be displayed.

Er06 Error Code

A process alarm sets an absolute trigger level (or temperature). When the process (could be PV1, PV 2 or PV1-PV2) exceeds that absolute trigger level an alarm occurs. A process alarm is independent from set point.

Adjust A1FN (Alarm 1 function) in setup menu. One of 8 functions can be selected for process alarm. These are : PV1.H, PV1.L, PV2.H, PV2.L, P1.2.H, P1.2.L, D1.2.H, D1.2.L. When the PV1.H or PV1.L is selected the alarm examines the PV1 value. When the PV2.H or PV2.L is selected the alarm examines the PV2 value. When the P1.2.H or P1.2.L is selected the alarm occurs if the PV1 or PV2 value exceed the trigger level. When the D1.2.H or D1.2.L is selected the alarm occurs if the PV1-PV2 (difference) value exceeds the trigger level. The trigger level is determined by A1SP (Alarm 1 set point) and A1HY (Alarm 1 hysteresis value) in User Menu for alarm 1. The hysteresis value is introduced to avoid interference action of alarm in a noisy environment. Normally A1HY can be set with a minimum (0.1) value.

A1DV and/or A2DV are hidden if alarm 1 and/or alarm 2 are set with process alarm.

Normal Alarm : A1MD = NORM

When a normal alarm is selected, the alarm output is de-energized in the non-alarm condition and energized in an alarm condition.

8 Types of Process Alarms :

PV1.H, PV1.L, PV2.H, PV2.L, P1.2.H, P1.2.L, D1.2.H, D1.2.L

Latching Alarm : A1MD = LTCH

If a latching alarm is selected, once the alarm output is energized, it will remain unchanged even if the alarm condition is cleared. The latching alarms are disabled when the power is shut off or if event input is applied with proper selection of EIFN.

Process Alarm 1

Setup : A1FN, A1MD

Adjust : A1SP, A1HY

Trigger level = $A1SP \pm 1/2 A1HY$

Holding Alarm : A1MD = HOLD

A holding alarm prevents an alarm from power up. The alarm is enabled only when the process reaches the set point value (may be SP1 or SP2, See section 4-1 event input). Afterwards, the alarm performs same function as normal alarm.

Process Alarm 2

Setup : OUT2, A2FN, A2MD

Adjust : A2SP, A2HY

Trigger level = $A2SP \pm 1/2 A2HY$

Latching / Holding Alarm : A1MD = LT.HO

A latching / holding alarm performs both holding and latching function.

Reset Latching alarm

1. Power off
2. Apply Event input in accordance with proper selection of EIFN

Examples:

A1SP = 200 A1HY = 10.0
A1MD = NORM A1FN = PV1.H

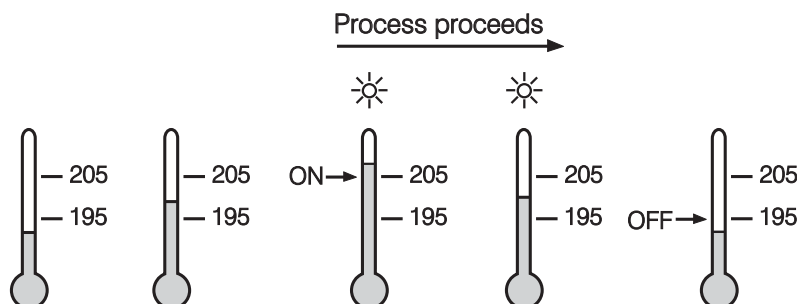

Figure 3.5
Normal Process Alarm

(3-9 2'nd page)

A1SP = 200 A1HY = 10.0
 A1MD = LTCH A1FN = PV1.H

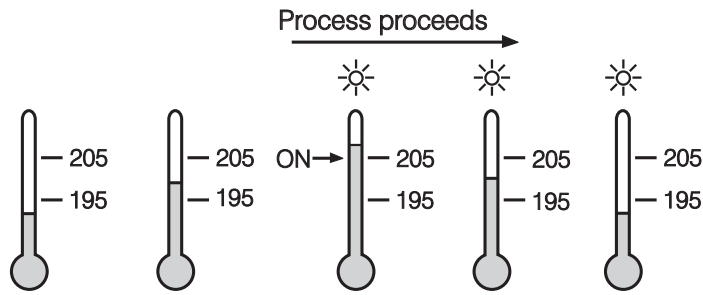

Figure 3.6
Latching Process Alarm

A1SP = 200 A1HY = 10.0 SP1 = 210
 A1MD = HOLD A1FN = PV1.L

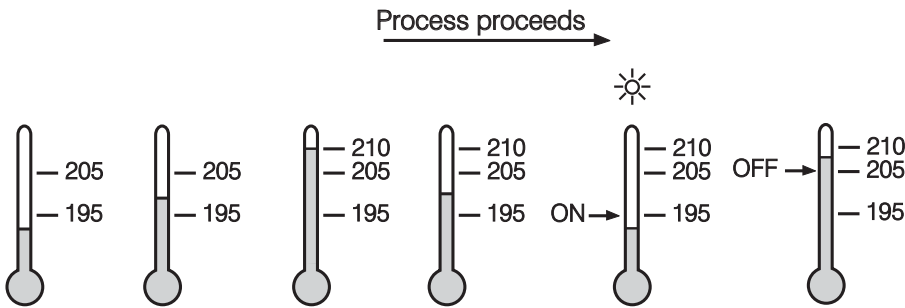

Figure 3.7
Holding Process Alarm

A1SP = 200 A1HY = 10.0 SP1 = 210
 A1MD = LT.HO A1FN = PV1.L

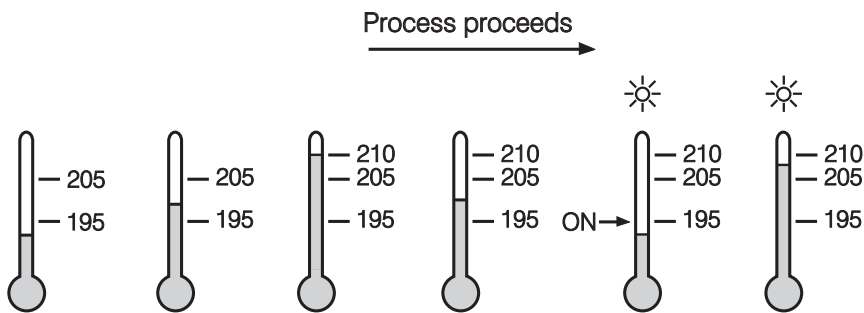

Figure 3.8
Latching / Holding Process Alarm

Although the above descriptions are based on alarm 1, the same conditions can be applied to alarm 2.

3-10 Deviation Alarm

OUT2 can be configured as alarm 2 by selecting=AL2. If OUT2 selects=AL2, then output 2 will perform alarm 2 function. Now A2FN can't be selected with NONE, otherwise Er06 will appear.

A deviation alarm alerts the user when the process deviates too far from set point. The user can enter a positive or negative deviation value (A1DV, A2DV) for alarm 1 and alarm 2. A hysteresis value (A1HY or A2HY) can be selected to avoid interference problem of alarm in a noisy environment. Normally, A1HY and A2HY can be set with a minimum (0.1) value.

Trigger levels of alarm are moving with set point.
 For alarm 1, Trigger levels=SP1+A1DV±1/2 A1HY.
 For alarm 2, Trigger levels=SP1+A2DV±1/2 A2HY.

A1SP and/or A2SP are hidden if alarm 1 and/or alarm 2 are set with deviation alarm. One of 4 kinds of alarm modes can be selected for alarm 1 and alarm 2. These are: Normal alarm, Latching alarm, Holding alarm and Latching/Holding alarm. See Section 3-9 for descriptions of these alarm modes.

Examples:

Er06 Error Code

2 Types of Deviation Alarms :
 DE.HI, DE.LO

Deviation Alarm 1
 Setup : A1FN, A1MD
 Adjust : SP1, A1DV, A1HY
 Trigger levels=SP1+A1DV±1/2A1HY

Deviation Alarm 2 :
 Setup : OUT2, A2FN, A2MD
 Adjust : SP1, A2DV, A2HY
 Trigger levels=SP1+A2DV±1/2A2HY

A1FN = DE.HI, A1MD = NORM, SP1 = 100, A1DV=10, A1HY=4

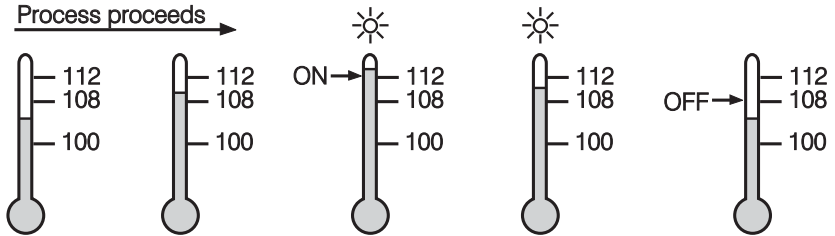

Figure 3.9
 Normal Deviation Alarm

A1FN = DE.HI, A1MD = LTCH, SP1 = 100, A1DV=10, A1HY=4

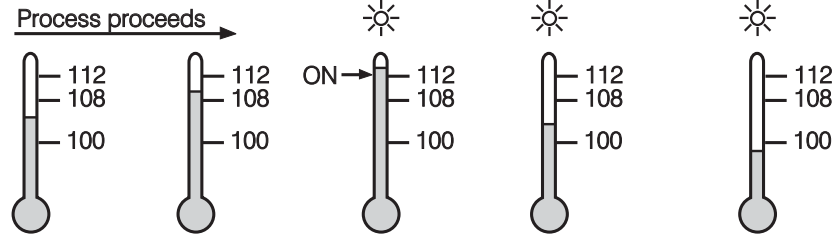

Figure 3.10
 Latching Deviation Alarm

A1HY = DE.LO, A1MD = HOLD, SP1 = 100, A1DV= -10, A1HY=4

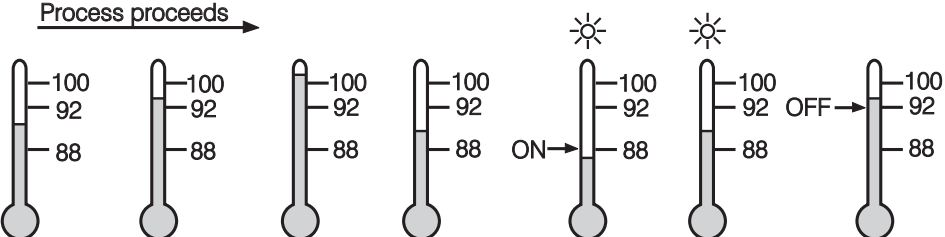

Figure 3.11 Holding
 Deviation Alarm

A1HY= DE.LO, A1MD = LT.HO, SP1 = 100, A1DV= -10, A1HY=4

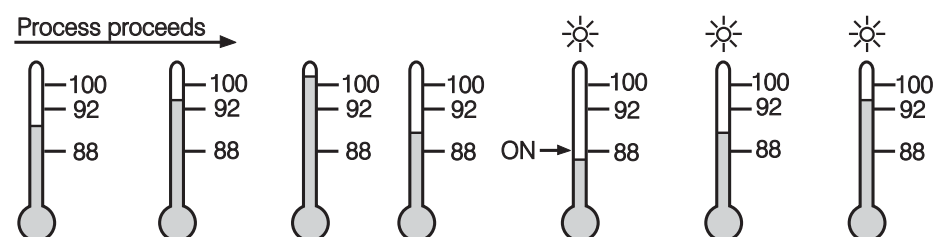

Figure 3.12
 Latching /Holding
 Deviation Alarm

3-11 Deviation Band Alarm

A deviation band alarm presets two reference levels relative to set point. Two types of deviation band alarm can be configured for alarm 1 and alarm 2. These are deviation band high alarm (A1FN or A2FN select DB.HI) and deviation band low alarm (A1FN or A2FN select DB.LO). If alarm 2 is required, then select =AL2 for OUT2. Now A2FN can't be selected with NONE, otherwise Er06 will appear. A1SP and A1HY are hidden if alarm 1 is selected with deviation band alarm. Similarly, A2SP and A2HY are hidden if alarm 2 is selected with deviation band alarm. Trigger levels of deviation band alarm are moving with set point. For alarm 1, trigger levels=SP1 ± A1DV. For alarm 2, trigger levels=SP1 ± A2DV. One of 4 kinds of alarm modes can be selected for alarm 1 and alarm 2. These are : Normal alarm, Latching alarm, Holding alarm and Latching/Holding alarm. See Section 3-9 for descriptions of these alarm modes.

2 Types of Deviation Band Alarms:
DB.HI, DB.LO

Deviation Band Alarm 1 :
Setup: A1FN, A1MD
Adjust: SP1, A1DV
Trigger levels= SP1 ± A1DV

Deviation Band Alarm 2 :
Setup : OUT2, A2FN, A2MD
Adjust : SP1, A2DV
Trigger levels = SP1 ± A2DV

Examples:

Er06 Error Code

A1FN = DB.HI, A1MD = NORM, SP1 = 100, A1DV = 5

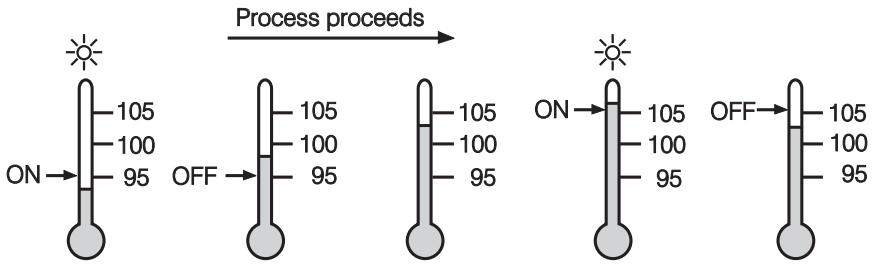

Figure 3.13
Normal Deviation
Band Alarm

A1FN = DB.LO, A1MD = LTCH, SP1 = 100, A1DV = 5

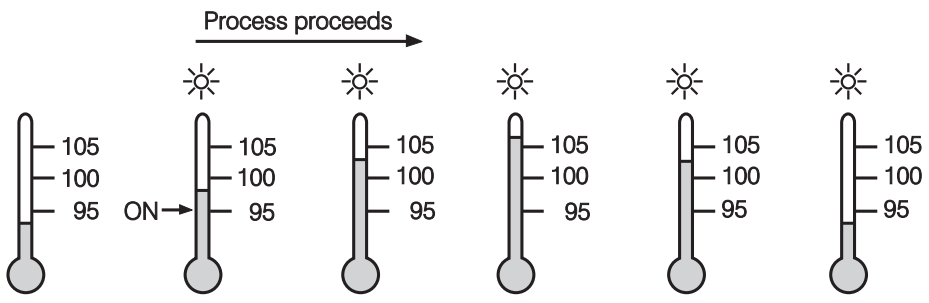

Figure 3.14
Latching Deviation
Band Alarm

A1FN = DB.HI, A1MD = HOLD, SP1 = 100, A1DV = 5

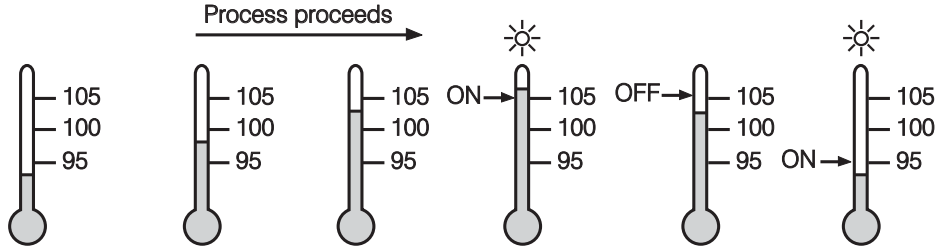

Figure 3.15
Holding Deviation
Band Alarm

A1FN = DB.HI, A1MD = LT.HO, SP1 = 100, A1DV = 5

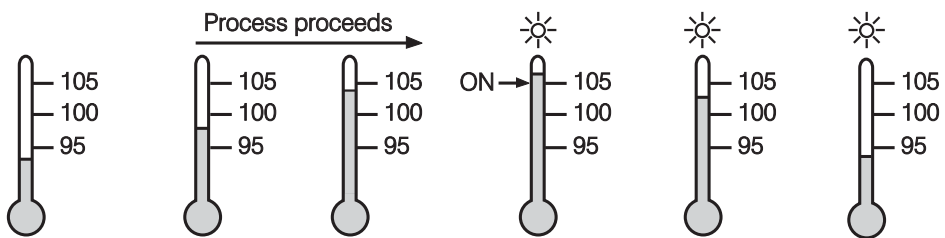

Figure 3.16
Latching /Holding
Deviation Band Alarm

3-12 Heater Break Alarm

A current transformer (parts No. CT94-1) should be installed to detect the heater current if a heater break alarm is required. The CT signal is sent to input 2, and the PV2 will indicate the heater current in 0.1 Amp. resolution. The range of current transformer is 0 to 50.0 Amp. For more detailed descriptions about heater current monitoring, please see Section 3-25.

Example:

A furnace uses two 2KW heaters connected in parallel to warm up the process. The line voltage is 220V and the rating current for each heater is 9.09A. If we want to detect any one heater break, set A1SP=13.0A, A1HY=0.1 A1FN=PV2.L, A1MD=NORM, then

Heater Break Alarm 1

Setup : IN2 = CT
 A1FN = PV2.L
 A1MD = NORM
 A1HY = 0.1

Adjust : A1SP

Trigger levels : A1SP \pm 1/2 A1HY

Heater Break Alarm 2

Setup : IN2 = CT
 A2FN = PV2.L
 A2MD = NORM
 A2HY = 0.1

Adjust : A2SP

Trigger levels : A2SP \pm 1/2 A2HY

Limitations :

1. Linear output can't use heater break alarm.
2. CYC1 should use 1 second or longer to detect heater current reliably.

No heater breaks

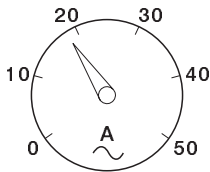

1 heater breaks

☀ Alarm !

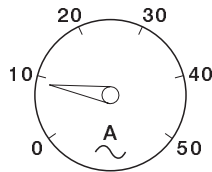

2 heaters breaks

☀ Alarm !

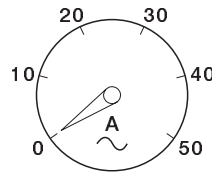

Figure 3.17
Heater Break Alarm

3-13 Loop Break Alarm

A1FN selects LB if alarm 1 is required to act as a loop break alarm. Similarly, if alarm 2 is required to act as a loop break alarm, then set OUT2 with=AL2 and A1FN with LB.

TIME, A1SP, A1DV and A1HY are hidden if alarm 1 is configured as a loop break alarm. Similarly, TIME, A2SP, A2DV and A2HY are hidden if alarm 2 is configured as a loop break alarm.

One of 4 kinds of alarm modes can be selected for alarm 1 and alarm 2. These are : Normal alarm, Latching alarm, Holding alarm and Latching/Holding alarm. However, the Holding mode and Latching/Holding mode are not recommended to be chosen for loop break alarm since loop break alarm will not perform holding function even if it is set with holding or latching/holding mode. See Section 3-9 for the descriptions of these alarm modes.

Loop Break Conditions are detected during a time interval of 2TI1 (double of integral time, but 120 seconds maximum). Hence the loop break alarm doesn't respond quickly as it occurs. If the process value doesn't increase (or decrease) while the control variable MV1 has reached to its maximum (or minimum) value within the detecting time interval, a loop break alarm (if configured) will be actuated.

Loop Break Alarm 1

Setup : A1FN = LB
A1MD = NORM, LTCH

Loop Break Alarm 2

Setup : OUT2 = =AL2
A2FN = LB
A2MD = NORM, LTCH

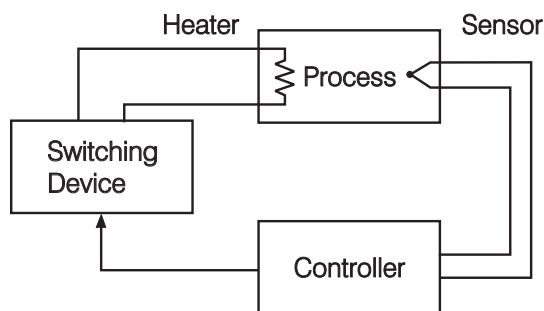

Loop Break Sources : Sensor, Controller, Heater, Switching Device

Figure 3.18
Loop Break Sources

Loop Break Alarm (if configured) occurs when any following condition happens:

1. Input sensor is disconnected (or broken).
2. Input sensor is shorted.
3. Input sensor is defective.
4. Input sensor is installed outside (isolated from) the process.
5. Controller fails (A-D converter damaged).
6. Heater (or generally, chiller, valve, pump, motor etc.) breaks or fails or uninstalled.
7. Switching device (used to drive heater) is open or shorted.

3-14 Sensor Break Alarm

Alarm 1 or alarm 2 can be configured as sensor break alarm by selecting **SEnb** for A1FN or A2FN. If alarm 2 is required for sensor break alarm, then OUT2 should be selected with =AL2.

The sensor break alarm is activated as soon as failure mode occurs. Refer to **Section 3-17** for failure mode conditions. Note that **A-D failure** also creates a sensor break alarm. TIME, A1SP, A1DV, and A1HY are hidden if alarm 1 is configured as a sensor break alarm. Similarly, TIME, A2SP, A2DV and A2HY are hidden if alarm 2 is configured as a sensor break alarm.

One of 4 kinds of alarm modes can be selected for sensor break alarm. These are: Normal alarm, Latching alarm, Holding alarm and Latching/Holding alarm. However, the Holding alarm and Latching/Holding alarm are not recommended to be chosen for sensor break alarm since sensor break alarm will not perform holding function even if it is set with holding or latching/holding mode. See **Section 3-9** for the descriptions of these alarm modes.

Sensor Break Alarm 1

Setup: A1FN=SENB
A1MD=NORM, LTCH
Hidden: TIME, A1SP, A1DV
A1HY

Sensor Break Alarm 2

Setup: OUT2= =AL2
A2FN=SENB
A2MD=NORM, LTCH
Hidden: TIME, A2SP, A2DV
A2HY

3-15 SP1 Range

SP1L (SP1 low limit value) and SP1H (SP1 high limit value) in setup menu are used to confine the adjustment range of SP1.

Setup : SP1L, SP1H

Example : A freezer is working in its normal temperature range -10 °C to -15 °C. In order to avoid an abnormal set point, SP1L and SP1H are set with the following values:

$$SP1L = -15\text{ °C} \quad SP1H = -10\text{ °C}$$

Now SP1 can only be adjusted within the range from -10 °C to -15 °C.

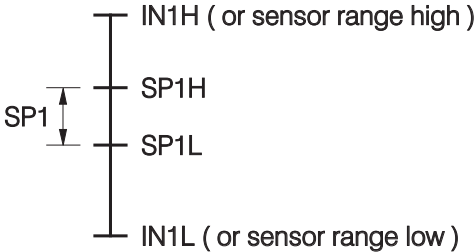

Figure 3.19 SP1 Range

3-16 PV1 Shift

In certain applications it is desirable to shift the controller display value from its actual value. This can be easily accomplished by using the PV1 shift function.

Press the " scroll " key to the parameter SHIF. The value you adjust here, either positive or negative, will be added to the actual value. The SHIF function will **alter PV1 only**.

Here is an example. A process is equipped with a heater, a sensor and a subject to be warmed up. Due to the design and position of the components in the system, the sensor could not be placed any closer to the part. Thermal gradient (different temperature) is common and necessary to an extent in any thermal system for heat to be transferred from one point to another. If the difference between the sensor and the subject is 35 °C, and the desired temperature at the subject to be heated is 200 °C, the controlling value or the temperature at the sensor should be 235 °C. You should input -35 °C as to subtract 35 °C from the actual process display. This in turn will cause the controller to energize the load and bring the process display up to the set point value.

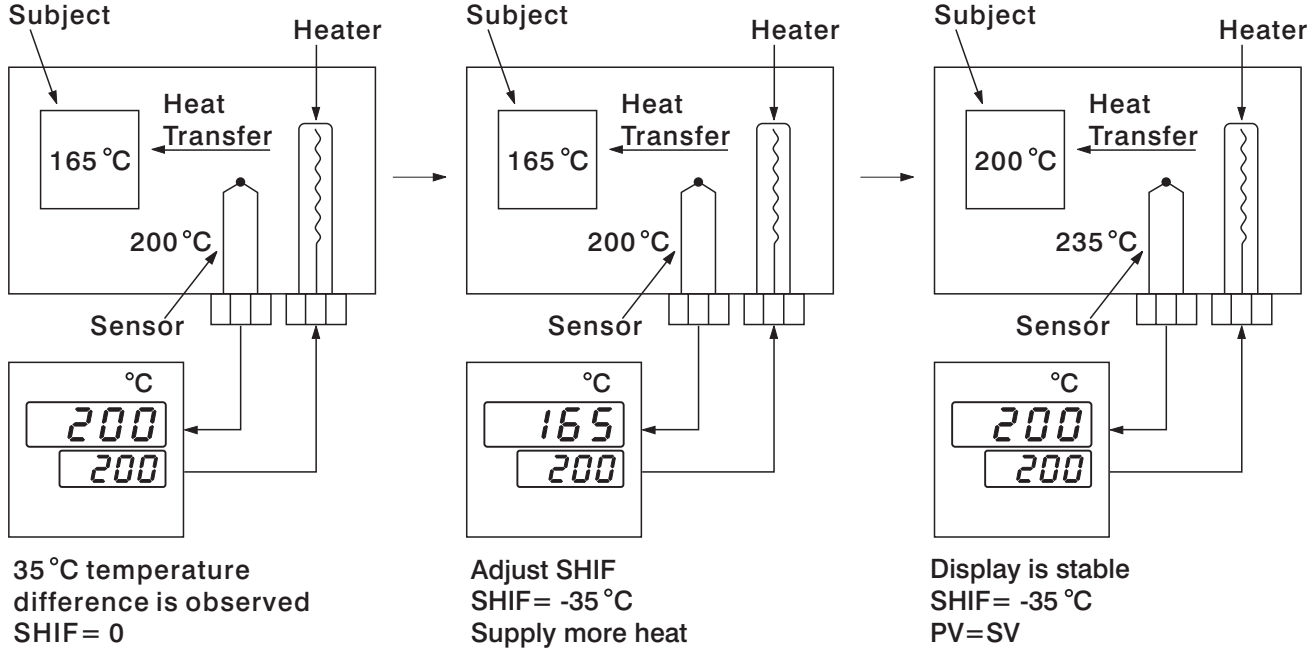

Figure 3.20
PV1 Shift Application

3-17 Failure Transfer

The controller will enter failure mode as one of the following conditions occurs:

1. SB1E occurs (due to the input 1 sensor break or input 1 current below 1mA if 4-20 mA is selected or input 1 voltage below 0.25V if 1-5 V is selected) if PV1, P1-2 or P2-1 is selected for PVMD or PV1 is selected for SPMD.
2. SB2E occurs (due to the input 2 sensor break or input 2 current below 1mA if 4-20 mA is selected or input 2 voltage below 0.25V if 1-5 V is selected) if PV2, P1-2 or P2-1 is selected for PVMD or PV2 is selected for SPMD.
3. ADER occurs due to the A-D converter of the controller fails.

The output 1 and output 2 will perform the failure transfer function as one of the following conditions occurs:

1. During power starts (within 2.5 seconds).
2. The controller enters the failure mode.
3. The controller enters the manual mode.
4. The controller enters the calibration mode.

Output 1 Failure Transfer, if activated, will perform :

1. If output 1 is configured as proportional control ($PB1 \neq 0$), and BPLS is selected for O1FT, then output 1 will perform bumpless transfer. Thereafter the previous averaging value of MV1 will be used for controlling output 1.
2. If output 1 is configured as proportional control ($PB1 \neq 0$), and a value of 0 to 100.0 % is set for O1FT, then output 1 will perform failure transfer. Thereafter the value of O1FT will be used for controlling output 1.
3. If output 1 is configured as ON-OFF control ($PB1 = 0$), then output 1 will be driven OFF if O1FN selects REVR and be driven ON if O1FN selects DIRT.

Output 2 Failure Transfer, if activated, will perform :

1. If OUT2 selects COOL, and BPLS is selected for O1FT, then output 2 will perform bumpless transfer. Thereafter the previous averaging value of MV2 will be used for controlling output 2.
2. If OUT2 selects COOL, and a value of 0 to 100.0 % is set for O2FT, then output 2 will perform failure transfer. Thereafter the value of O1FT will be used for controlling output 2.

Alarm 1 Failure Transfer is activated as the controller enters failure mode. Thereafter the alarm 1 will transfer to the ON or OFF state preset by A1FT.

Exception: If Loop Break (LB) alarm or sensor Break (SENB) alarm is configured for A1FN, the alarm 1 will be switched to ON state independent of the setting of A1FT. If Dwell Timer (TIMR) is configured for A1FN, the alarm 1 will not perform failure transfer.

Alarm 2 Failure Transfer is activated as the controller enters failure mode. Thereafter the alarm 2 will transfer to the ON or OFF state preset by A2FT.

Exception: If Loop Break (LB) alarm or sensor Break (SENB) alarm is configured for A2FN, the alarm 2 will be switched to ON state independent of the setting of A2FT. If Dwell Timer (TIMR) is configured for A2FN, the alarm 2 will not perform failure transfer.

Failure Mode Occurs as :

1. SB1E
2. SB2E
3. ADER

Failure Transfer of output 1 and output 2 occurs as :

1. Power start (within 2.5 seconds)
2. Failure mode is activated
3. Manual mode is activated
4. Calibration mode is activated

Failure Transfer of alarm 1 and alarm 2 occurs as :

1. Failure mode is activated

Failure Transfer Setup :

1. O1FT
2. O2FT
3. A1FT
4. A2FT

3-18 Bumpless Transfer

The bumpless transfer function is available for output 1 and output 2 (provided that OUT2 is configured as COOL).

Bumpless Transfer is enabled by selecting BPLS for O1FT and/or O2FT and activated as one of the following cases occurs :

1. Power starts (within 2.5 seconds).
2. The controller enters the failure mode. See section 3-17 for failure mode descriptions.
3. The controller enters the manual mode. See section 3-23 for manual mode descriptions.
4. The controller enters the calibration mode. See chapter 6 for calibration mode descriptions.

As the bumpless transfer is activated, the controller will transfer to open-loop control and uses the previous averaging value of MV1 and MV2 to continue control.

Bumpless Transfer Setup :

1. O1FT = BPLS
2. O2FT = BPLS

Bumpless Transfer Occurs as :

1. Power Starts (within 2.5 seconds)
2. Failure mode is activated
3. Manual mode is activated
4. Calibration mode is activated

Without Bumpless Transfer

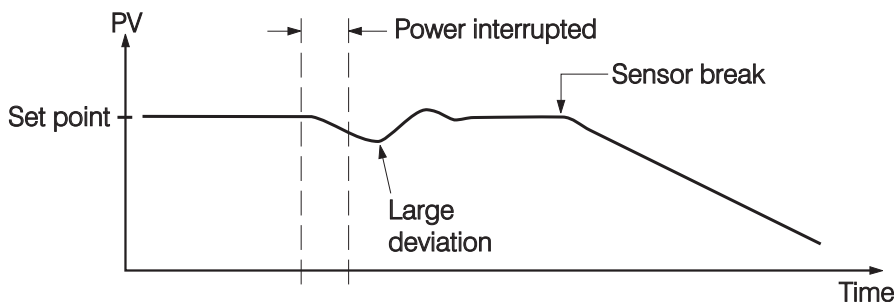
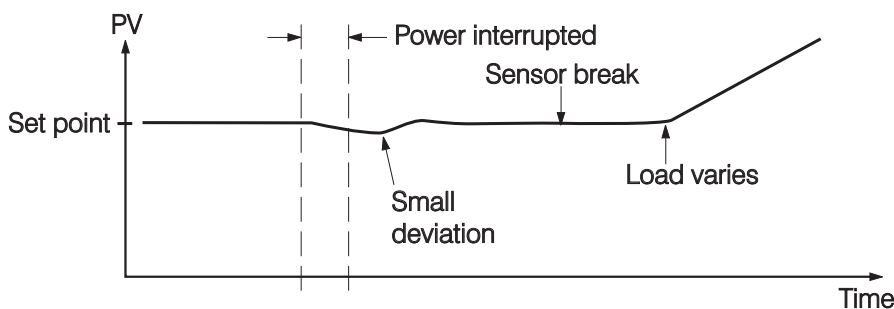

Figure 3.21 Benefits of Bumpless Transfer

Since the hardware and software need time to be initialized, the control is abnormal as the power is recovered and results in a large disturbance to the process. During the sensor breaks, the process loses power.

With Bumpless Transfer



After bumpless transfer configured, the correct control variable is applied immediately as the power is recovered, the disturbance is small. During the sensor breaks, the controller continues to control by using its previous value. If the load doesn't change, the process will remain stable. Thereafter, once the load changes, the process may run away. Therefore, you should not rely on a bumpless transfer for a longer time. For fail safe reason, an additional alarm should be used to announce the operator when the system fails. For example, a Sensor Break Alarm, if configured, will switch to failure state and announces the operator to use manual control or take a proper security action when the system enters failure mode.

Warning :After system fails, never depend on bumpless transfer for a long time, otherwise it might cause a problem to the system to run away.

3-19 Self – tuning

The Self-tuning which is designed by using an **innovative algorithm** provides an alternative option for tuning the controller. It is activated as soon as SELF is selected with YES. When Self-tuning is working, the controller will change its working PID values and compares the process behavior with previous cycle. If the new PID values achieve a better control, then changing the next PID values in the same direction, otherwise, changing the next PID values in reverse direction. When an optimal condition is obtained, the optimal PID values will be stored in PB1, TI1, TD1 or PB2, TI2, TD2 which is determined by Event Input conditions. See **Section 4-1**. When Self-tuning is completed, the value of SELF will be changed from YES to NONE to disable self-tuning function.

When the Self-tuning is enabled, the control variables are tuned slowly so that the disturbance to the process is less than auto-tuning. Usually, the Self-tuning will perform successfully with no need to apply additional auto-tuning.

Exceptions: The Self-tuning will be disabled as soon as one of the following conditions occurs:

1. SELF is selected with NONE.
2. The controller is used for on-off control, that is $PB=0$.
3. The controller is used for manual reset, that is $TI=0$.
4. The controller is under loop break condition.
5. The controller is under failure mode (e.g. sensor break).
6. The controller is under manual control mode.
7. The controller is under sleep mode.
8. The controller is being calibrated.

If the self-tuning is enabled, the auto-tuning can still be used any time. The self-tuning will use the auto-tuning results for its initial values.

Benefits of Self-tuning:

1. Unlike auto-tuning, Self-tuning will produce less disturbance to the process.
2. Unlike auto-tuning, Self-tuning doesn't change control mode during tuning period. It always performs PID control.
3. Changing set point during Self-tuning is allowable. Hence, Self-tuning can be used for ramping set point control as well as remote set point control where the set point is changed from time to time.

Operation:

The parameter SELF is contained in setup menu. Refer to **Section 1-5** to obtain SELF for initiating a self-tuning.

Self-tune Menu

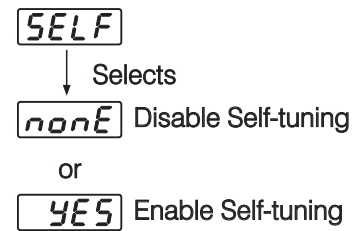

Default

SELF=NONE

Benefits of Self-tune:

1. Less disturbance to the process.
2. Perform PID control during tuning period.
3. Available for ramping set point control and remote set point control.

3-20 Auto – tuning







The auto-tuning process is performed at set point. The process will oscillate around the set point during tuning process. Set a set point to a lower value if overshooting beyond the normal process value is likely to cause damage.

The auto-tuning is applied in cases of :

- * Initial setup for a new process
- * The set point is changed substantially from the previous auto-tuning value
- * The control result is unsatisfactory

Operation :

1. The system has been installed normally.
2. Use the default values for PID before tuning.
The default values are : $PB1 = PB2 = 18.0^{\circ}F$
 $TI1 = TI2 = 100$ sec, $TD1 = TD2 = 25.0$ sec, Of course, you can use other reasonable values for PID before tuning according to your previous experiences. But don't use a zero value for PB1 and TI1 or PB2 and TI2, otherwise, the auto-tuning program will be disabled.
3. Set the set point to a normal operating value or a lower value if overshooting beyond the normal process value is likely to cause damage.
4. Press   until  appears on the display.
5. Press  for at least 3 seconds. The upper display will begin to flash and the auto-tuning procedure is beginning.

NOTE :

Any of the ramping function, remote set point or pump function, if used, will be disabled once auto-tuning is proceeding.

Procedures:

The auto-tuning can be applied either as the process is warming up (Cold Start) or as the process has been in steady state (Warm Start). See Figure 3.22.

If the auto-tuning begins apart from the set point (Cold Start), the unit enters **Warm-up cycle**. As the process reaches the set point value, the unit enters **waiting cycle**. The waiting cycle elapses a double integral time (TI1 or TI2, dependent on the selection, see **Section 4.1**) then it enters a **learning cycle**. The double integral time is introduced to allow the process to reach a stable state. Before learning cycle, the unit performs **pre-tune** function with a PID control. While in learning cycle the unit performs **post-tune** function with an ON-OFF control. Learning cycle is used to test the characteristics of the process. The data are measured and used to determine the optimal PID values. At the end of the two successive ON-OFF cycles the PID values are obtained and automatically stored in the nonvolatile memory.

After the auto-tuning procedures are completed, the process display will cease to flash and the unit revert to PID control by using its new PID values.

During pre-tune stage the PID values will be modified if any unstable phenomenon which is caused by incorrect PID values is detected. Without pre-tune stage, like other conventional controller, the tuning result will be strongly related to the time when the auto-tuning is applied. Hence different values will be obtained every time as auto-tuning is completed without pre-tune. It is particularly true when the auto-tuning are applied by using cold start and warm start.

Applicable Conditions :

$PB1 \neq 0$, $TI1 \neq 0$ if $PB1, TI1, TD1$ assigned

$PB2 \neq 0$, $TI2 \neq 0$, if $PB2, TI2, TD2$ assigned

Pre-tune Function Advantage:

Consistent tuning results can be obtained

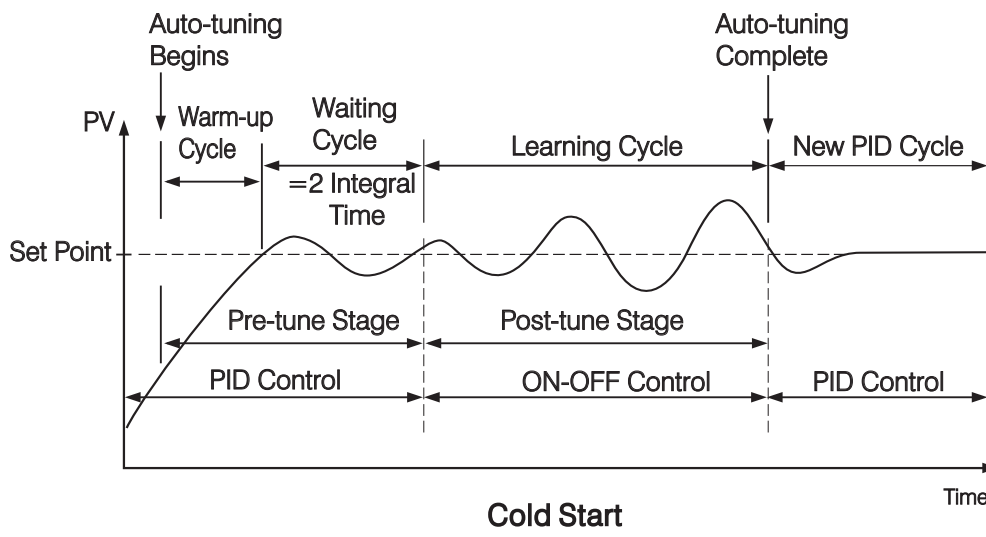
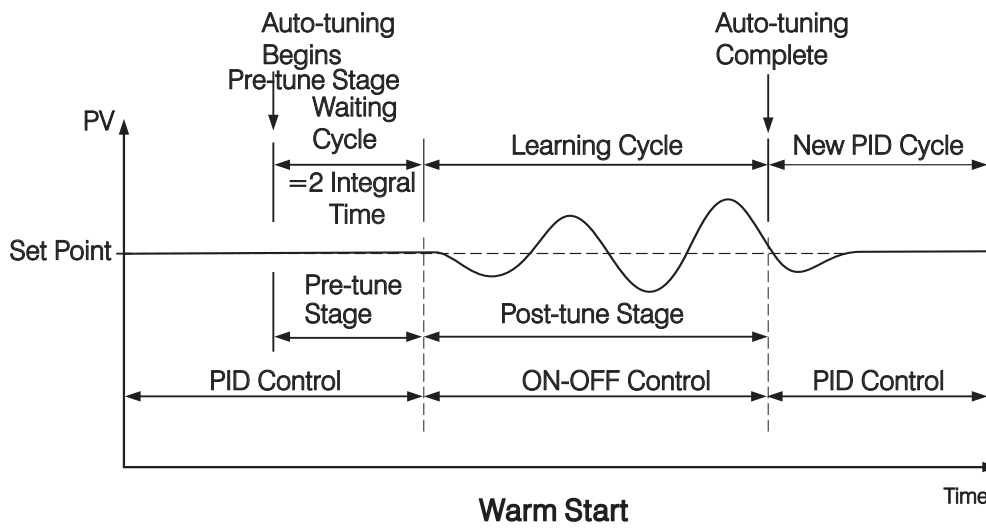

Figure 3.22
Auto-tuning Procedure



If the auto-tuning begins near the set point (warm start), the unit passes the warm-up cycle and enters the waiting cycle. Afterward the procedures are same as that described for cold start.

ATER Auto-Tuning Error

If auto-tuning fails an ATER message will appear on the upper display in cases of :

ATER Auto-Tuning Error

- If PB exceeds 9000 (9000 PU, 900.0 °F or 500.0 °C).
- or if TI exceeds 1000 seconds.
- or if set point is changed during auto-tuning procedure.
- or if event input state is changed so that set point value is changed.

Solutions to **ATER**

1. Try auto-tuning once again.
2. Don't change set point value during auto-tuning procedure.
3. Don't change event input state during auto-tuning procedure.
4. Use manual tuning instead of auto-tuning. (See section 3-21).
5. Touch any key to reset **ATER** message.

3-21 Manual Tuning

In certain applications (very few) using both self-tuning and auto-tuning to tune a process may be inadequate for the control requirement, then you can try manual tuning.

Connect the controller to the process and perform the procedures according to the flow chart shown in the following diagram.

Figure 3.23
Manual Tuning
Procedure

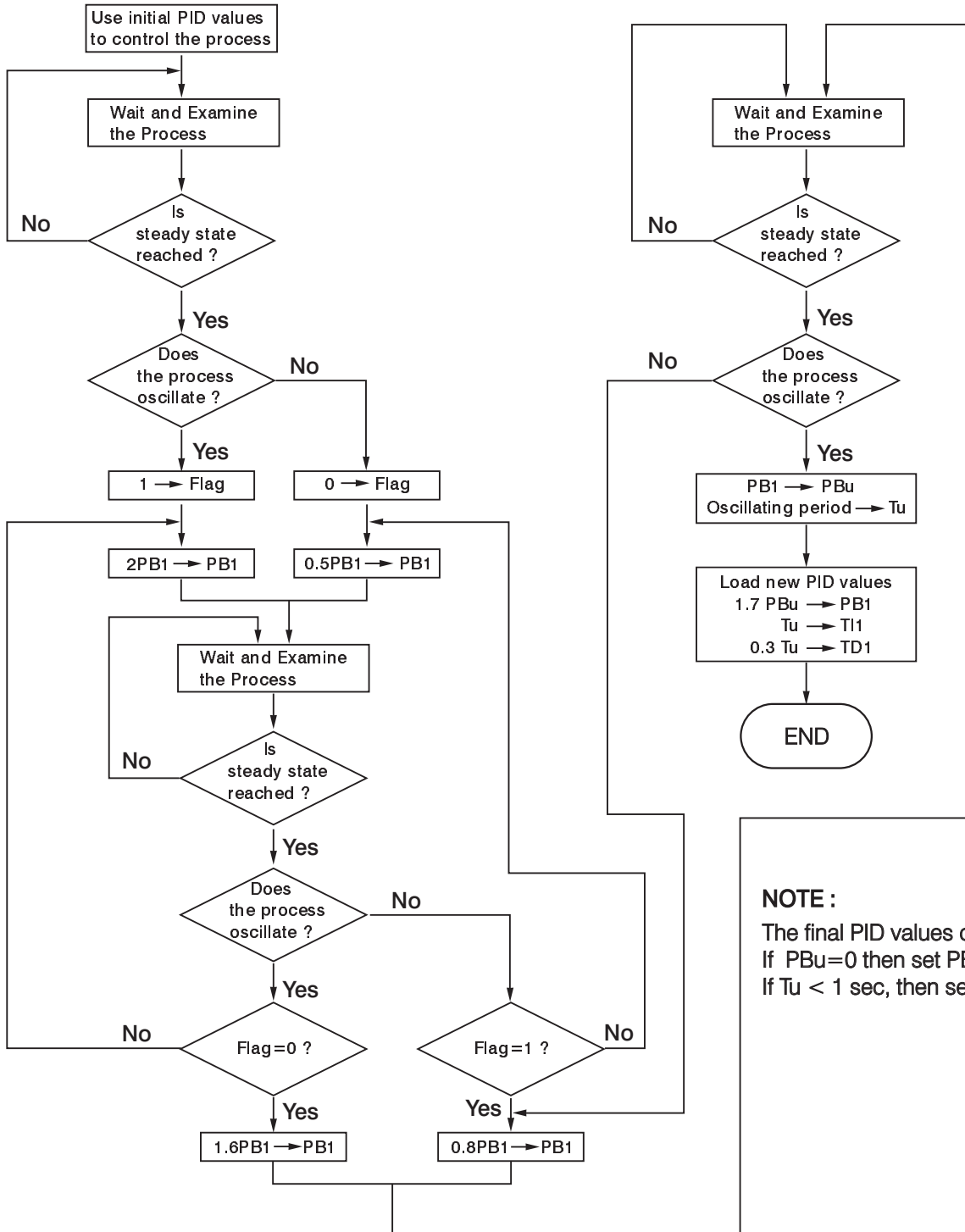

The above procedure may take a long time before reaching a new steady state since the P band was changed. This is particularly true for a slow process. So the above manual tuning procedures will take from minutes to hours to obtain optimal PID values.

The P_{Bu} is called the **Ultimate P Band** and the period of oscillation T_u is called the **Ultimate Period** in the flow chart of Figure 3.23 . When this occurs, the process is called in a **critical steady state**. Figure 3.24 shows a critical steady state occasion.

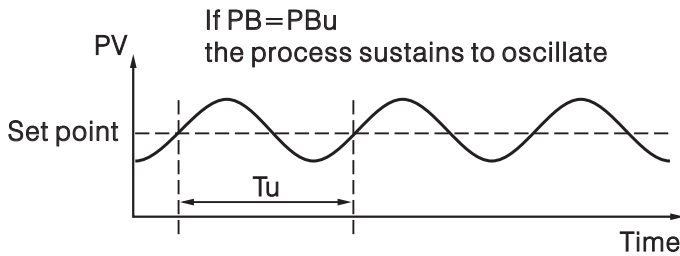

Figure 3.24 Critical Steady State

If the control performance by using above tuning is still unsatisfactory, the following rules can be applied for further adjustment of PID values :

ADJUSTMENT SEQUENCE	SYMPTOM	SOLUTION
(1) Proportional Band (P) PB1 and/or PB2	Slow Response	Decrease PB1 or PB2
	High overshoot or Oscillations	Increase PB1 or PB2
(2) Integral Time (I) TI1 and/or TI2	Slow Response	Decrease TI1 or TI2
	Instability or Oscillations	Increase TI1 or TI2
(3) Derivative Time (D) TD1 and/or TD2	Slow Response or Oscillations	Decrease TD1 or TD2
	High Overshoot	Increase TD1 or TD2

Table 3.2 PID Adjustment Guide

Figure 3.25 shows the effects of PID adjustment on process response.

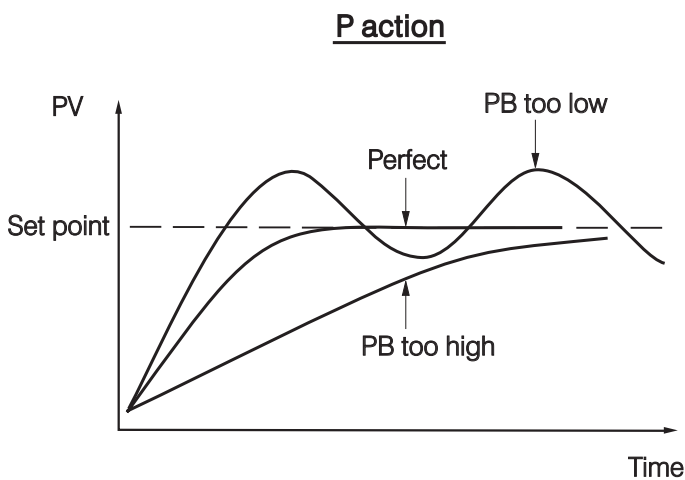

Figure 3.25 Effects of PID Adjustment

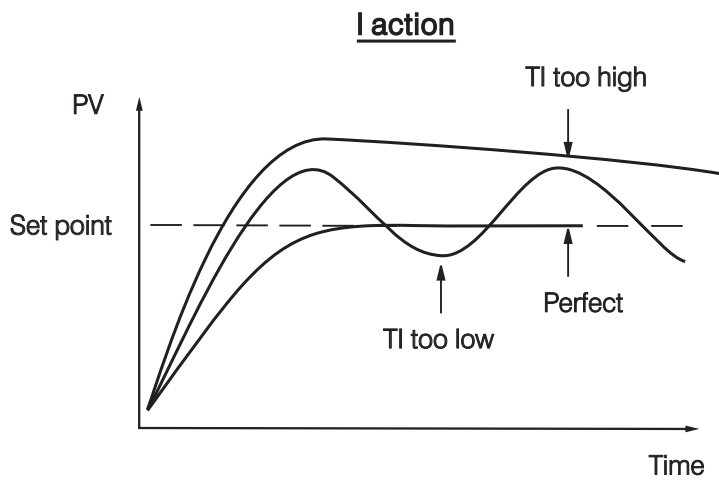
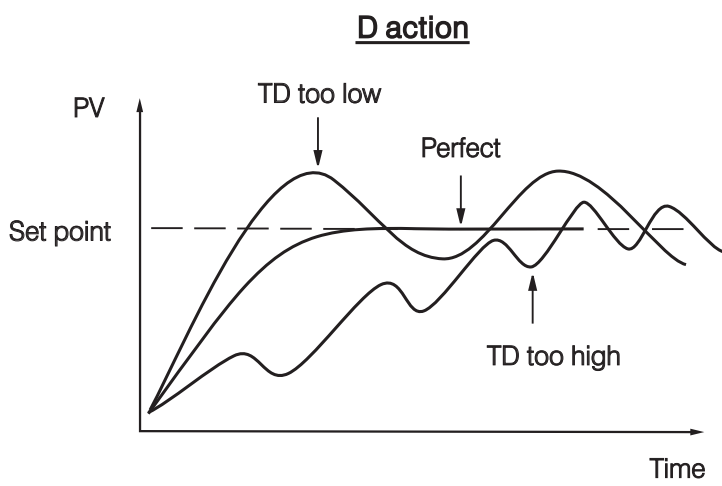
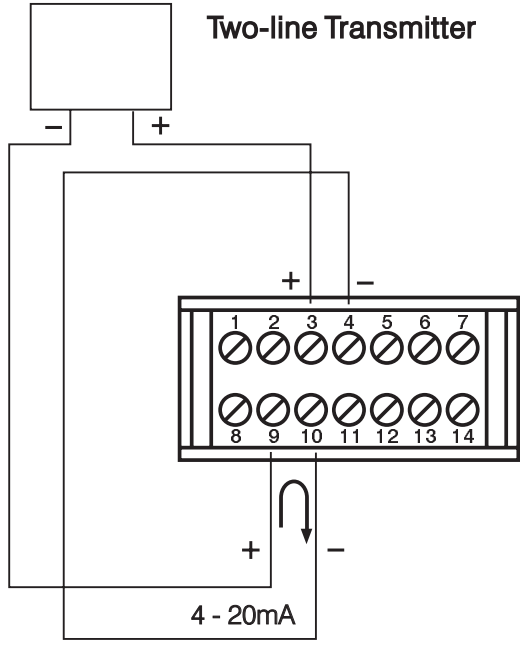

Figure 3.25 (Continued)
Effects of PID Adjustment



3-22 Signal Conditioner DC Power Supply

Three types of isolated DC power supply are available to supply an external transmitter or sensor. These are 20V rated at 25mA, 12V rated at 40 mA and 5V rated at 80 mA. The DC voltage is delivered to the output 2 terminals.



Set
OUT2= dCPS
 (DC Power Supply)

Figure 3.26
 DC Power Supply Applications

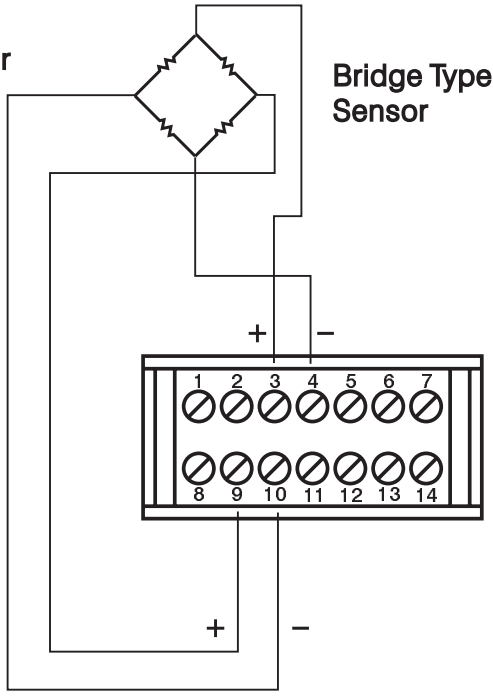
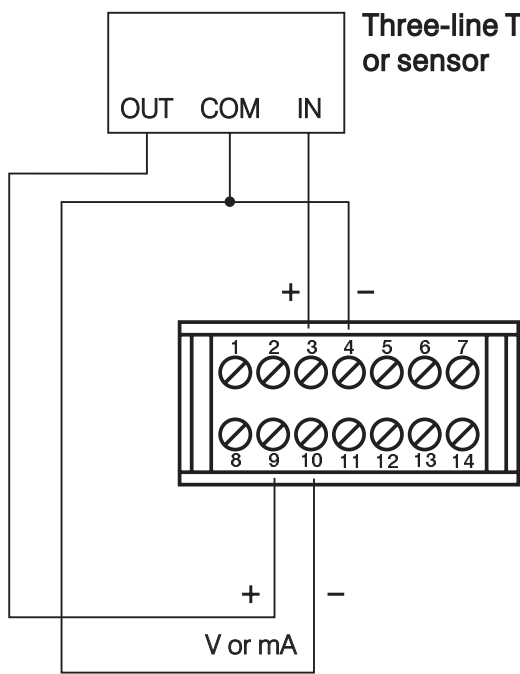

Caution:

Don't use the DC power supply beyond its rating current to avoid damage.
 Purchase a correct voltage to suit your external devices. See ordering code in section 1-2.

3-23 Manual Control

The manual control may be used for the following purposes:

- (1) To test the process characteristics to obtain a step response as well as an impulse response and use these data for tuning a controller.
- (2) To use manual control instead of a close loop control as the sensor fails or the controller's A-D converter fails. **NOTE** that a bumpless transfer can not be used for a longer time. See section 3-18.
- (3) In certain applications it is desirable to supply a process with a constant demand.

Operation:

Press   until **Hand** (Hand Control) appears on the display.

Press  for 3 seconds then the upper display will begin to flash and the lower display will show **H_ _ _**. The controller now enters the manual control mode.

Pressing  the lower display will show **C_ _ _** and **H_ _ _** alternately where **H_ _ _** indicates output 1 (or heating) control variable value MV1 and **C_ _ _** indicates output 2 (or cooling) control variable value MV2. Now you can use up-down key to adjust the percentage values for H or C.

H38.4 Means
MV1=38.4 %
for OUT1 (or Heating)



C7.63 Means
MV2=7.63 %
for OUT2 (or Cooling)

The controller performs open loop control as long as it stays in manual control mode. The H value is exported to output 1 (OUT1) and C value is exported to output 2 provided that OUT2 is performing cooling function (ie. OUT2 selects COOL).

Exception

If OUT1 is configured as ON-OFF control (ie. PB1=0 if PB1 is assigned or PB2=0 if PB2 is assigned by event input), the controller will never perform manual control mode.

Exit Manual Control

To press   keys the controller will revert to its previous operating mode (may be a failure mode or normal control mode).

3-24 Display Mode

Operation

Press several times until (Display) appears on the display. Then press to enter the display mode. You can select more parameters to view by pressing or pressing in reverse sequence . The system mode of the controller and its operation will remain unchanged.

Entering the Display Mode, the upper display will show the parameter value and the lower display will show the parameter symbol except and . shows the percentage value for output 1 and shows the percentage value for output 2 on the lower display while the upper display shows the current process value.

PVHI/PVLO show the historical extreme (maximum or minimum) values of the process on the upper display. The historical extreme values are saved in a nonvolatile memory even if it is unpowered. Press for at least 6 seconds to reset both the historical values PVHI and PVLO and begin to record new peak process values.

MV1/MV2 show the process value on the upper display and shows the percentage control value for the output 1, shows the percentage control value for the output 2.

DV shows the difference value between process and set point (ie. PV-SV). This value is used to control the output 1 and output 2.

PV1 shows the process value of input 1 on the upper display.

PV2 shows the process value of input 2 on the upper display.

PB shows the current proportional band value used for control.

TI shows the current integral time used for control.

TD shows the current derivative time used for control.

Since the controller is performing FUZZY control the values of PB, TI, and TD may change from time to time.

CJCT shows the temperature at the cold junction, measured in °C independent of the unit used.

PVR Shows the changing rate of the process in °C (°F or PU) per minute. It may be negative if the process is going down.

PVRH/PVRL The maximum and minimum changing rate of the process since power up, are measured in °C (°F or PU) per minute. PVRH is a positive value while PVRL is a negative value.

NOTE

The controller will never revert to its PV/SV display from Display Mode unless you press the keys.

PVHI

PVLO

MV1

MV2

DV

PV1

PV2

PB

TI

TD

CJCT

PVR

PVRH

PVRL

3-25 Heater Current Monitoring

A current transformer, CT94-1, should be equipped to measure the heater current. Select CT for IN2. The input 2 signal conditioner measures the heater current during the heater is powered and the current value will remain unchanged during the heater is unpowered. The PV2 will indicate the heater current. About how to read PV2 value, please refer to **section 3-24**.

NOTES

If the heater to be measured is controlled by output 1, then CYC1 should select 1 second or longer and O1TY should use RELY, SSRD or SSR. Similarly, if the heater to be measured is controlled by output 2, then CYC2 should select 1 second or longer and O2TY should use RELY, SSRD or SSR to provide an adequate time for A to D converter to measure the signal. Since CT94-1 can detect a full-wave AC current only, a DC or half-wave AC can't be measured.

Accessory Installed:
CT94-1

Setup

IN2=CT
O1TY or O2TY=RELY, SSRD or SSR
CYC1 or CYC2 \geq 1 sec







Limitations

1. Linear output type can't be used.
2. CYC1 (or CYC2) should select 1 second or longer to detect heater current reliably.
3. Only full-wave AC current can be detected.

3-26 Reload Default Values

The default values listed in Table 1.4 are stored in the memory as the product leaves the factory. In certain occasions it is desirable to retain these values after the parameter values have been changed. Here is a convenient tool to reload the default values.

Operation

Press   several times until . Then press . The upper display will show . Use up-down key to select 0 to 1. If °C unit is required, select 0 for FILE and if °F unit is required, select 1 for FILE. Then Press  for at least 3 seconds. The display will flash a moment and the default values are reloaded.

FILE 0
°C Default File

FILE 1
°F Default File

CAUTION

The procedures mentioned above will change the previous setup data. Before doing so, make sure that it is really required.

Chapter 4 Programming the Full Function

4-1 Event Input

Refer to Section 2-10 for wiring an event input.

The Event input accepts a digital type signal. **Two** types of signal : (1) relay or switch contacts and (2) open collector pull low, can be used to switch the event input.

One of ten functions can be chosen by using $\boxed{E,Fn}$ (EIFN) contained in setup menu.

NONE : Event input no function

If chosen, the event input function is disabled. The controller will use PB1, TI1 and TD1 for PID control and SP1 (or other values determined by SPMD) for the set point.

SP2: If chosen, the SP2 will replace the role of SP1 for control.

PID2: If chosen, the second PID set PB2, TI2 and TD2 will be used to replace PB1, TI1 and TD1 for control.

SPP2: If chosen, the SP2, PB2, TI2 and TD2 will replace SP1, PB1, TI1 and TD1 for control.

NOTE: If the second PID set is chosen during **Auto-tuning** and/or **Self-tuning** procedures, the new PID values will be stored in PB2, TI2 and TD2.

RS.A1: Reset Alarm 1 as the event input is activated. However, if alarm 1 condition is still existent, the alarm 1 will be retriggered again while the event input is released.

RS.A2: Reset Alarm 2 as the event input is activated. However, if alarm 2 condition is still existent, the alarm 2 will be retriggered again while the event input is released.

R.A1.2: Reset both Alarm 1 and Alarm 2 as the event input is activated. However, if the alarm 1 and/or alarm 2 are still existent, the alarm 1 and/or alarm 2 will be triggered again while the event input is released.

The RS.A1, RS.A2 and R.A1.2 are particularly suitable to be used for a Latching and/or Latching/Holding alarms.

D.O1: Disable Output 1 as the event input is activated. The output 1 control variable MV1 is cleared to zero.

D.O2: Disable Output 2 as the event input is activated. The output 2 control variable MV2 is cleared to zero.

D.O1.2: Disable both Output 1 and Output 2 by clearing MV1 and MV2 values as soon as the event input is activated.

When any of D.O1, D.O2 or D.O1.2 is selected for EIFN, the output 1 and/or output 2 will revert to their normal conditions as soon as the event input is released.

LOCK: All parameters are locked to prevent from being changed. See **Section 4-13** for more details.

Terminals:

⑪ Event input +

⑩ Event input -

EIFN

0 NONE

1 SP2

2 PID2

3 SPP2

4 RS.A1

5 RS.A2

6 R.A1.2

7 D.O1

8 D.O2

9 D.O1.2

10 LOCK

SP2F Function: Define format of SP2 value . If SP2F in the setup menu is selected with ACTU, the event input function will use SP2 value for its second set point. If SP2F is selected with DEVI, the SP1 value will be added to SP2. The sum of SP1 and SP2 (SP1+SP2) will be used by the event input function for the second set point value. In certain applications it is desirable to move second set point value with respect to set point 1 value. The DEVI function for SP2 provides a convenient way in this case.

Modification from RS-232 to Event input:

Because of limitation of pin number, pin 11 is used for both Event input and RS-232. If you want to change function of BTC-2500 from RS-232 to event input, you **must** modify jumper J51 and J52 on CPU board by opening jumper J52 and shorting jumper J51. Refer to **Section 2-16** for the location of jumper J51/J52.

4-2 Second Set Point

In certain applications it is desirable to change the set point automatically without the need to adjust the set point. You can apply a signal to event input terminals (pin 10 and pin 11).The signal applied to event input may come from a **Timer**, a **PLC**, an **Alarm Relay**, a **Manual Switch** or other devices. Select SP2 for EIFN which is contained in setup menu.

This is available only with the case that SP1.2, MIN.R or HR.R is used for SPMD, where MIN.R and HR.R are used for the ramping function. See **Section 4-4**.

Application 1: A process is required to be heated at a higher temperature as soon as its pressure exceeds a certain limit. Set SPMD=SP1.2, EIFN=SP2 (or SPP2 if the second PID is required for the higher temperature too). The pressure gauge is switched ON as it senses a higher pressure. Connect the output contacts of the pressure gauge to the event input. SP1 is set with a normal temperature and SP2 is set with a higher temperature. Choose ACTU for SP2F.

Application 2: An oven is required to be heated at 300 °C from eight o'clock AM to six o'clock PM. After six o'clock PM it is desirable to be maintained at 80 °C. Use a programmable 24 hours cycle timer for this purpose. The timer output is used to control event input. Set SPMD=SP1.2, and EIFN=SP2 (or SPP2 if the second PID is required to be used for the second set point).

SP1 is set with 300 °C and SP2 is set with 80 °C. Choose ACTU for SP2F. After six o'clock PM the timer output is closed. The event input function will select SP2 (=80 °C) to control the process.

Refer to **Section 4-1** for more descriptions about **SP2F** function.

SP2F=Format of SP2 Value
 ACTU: SP2 is an actual value
 DEVI: SP2 is a deviation value

Apply Signal To

- ⑪ Event input +
- ⑩ Event input -

Setup

EIFN choose SP2 or SPP2

Availability

SPMD choose

- SP1.2
- or MIN.R
- or HR.R

Format of SP2 Value

SP2F choose

- ACTU Actual Value
- or DEVI Deviation Value

4-3 Second PID Set

In certain applications the process characteristics is strongly related to its process value. The BTC-2500 provides two set of PID values. When the process is changed to different set point, the PID values can be switched to another set to achieve an optimum condition.

Auto-tuning Second PID

The optimal PID values for a process may vary with its process value and set point. Hence if a process is used for a wide range of set point, dual PID values are necessary to optimize the control performance. If the first PID set is selected (event input is not applied) during auto-tuning procedure, the PID values will be stored in PB1, TI1 and TD1. Similarly, if the second PID set is selected (event input is applied while PID2 or SPP2 is selected for EIFN) during auto-tuning, the PID values will be stored in PB2, TI2 and TD2 as soon as auto-tuning is completed.

Application 1: Programmed by Set Point

Choose **SPP2** for **EIFN** then both set point and PID values will be switched to another set simultaneously. The signal applied to event input may come from a Timer, a PLC, an Alarm Relay, a Manual Switch or other devices.

Application 2: Programmed by Process Value

If the process value exceeds a certain limit, 500 °C for example, it is desirable to use another PID values to optimize the control performance. You can use a process high alarm to detect the limit of the process value. Choose PV1H for A1FN, A1MD selects NORM, adjust A1SP to be equal to 500 °C, and choose PID2 for EIFN. If the temperature is higher than 500 °C, then alarm 1 is activated. The alarm 1 output is connected to event input, the PID values will change from PB1, TI1 and TD1 to PB2, TI2 and TD2.

Refer to Section 5-9 for more details.

Apply Signal To

- ⑪ Event input +
- ⑩ Event input -

Setup

EIFN choose PID2 or SPP2

EIFN= SPP2

EIFN= PID2

Alarm output Controls the Event input

See Section 5-9

4-4 Ramp & Dwell

Ramp

The ramping function is performed during power up as well as any time the set point is changed. Choose MINR or HRR for SPMD, the unit will perform the ramping function. The ramp rate is programmed by using RAMP which is contained in user menu.

Example without Dwell Timer

Select MINR for SPMD, IN1U selects °C, DP1 selects 1-DP, Set RAMP=10.0. SP1 is set to 200°C initially, and changed to 100°C after 30 minutes since power up. The starting temperature is 30°C. After power up the process is running like the curve shown below:

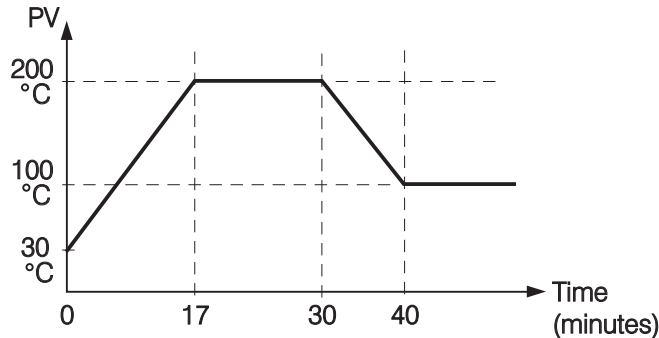

Note: When the ramp function is used, the lower display will show the current ramping value. However it will revert to show the set point value as soon as the up or down key is touched for adjustment. The ramping value is initiated to process value either power up or RAMP and /or set point are changed. Setting RAMP to zero means no ramp function at all.

Dwell

The Dwell timer can be used separately or accompanied with a Ramp. If A1FN selects TIMR, the alarm 1 will act as a dwell timer. Similarly, alarm 2 will act as a dwell timer if A2FN selects TIMR. The timer is programmed by using TIME which is contained in user menu. The Timer starts to count as soon as the process reaches its set point, and triggers an alarm as time out. Here is an example.

Example without Ramp

Select TIMR for A1FN, IN1U selects °F, DP1 selects NODP, Set TIME=30.0. SP1 is set to 400°F initially, and corrected to 200°F before the process reaches 200°F. As the process reaches set point (ie. 200°F) the timer starts to count. The TIME value can still be corrected without disturbing the Timer before time out. The TIME is changed to 40.0 after 28 minutes since the process reached its set point. The behavior of process value and alarm 1 are shown below.

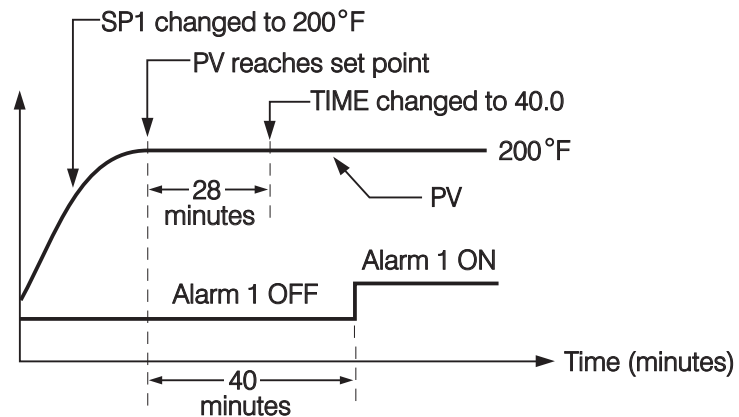

SPMD Choose

MINR Unit / minute
or HRR Unit / hour

Adjust

RAMP

Figure 4.1 RAMP Function

A1FN or A2FN Choose

TIMER

Adjust

TIME

Figure 4.2 Dwell Timer

Once the timer output was energized it will remain unchanged until power down or an event input programmed for resetting alarm is applied.

Note: The TIMR can't be chosen for both A1FN and A2FN simultaneously, otherwise an **Er07** error code will produce.

Er07 Error Code.

Ramp & Dwell

A ramp may be accompanied with a dwell timer to control the process. Here is an example.

Example with Ramp & Dwell

Select HRR for SPMD, IN1U selects PU, DP1 select 2-DP, Set RAMP=60.00 A2FN selects TIMR, Set TIME=20.0 As power is applied the process value starts from 0.00 and set SP1=30.00, SP2=40.00. The timer output is used to control event input

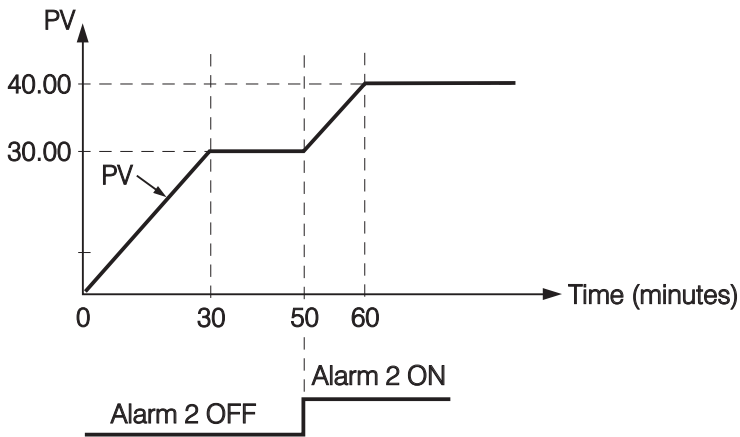

Figure 4.3 Ramp Accompanied with a Dwell Timer

4-5 Remote Set Point

SPMD selecting PV1 or PV2 will enable the BTC-2500 to accept a remote set point signal. If PV1 is selected for SPMD, the remote set point signal is sent to Input 1, and Input 2 is used for process signal input. If PV2 is selected for SPMD, the remote set point signal is sent to Input 2, and Input 1 is used for process signal. To achieve this, set the following parameters in the Setup menu.

Case 1: Use Input 2 to accept remote set point

FUNC=FULL

IN2, IN2U, DP2, IN2L, IN2H, are set according to remote signal.

PVMD=PV1

IN1, IN1U, DP1, are set according to the process signal

IN1L, IN1H if available, are set according to the process signal

SPMD= PV2

Case 2: Use Input 1 to accept remote set point

FUNC=FULL

IN1, IN1U, DP1, IN1L, IN1H, are set according to remote signal.

PVMD=PV2

IN2, IN2U, DP2, are set according to the process signal

IN2L, IN2H if available, are set according to the process signal

SPMD= PV1

Note: If PV1 are chosen for both SPMD and PVMD, an **Er01** Error Code will appear. If PV2 are chosen for both SPMD and PVMD, an **Er02** Error Code will appear. You should not use these cases, otherwise, the BTC-2500 will not control properly.

Setup

FUNC=FULL

SPMD=PV2, PVMD=PV1

or SPMD=PV1, PVMD=PV2

Error Message

Er01

Er02

4-6 Differential Control

In certain applications it is desirable to control a second process such that its process value always deviates from the first process with a constant value. To achieve this, set the following parameter in the Setup menu.

FUNC=FULL

IN1,IN1L,IN1H are set according to input 1 signal

IN2,IN2L,IN2H are set according to input 2 signal

IN1U, DP1, IN2U, DP2, are set according to input 1 and input 2 signal

PVMD=P1-2 or P2-1

SPMD=SP1.2

The response of PV2 will be parallel to PV1 as shown in the following diagram

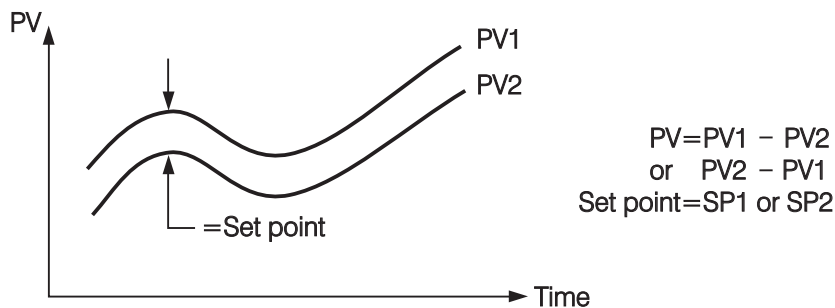

Setup

PVMD=P1-2

or PVMD=P2-1

SPMD=SP1.2

Figure 4.4
Relation between PV1 and PV2
for a Differential Control

The PV display will indicate PV1-PV2 value if P1-2 is chosen for PVMD, or PV2-PV1 value if P2-1 is chosen for PVMD. If you need PV1 or PV2 to be displayed instead of PV, you can use the Display Mode to select PV1 or PV2 to be viewed. See Section 3-24.

Error Messages

If PVMD selects P1-2 or P2-1, while SPMD selects PV1 or PV2, an **Er03** Error Code will appear.

In this case the signals used for input 1 and input 2 should be the same unit and same decimal point, that is, IN1U=IN2U, DP1=DP2, otherwise **Er05** Error Code will appear.

Error Message

Er03



Er05

4-7 Output Power Limits

In certain system the heater (or cooler) is over-designed such that the process is too heavily heated or cooled. To avoid an excessive overshoot and/or undershoot you can use the Power Limit function.

Output 1 power limit PL1 is contained in User Menu. If output 2 is not used for cooling (that is COOL is not selected for OUT2), then PL2 is **hidden**. If the controller is used for ON-OFF control, then both PL1 and PL2 are **hidden**.

Operation:

Press  for 3 seconds, then press  several times to reach PL1 and PL2. The PL1 and PL2 are adjusted by using up-down keys with range 0 - 100%.

Example:

OUT2=COOL, PB1=10.0 °C, CPB=50, PL1=50, PL2=80
 The output 1 and output 2 will act as following curves:

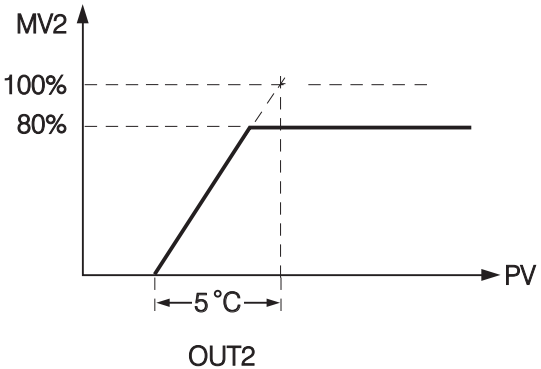
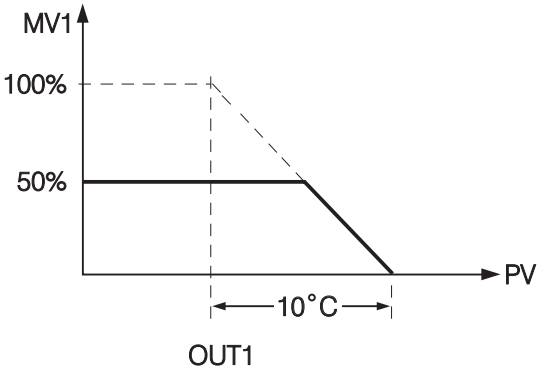

Menu
 PL1
 PL2

Figure 4.5
 Power Limit Function

NOTE:

The adjusting range of MV1 (H) and MV2 (C) for manual control and/or failure transfer are not limited by PL1 and PL2.

4-8 Data Communication

Two types of interface are available for Data Communication. These are **RS-485** and **RS-232** interface. Since RS-485 uses a differential architecture to drive and sense signal instead of a single ended architecture which is used for RS-232, RS-485 is less sensitive to the noise and suitable for a longer distance communication. RS-485 can communicate without error over 1 km distance while RS-232 is not recommended for a distance over 20 meters.

Using a PC for data communication is the most economic way. The signal is transmitted and received through the PC communication Port (generally RS-232). Since a standard PC can't support RS-485 port, a network adaptor (such as **SNA10A, SNA10B**) has to be used to convert RS-485 to RS-232 for a PC if RS-485 is required for the data communication. But there is no need to be sad. Many RS-485 units (up to 247 units) can be connected to one RS-232 port; therefore a PC with 4 comm ports can communicate with 988 units. It is quite economic.

Setup

Enters the setup menu.

Select FULL (Full function) for FUNC.

Select 485 for COMM if RS-485 is required, or 232 if RS-232 is required. Select RTU (ie. Modbus protocol RTU mode) for PROT. Set individual address as for those units which are connected to the same port.

Set the Baud Rate (BAUD), Data Bit (DATA), Parity Bit (PARI) and Stop Bit (STOP) such that these values are accordant with PC setup conditions.

NOTE: If the BTC-2500 is configured for RS-232 communication, the EI (Event Input) and input 2 are disconnected internally. The unit can no longer perform event input function (EIFN) and other input 2 functions.

When you insert a RS-232 module (CM94-2) to the connectors on CPU board (C250), you also need to modify the jumper J51 and J52 according to **Section 2-16**.

If you use a conventional 9-pin RS-232 cable instead of CC94-1, the cable should be modified for proper operation of RS-232 communication according to **Section 2-16**.

RS-485 Benefits:

Long distance
Multi-units

RS-232 Benefits:

Direct Connection to a PC

Order BTC-2500-XXXXX1
for RS-485

Order BTC-2500-XXXXX2
for RS-232

RS-485 Setup

FUNC=FULL

COMM=485

PROT=RTU

ADDR=Address

BAUD=Baud Rate

DATA=Data Bit Count

PARI=Parity Bit

STOP=Stop Bit Count

RS-485 Terminals

⑫ TX1

⑬ TX2

RS-232 Setup

FUNC=FULL

COMM=232

PROT=RTU

ADDR=Address

BAUD=Baud Rate

DATA=Data Bit Count

PARI=Parity Bit

STOP=Stop Bit Count

RS-232 Terminals

⑫ TX1

⑬ TX2

⑪ COM

4-9 Analog Retransmission

The Analog Retransmission is available for model number BTC-2500-XXXXXN Where N=3,4 or 5. See Ordering Code in section 1-2.

Setup

Select FULL for FUNC in the setup menu.

COMM selects a correct output signal which should be accordant with the retransmission option used. Five types of retransmission output are available. These are : 4-20 mA, 0-20mA, 0-5V, 1-5V and 0-10V. There are 8 types of parameters that can be retransmitted according to the Analog Function (AOFN) selected. These are : PV1, PV2, PV1 – PV2, PV2 – PV1, SV, MV1, MV2 and PV – SV. Refer to Table 1.4 for a complete description. AOLO selects a value corresponding to output zero and AOHI selects a value corresponding to output SPAN.

How to Determine Output Signal:

AOLO and AOHI are set to map to output signal LOW SL (e.g. 4mA) and output signal High SH (e.g. 20mA) respectively. The analog output signal AOS corresponding to an arbitrary value of parameter AOV is determined by the following curve.

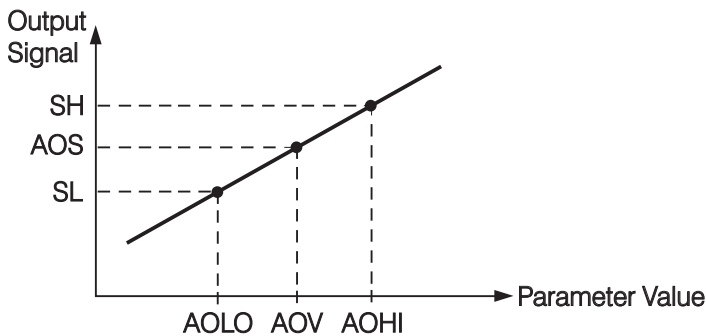

$$\text{Formula: } AOS = SL + (AOV - AOLO) \frac{SH - SL}{AOHI - AOLO}$$

$$AOV = AOLO + (AOS - SL) \frac{AOHI - AOLO}{SH - SL}$$

Notes:

The setup values used for AOHI and AOLO must not be equal, otherwise, incorrect value will happen. However, AOHI can be set either higher or lower than AOLO. If AOHI is set higher than AOLO it could result in a direct conversion. If AOHI is set lower than AOLO it could result in a reverse conversion.

Example

A control uses 4-20 mA analog output to retransmit difference value between input 1 and input 2 (PV1 – PV2). It is required that if the difference value is 100, 4mA will be exported, and if the difference value is 100, 20mA will be exported. Make the following Setup for BTC-2500:
IN1U=PU, DP1=NODP, IN2U=PU, DP2=NODP, FUNC=FULL, COMM=4-20, AOFN=P1-2, AOLO=-100, AOHI=100

Setup Menu

FUNC FUNC

COMM COMM

AOFN AOFN

AOLO AOLO

AOHI AOHI

Terminals

⑫ AO+

⑬ AO-

Figure 4.6
Conversion Curve
for Retransmission

NOTES

AOHI ≠ AOLO

AOHI > AOLO:

Direct Conversion

AOHI < AOLO:

Reverse Conversion

4-10 Digital Filter

In certain application the process value is too unstable to be read. To improve this a programmable low pass filter incorporated in the BTC-2500 can be used. This is a first order filter with time constant specified by **FILT** parameter which is contained in setup menu. The default value of **FILT** is 0.5 sec. before shipping. Adjust **FILT** to change the time constant from 0 to 60 seconds. 0 second represents no filter is applied to the input signal. The filter is characterized by the following diagram.

Menu

F, L T **FILT**

Filter is used to stabilize the process display.

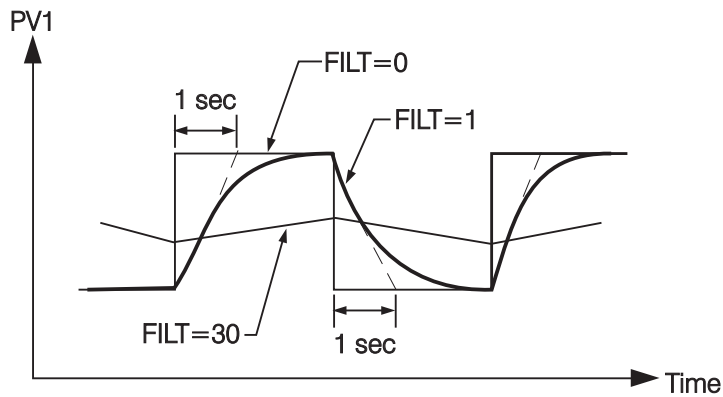

Figure 4.7
Filter Characteristics

Note

The Filter is available only for PV1, and is performed for the displayed value only. The controller is designed to use unfiltered signal for control even if Filter is applied. A lagged (filtered) signal, if used for control, may produce an unstable process.

4-11 Sleep Mode

To **Enter** Sleep Mode:

FUNC selects FULL to provide full function.



SLEP selects YES to enable the sleep mode.

Press   for 3 seconds, the unit will enter its sleep mode.

During sleep mode:

- (1) Shut off all display except a decimal point which is lit periodically.
- (2) Shut off all outputs and alarms.

To **Exit** Sleep Mode:

- (1) Press   to leave the sleep mode.
- (2) Disconnect the power.

Sleep Function can be used to replace a **power switch** to reduce the system cost.

Default: SLEP=NONE, Sleep mode is disabled.

Note: If the Sleep mode is not required by your system, the SLEP should select NONE to disable sleep mode against undesirable occurrence.

Sleep Mode Features:

Shut off display
Shut off outputs
Green Power
Replace Power Switch

Setup Menu

FUNC=FULL
SLEP=YES

4-12 Pump Control

Pump Control function is one of the unique features of BTC-2500. Using this function the pressure in a process can be controlled excellently. The pressure in a process is commonly generated by a pump driven by a variable speed motor. The complete system has the following **characteristics** which affects the control behavior: **1**, The system is very noisy. **2**, The pressure is changed very rapidly. **3**, The pump characteristics is ultra nonlinear with respect to its speed. **4**, The pump can't generate any more pressure as its speed is lower than half of its rating speed. **5**, An ordinary pump may slowly lose the pressure even if the valves are completely closed.

Obviously a conventional controller can't fulfill the conditions mentioned above. Only the superior noise rejection capability in addition to the fast sampling rate owned by BTC-2500 can realize such application. To achieve this, set the following parameters in the setup menu:

```
FUNC=FULL
EIFN=NONE
PVMD=PV1
FILT=0.5
SELF=NONE
SPMD=PUMP
SP2F=DEVI
```

and program the following parameters in the user menu:

```
REFC= Reference constant
SP2= A negative value is added to SP1 to obtain the set point for idle state
```

Since the pump can't produce any more pressure at lower speed, the pump may not stop running even if the pressure has reached the set point. If this happens, the pump will be over worn out and waste additional power. To avoid this, the BTC-2500 provides a **Reference Constant REFC** in the user menu. If PUMP is selected for SPMD, the controller will periodically test the process by using this reference constant after the pressure has reached its set point. If the test shows that the pressure is still consumed by the process, the controller will continue to supply appropriate power to the pump. If the test shows that the pressure is not consumed by the process, the controller will gradually decrease the power to the pump until the pump stops running. As this happens, the controller enters **idle state**. The idle state will use a lower set point which is obtained by adding SP2 to SP1 until the pressure falls below this set point. The idle state is provided for the purpose of preventing the pump from been restarted too frequently. The value of SP2 should be **negative** to ensure a correct function.

The pump functions are summarized as follows:

1. If the process is demanding material (ie. lose pressure), the controller will precisely control the pressure at set point.
2. If the process no longer consumes material, the controller will shut off the pump as long as possible.
3. The controller will restart the pump to control the pressure at set point as soon as the material is demanded again while the pressure falls below a predetermined value (ie. $SP1 + SP2$).

**PUMP: A Cost Effective
yet Perfect Solution**

Key menu

```
SPMD
SP2F
REFC
SP2
```

Pump Control Features:

1. Minimum oscillation of pressure
2. Rapidly stabilized
3. Guaranteed pump stop
4. Programmable pump stopping interval

Programming Guide:

1. Perform auto-tuning to the system under such condition that the material (ie. pressure) is exhausted at typical rate. A typical value for PB1 is about 10 Kg/cm^2 , T11 is about 1 second, TD1 is about 0.2 second.
2. If the process oscillates around set point after auto-tuning, then increase PB1 until the process can be stabilized at set point. The typical value of PB1 is about half to two times of the range of pressure sensor.
3. Increase FILT (Filter) can further reduce oscillation amplitude. But a value of FILT higher than 5 (seconds) is not recommended. A typical value for FILT is 0.5 or 1 .
4. Close the valves and examine that if the controller can shut off the pump each time. The value of REFC is adjusted as small as possible so that the controller can shut off the pump each time when all the valves are closed. A typical value for REFC is between 3 and 5.
5. An ordinary pump may slowly lose the pressure even if the valves are completely closed. Adjust SP2 according to the rule that a more negative value of SP2 will allow the pump to be shut off for a longer time as the valves are closed. A typical value for SP2 is about -0.50 Kg/cm^2 .

An **Example** is given in **section 5-1** for pump control.

4-13 Remote Lockout

The parameters can be locked to prevent from being changed by using either **Hardware Lockout** (see **Section 1-3**) or **Remote Lockout** or **both**. If you need the parameters to be locked by using an external switch (remote lockout function), then connect a switch to terminals 10 and 11 (see **Section 2-10**), and choose **LOCK** for **EIFN** (see **Section 4-1**).

If remote lockout is configured, all parameters will be locked as the external switch is closed. When the switch is left open, the lockout condition is determined by internal DIP switch (hardware lockout, see **Section 1-3**).

Hardware Lockout: Can be used only during initial setup.

Remote Lockout: Can be used any time.

Remote Lockout:

1. Connect external switch to terminal ⑩ and ⑪.
2. Set **LOCK** for **EIFN**
3. Lock all parameters

Chapter 5 Applications

5-1 Pump / Pressure Control

A regulated water supply system is widely used in residence, water plant, chemical plant, electrical plant, semiconductor plant ... etc. Taking the advantage of PUMP function, the BTC-2500 can be used for these applications to achieve an **economical** yet **versatile** solution. Here is an example:

PUMP: A Cost Effective yet Perfect Solution

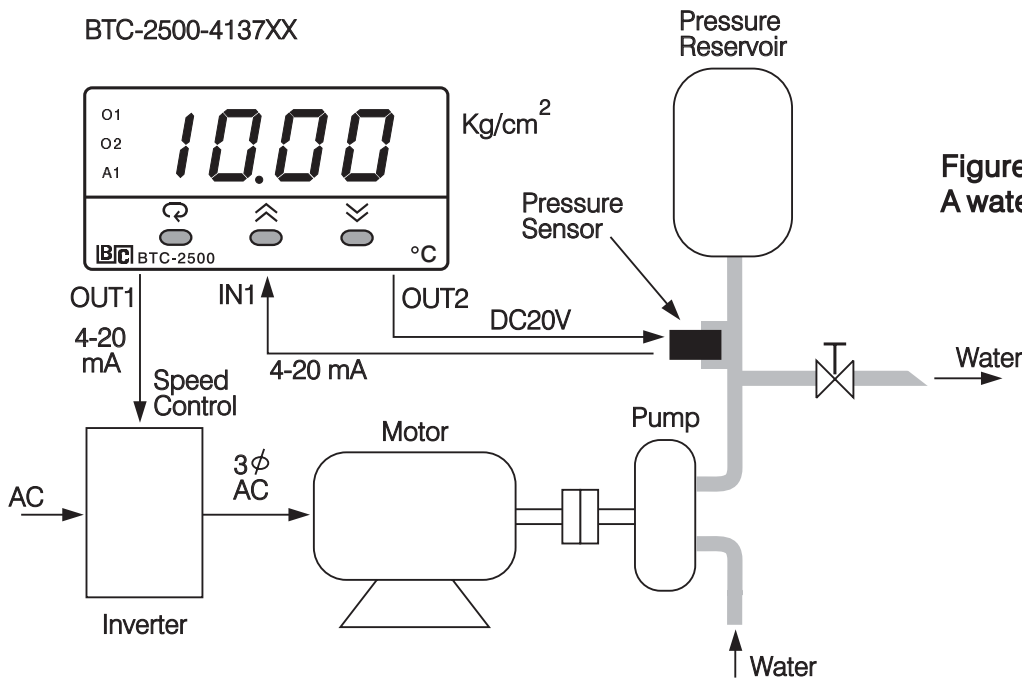

Figure 5.1
A water Supply System

The water pressure is required to be controlled at 10 Kg/cm^2 , to achieve this, the following devices are used for this example:

Inverter: To supply a variable frequency AC voltage to the motor.

Motor: A 3- ϕ induction motor.

Pump: An economical type

Pressure Sensor: A three-wire or two-wire type pressure transducer with 0-20 Kg/cm^2 range.

Pressure Reservoir: Providing a smoother pressure for the system.

BTC-2500-4137XX: Order a BTC-2500 with standard input, 4-20 mA output 1, 20V DC output 2 for sensor power.

Set the following parameters in the setup menu:

FUNC=FULL
COMM: optional
IN1=4-20
IN1U=PU
DP1=2-DP
IN1L=0
IN1H=20.00
IN2=NONE
OUT1=REVR
O1TY=4-20
O1FT=0
OUT2=DCPS
A1FN: optional
EIFN=NONE
PVMD=PV1
FILT=1
SELF=NONE
SLEP=NONE
SPMD=PUMP
SP1L=5.00
SP1H=15.00
SP2F=DEVI

Adjust the following parameters in the user menu:

A1SP: optional
REFC= 3
PB1=10.00
TI1=1
TD1=0.2
SP2= -0.50
PL1=100

Key menu:

SPMD
SP2F
REFC
SP2

Also refer to **Section 4-12** for more details.

5-2 Variable Period Full Wave SSR (VPFW SSR)

VPFW SSR is a variable period full wave solid-state relay. It can provide a zero cross output with superior controllability compared to a conventional SSR with a fixed time base. The block diagram of VPFW SSR is shown as follows:

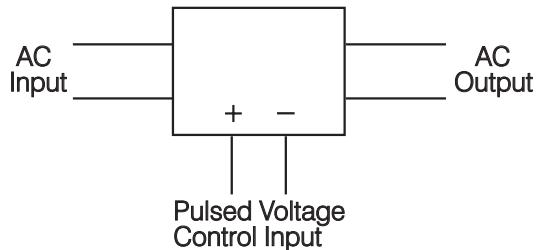

Figure 5.2
Block Diagram of VPFW SSR

Unlike a conventional SSR, the VPFW SSR always give the output an even number of half cycles (full wave) as shown in the following diagram.

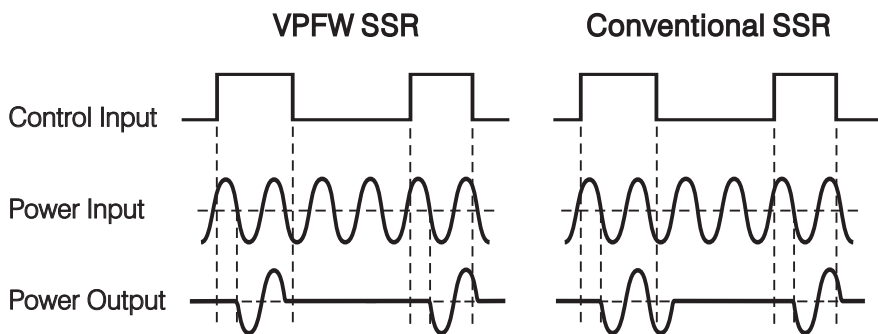

Figure 5.3 VPFW SSR
vs. Conventional SSR

The VPFW switches the load without DC current, hence minimize the harmonic current and stress on the load. The load life is prolonged.

As the duty cycle (ie. output power level) of the control input is small, the off period will be extended to keep the output resolution so that the conversion error is minimized. As low as 0.1% of timing error can be achieved. Hence, VPFW SSR is particularly suitable for a smoother control.

NOTES:

1. The VPFW SSR can be used to drive resistive load and some types of inductive load such as relay, contactor, magnetic switch, solenoid valve etc. However, it **can not drive Motor and Capacitance Load**.
2. Only **AC power** can supply VPFW SSR, otherwise, it will not operate properly.

The advantages of VPFW SSR over conventional SSR are summarized as following table:

Functions	VPFW SSR	Conventional SSR
Zero Cross Switching	Yes	Yes
Time Base	Variable	Fixed
Proportional Timing Error	±0.1%	±1% (for 1 sec. cycle time)
Control Achievement	Excellent	Good
Half on Cycles	Even	Even and Odd
DC Load Current	Zero	Nonzero
Harmonic Current	Low	Higher
Stress on the Load	Low	Higher
Load (Heater) Life	Longer	Shorter

Table 5.1
Function Comparison between
Conventional SSR and VPFW SSR

The output 1 and output 2 of BTC-2500 can be connected to VPFW SSR directly provided that a pulsed voltage drive output (BTC-2500-XX2XXX or BTC-2500-XXX2XX) is ordered.

Here is an example:

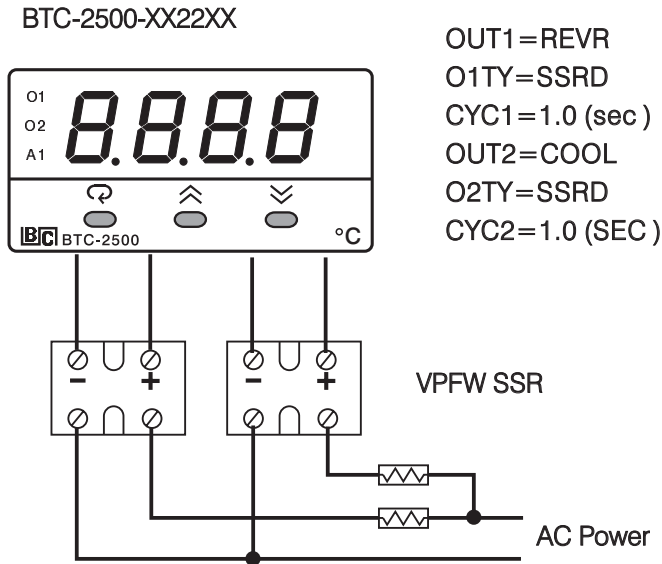
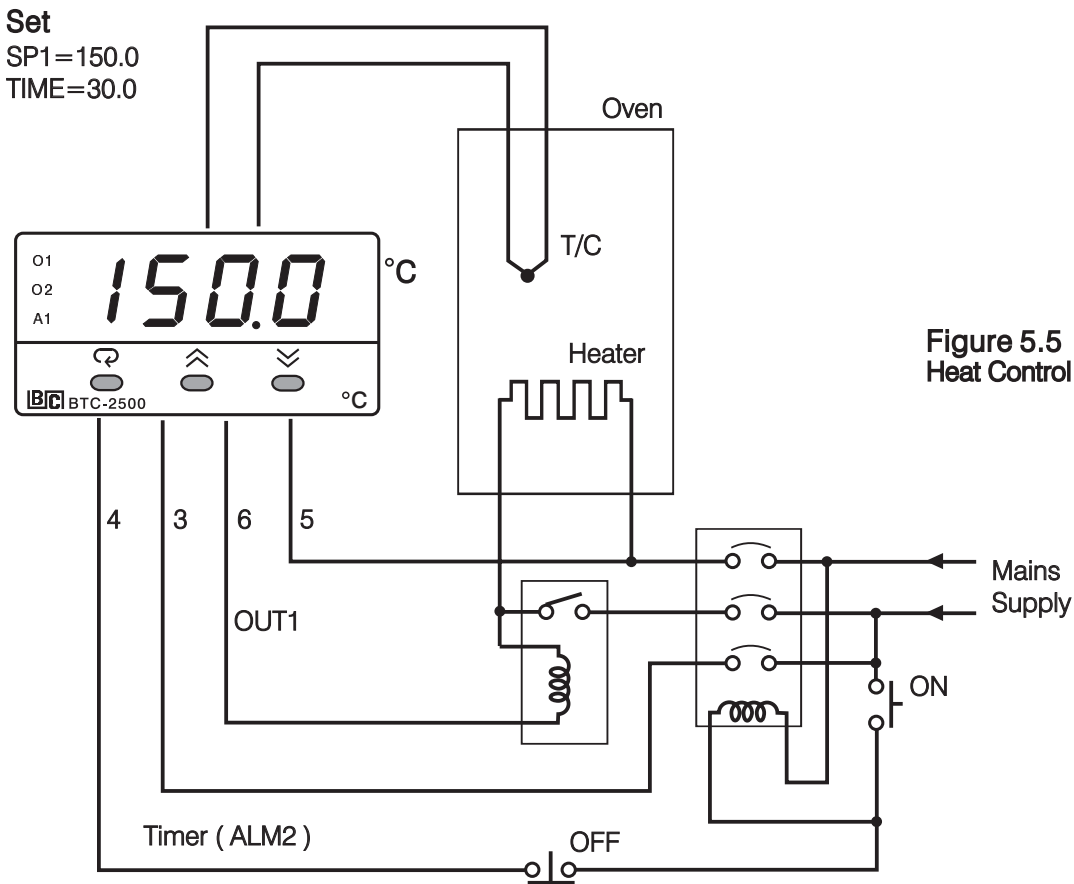

Figure 5.4
VPFW SSR Application Example

Three phase VPFW SSR's are also available upon request.

5-3 Heat Only Control

An oven is designed to dry the products at 150 °C for 30 minutes and then stay unpowered for another batch. A BTC-2500 equipped with **dwelt timer** is used for this purpose. The system diagram is shown as follows :



To achieve this function set the following parameters in the setup menu.

```

FUNC=BASC (Basic function )
IN1=K_TC
IN1U= °C
DP1=1_DP
OUT1=REVR
O1TY=RELY
CYC1=18.0
O1FT=BPLS
A2FN=TIMR
A2FT=ON
SELF=NONE
  
```

Auto-Tuning is performed at 150 °C for a new oven.

5-4 Cool Only Control

A BTC-2500 is used to control a refrigerator at temperature below 0 °C. To avoid the set point adjustment beyond the interesting range, SP1L is set at -10 °C and SP1H is set at 0 °C. The temperature is lower than the ambient, a cooling action is required. Hence select DIRT for OUT1. Since output 1 is used to drive a magnetic contactor, O1TY selects RELY. A small temperature oscillation is tolerable, hence use ON-OFF control to reduce the over-all cost. To achieve ON-OFF control, PB1 is set with zero and O1HY is set at 0.1 °C.

ON-OFF control
Direct Control Action

Setup Summary:

- FUNC=BASC
- IN1=PT.DN
- IN1U= °C
- DP1=1-DP
- OUT1=DIRT
- O1TY=RELY
- SP1L=-10 °C
- SP1H= 0 °C

User Menu:

- PB1=0 (°C)
- O1HY=0.1 (°C)

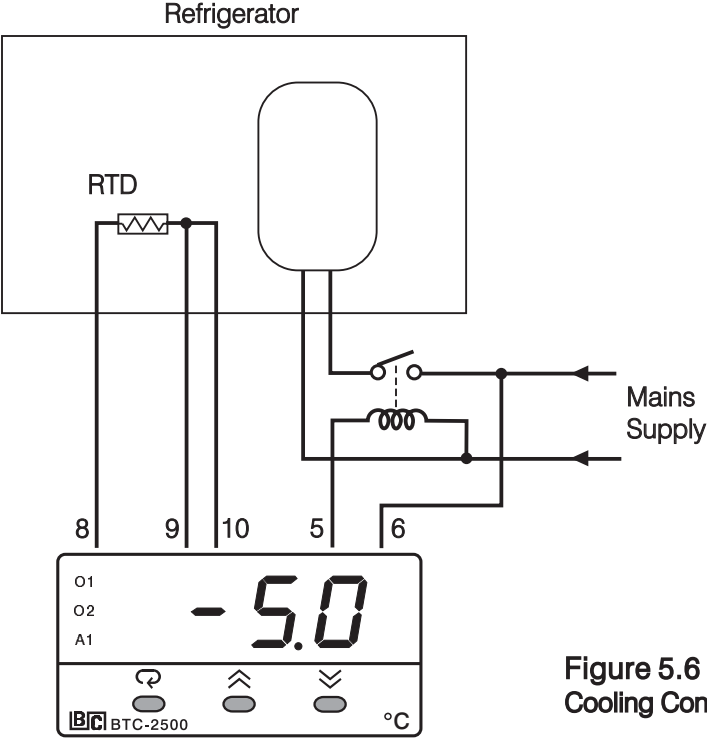

Figure 5.6
Cooling Control Example

5-5 Heat-Cool Control

An injection mold required to be controlled at 120 °C to ensure a consistent quality for the parts. An oil pipe is buried in the mold. Since plastics is injected at higher temperature (e.g. 250 °C), the circulation oil needs to be cooled as its temperature rises. Here is an example:

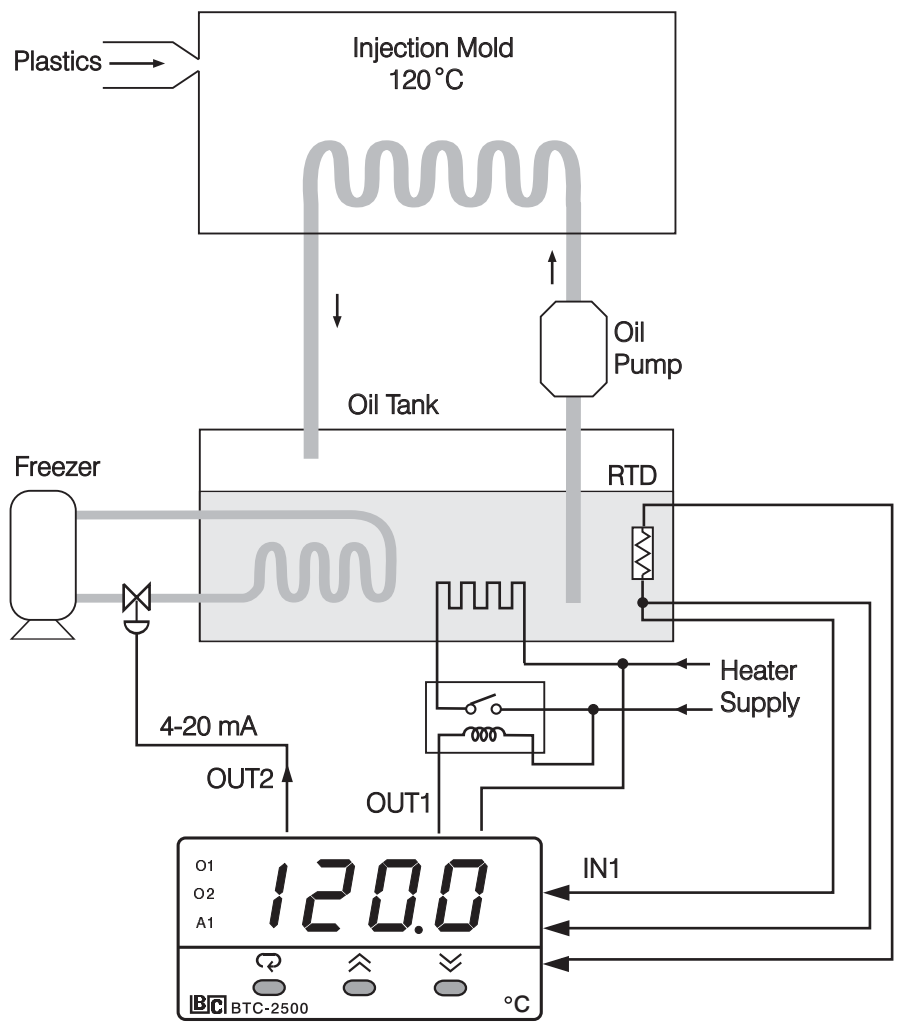

Figure 5.7
Heat-Cool Control Example

The PID Heat-Cool is used for the above example.

To achieve this set the following parameters in the Setup Menu:

FUNC=BASC
IN1=PT.DN
IN1U= °C
DP1=1-DP
OUT1=REVR
O1TY=RELY
CYC1=18.0 (sec)
O1FT=BPLS
OUT2=COOL
O2TY=4-20
O2FT=BPLS
SELF=STAR

Adjust SP1 at 120.0°C , CPB at 125 (%) and DB at -4.0 (%).

Apply **Auto-tuning** at 120°C for a new system to get an optimal PID values.
See **Section 3-20**.

Adjustment of CPB is related to the cooling media used. If water is used as cooling media instead of oil, the CPB is set at 250 (%). If air is used as cooling media instead of oil, the CPB is set at 100 (%).

Adjustment of DB is dependent on the system requirements. More positive value of DB will prevent unwanted cooling action, but will increase the temperature overshoot. while more negative value of DB will achieve less temperature overshoot, but will increase unwanted cooling action.

Key Menu

FUNC
IN1
IN1U
DP1
OUT1
O1TY
CYC1
O1FT
OUT2
O2TY
O2FT
SELF
SP1
CPB
DB

5-6 Ramp & Dwell

Example 1: Temperature cycling Chamber

A chamber is used to test the temperature cycling effect on the personal computers. An external cycle timer is used to control the event input for switching the set point. The products under test are required to stay at 60 °C for 1 hour and -10 °C for 30 minutes. The transition interval between high-low temperature is required to be 5 minutes. Make the following setup:

- EIFN=SPP2
- A1FN=TIMR
- OUT1=REVR, Relay Output
- OUT2=COOL, 4-20mA Output
- SPMD=MINR
- IN1U=°C
- DP1=1-DP

The circuit diagram and its temperature profile are shown below:

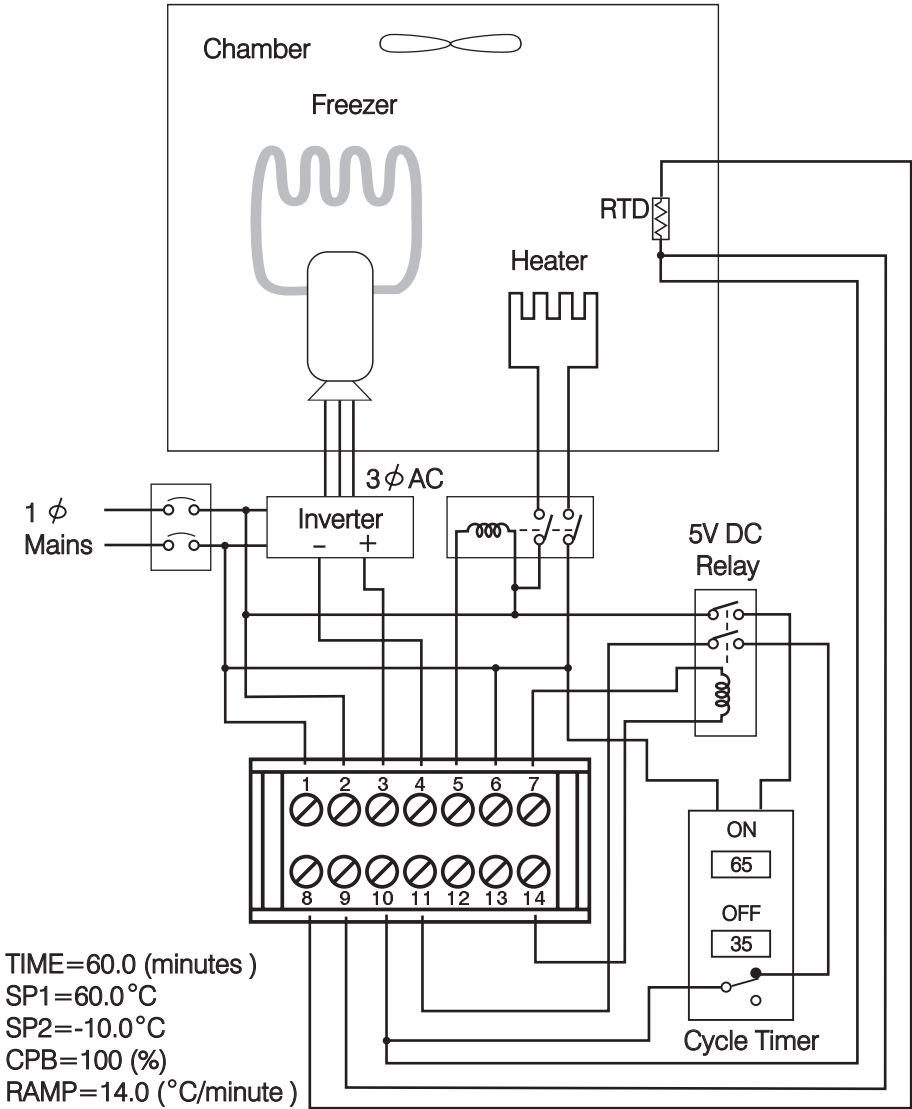

Figure 5.8
A Temperature Cycling Chamber

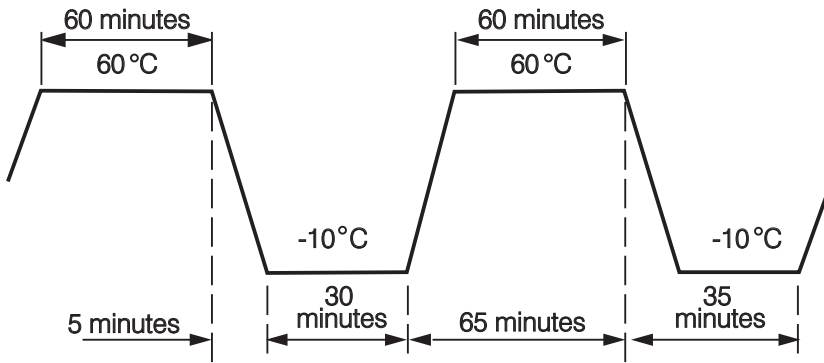

Figure 5.9
Temperature Profile of Chamber

BTC-2500 provides 4-20 mA signal to control the speed of the Inverter. SPP2 being chosen for EIFN is for the purpose of accomplishing a dual PID control. You can perform auto-tuning twice at SP1 and SP2 for initial setup to the dual PID values. Refer sections 3-20 and 4-3.

Example 2: Programmable Bread Baking Oven

Bread is baked in batches. A ramp is incorporated to control the thermal gradient to suit for making the bread. A dwell timer is used to shut off the oven power and announce the baker. The system is configured as shown in the following diagram.

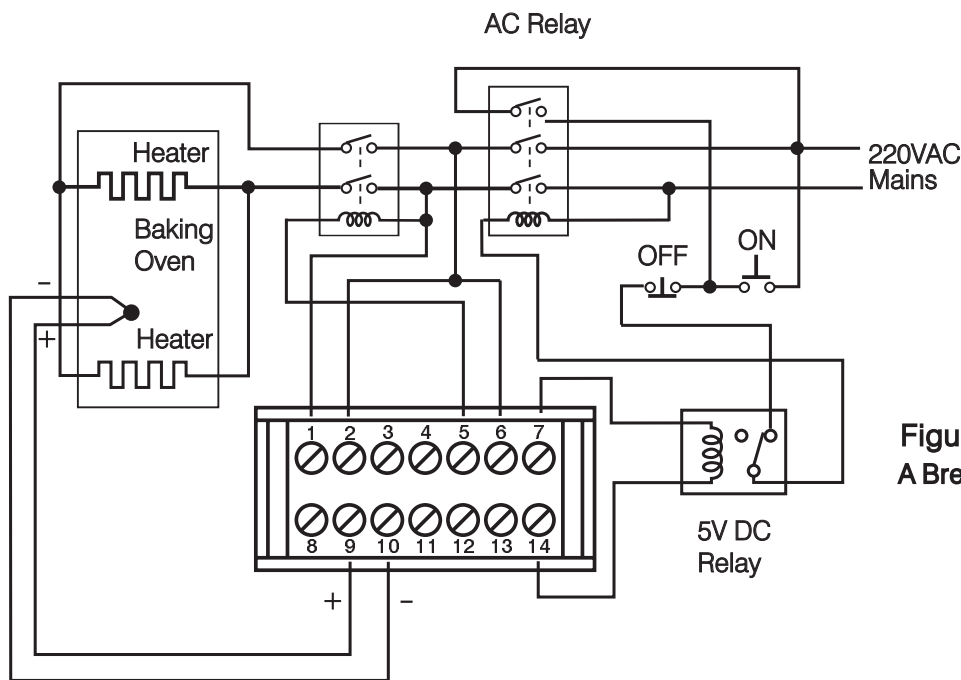

Figure 5.10
A Bread Baking Oven

Push ON switch to start a batch. The temperature will rise with a ramp rate determined by RAMP value. Bread is baked with the set point temperature for a definite time which is programmed by TIME value, and then the power is shut off. The temperature profile is shown in the following Figure.

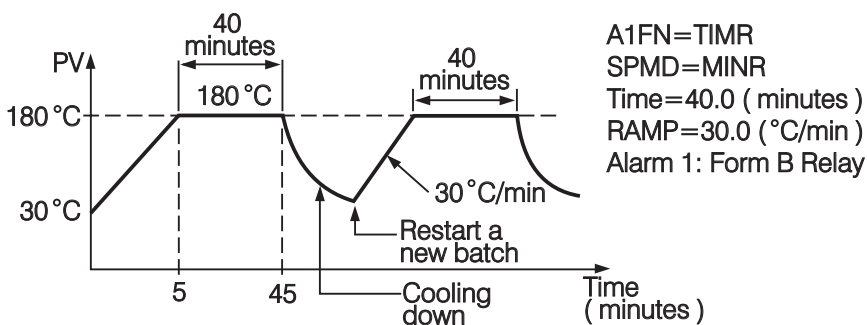

Figure 5.11
Temperature Profile of Baking Oven

5-7 Remote Set Point

An on-line multiple zone oven is used to dry paint. Since heat demand is various at different position in the production line, multiple zones with individual controls should be used to ensure a consistent temperature profile. If you order a BTC-2500 with a retransmission unit for the master controller, and retransmit its set point to the input 2 of the rest of slave controllers, each zone will be synchronized with the same temperature. Here is an example:

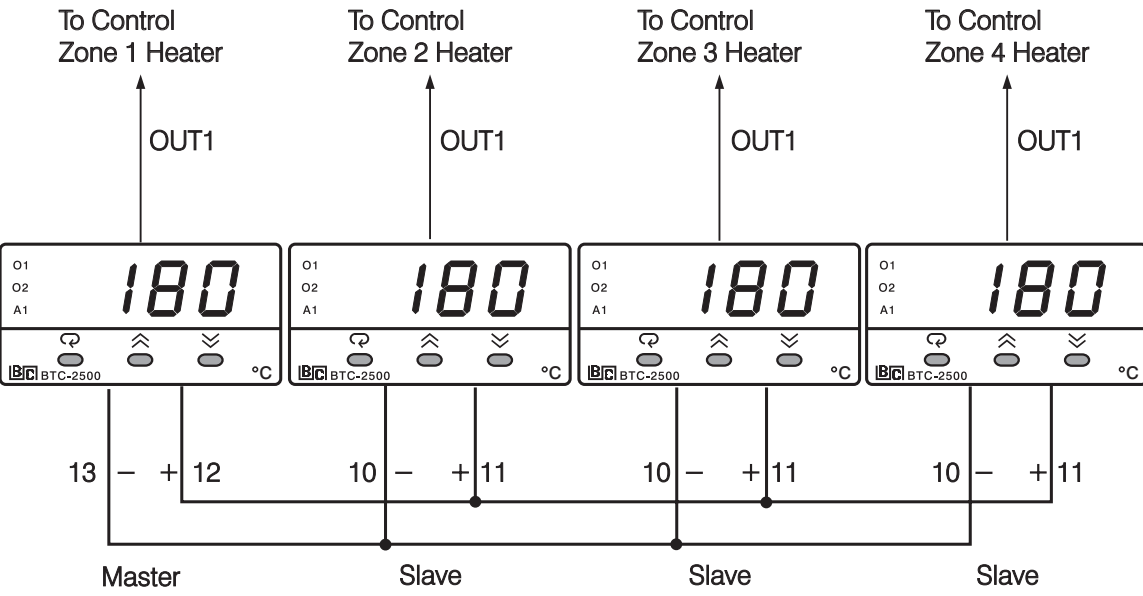

Figure 5.12
Remote Set Point Application

Set the following parameters in the setup menu:

- | | |
|------------------------|------------------------|
| For master unit | For slave units |
| FUNC= FULL | FUNC= FULL |
| COMM= 1-5 V | IN2= 1-5 V |
| AOLO= 0 °C | IN2L= 0 °C |
| AOHI = 300 °C | IN2H= 300°C |
| PVMD= PV1 | PVMD= PV1 |
| SPMD= SP1.2 | SPMD= PV2 |

Note: AOHI and IN2H should be set with values higher than the set point range used.

5-8 Differential Control

In certain applications it is desirable to control a second process such that its process value always deviates from the first process with a constant value. Water tank 1 is 5.12 meters height and water tank 2 level is desirable to be maintained at 1 meter lower than tank 1 level.

Set the following parameters in the setup menu:

FUNC= FULL

IN1, IN1L, IN1H : According to Sensor 1 signal

IN1U= PU

DP1= 2-DP

IN2, IN2L, IN2H : According to Sensor 2 signal(Current signal has to be converted to a voltage signal through a shunt resistor before sending to the controller input)

IN2U= PU

DP2= 2-DP

OUT1= REVR

O1TY= 4 20

PVMD= P1-2

SPMD=SP1.2

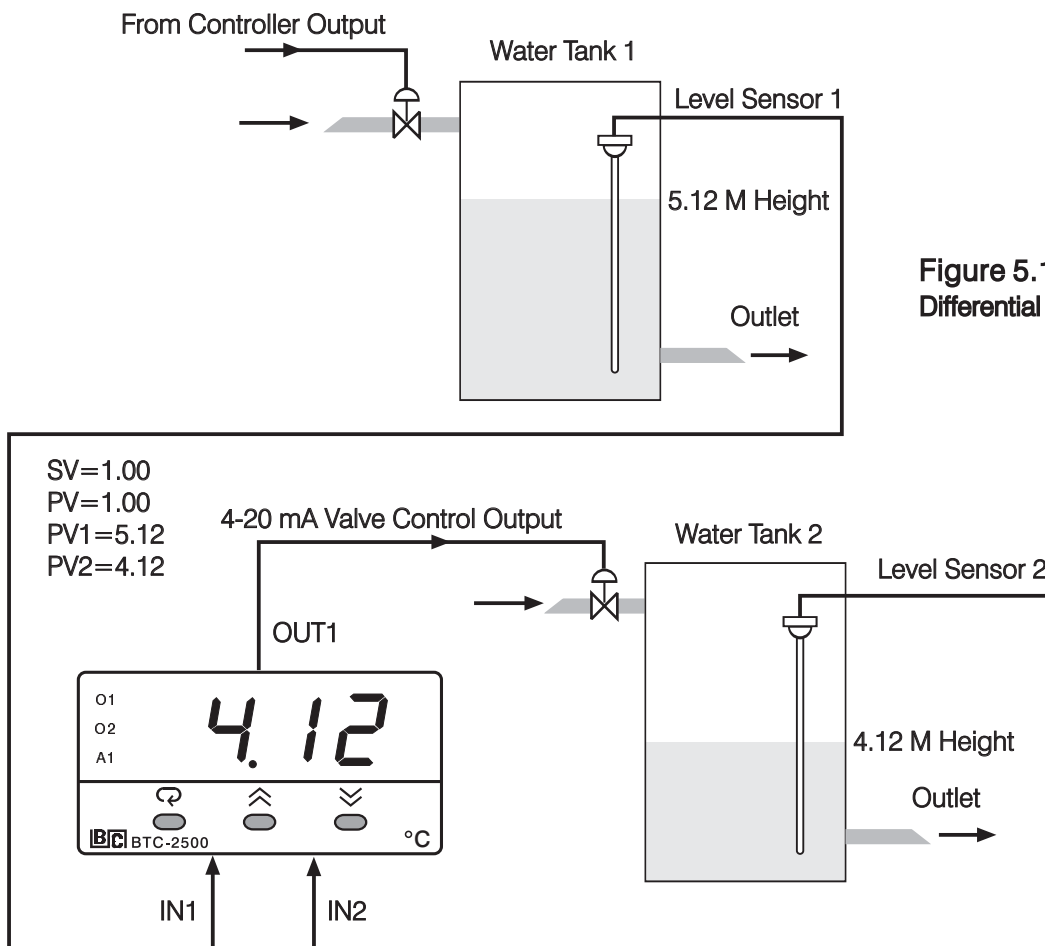

Figure 5.13
Differential Control Example

Adjust SP1(here is 1.00) to control the difference between PV1 and PV2. Choosing P1-2 for PVMD, the PV display will show the difference value (PV1- PV2) between PV1 and PV2, and this value will be stabilized to the set point (here is 1.00).

If you need PV1 or PV2 instead of PV, you can use the Display Mode to select PV1 or PV2 to be displayed. See Section 3-24. The above diagram indicates PV2 instead of PV.

5-9 Dual Set Point / PID

The BTC-2500 will switch between the two PID sets based on the process value, the set point or either of the event input. As the control ramps up to the higher process value, the process characteristics changes. As this happens, the original PID values are no longer valid. To achieve optimal control over the entire range, a second PID set is used.

Example 1: Single Set Point / Dual PID

A heat treating furnace is used over the range of 400 °C to 1200 °C.

(1) Set the following parameters in the Setup menu:

FUNC= FULL
 A1FN= PV1H
 A1MD= NORM
 EIFN= PID2
 PVMD= PV1
 SPMD= MINR

(2) Adjust the following parameters in the User menu:

A1SP= 800 °C
 A1HY= 1.0 °C
 PL1= 100 (%)
 RAMP: According to the process requirement
 SP1: According to the process requirement

(3) Tune first PID set at SP1= 500 °C and tune second PID set at SP1=1100 °C, or set the proper values for PB1, TI1, TD1, PB2, TI2 and TD2 directly according to the previous records to eliminate auto-tuning sequence.

The circuit diagram and its temperature profile are shown as follows :

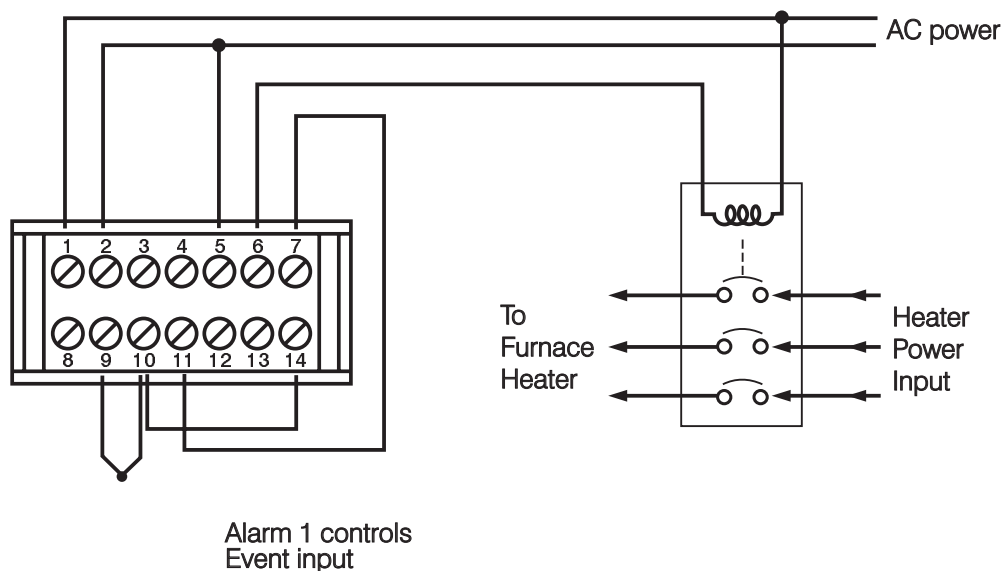

Figure 5.14
Dual PID Furnace

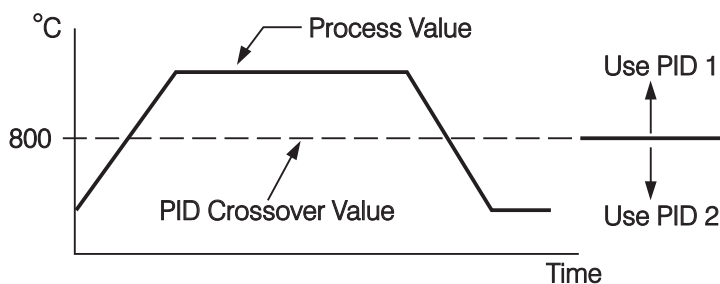

Figure 5.15
Dual PID Crossover

Example 2: Dual Set Point / PID

A heat treating furnace is required to harden the mold at a high temperature (1000°C) for 30 minutes, then the mold is cooled down with a programmable ramp (20°C / minute) toward a lower set point (200°C). Use the dual set point / PID and ramp / dwell functions for this application.

(1) Set the following parameters in the Setup menu:

FUNC= FULL
A1FN= TIMR
EIFN= SPP2
PVMD= PV1
SPMD= MINR

(2) Adjust the following parameters in the User menu:

TIME= 30.0 (Minutes)
RAMP= 20.0 (°C/Minute)
SP1= 1000°C
SP2= 200°C
PL1= 100 (%)

(3) Set the proper values for PB1, TI1, TD1, PB2, TI2 and TD2 directly according to the previous records. For a new system tune first PID set at SP1=800 °C and tune second PID set at SP2=400 °C.

The circuit diagram is same as shown in Figure 5.14. The temperature profile is shown as below:

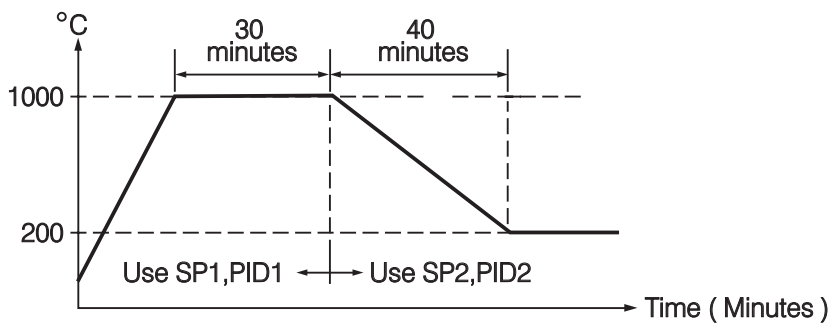

Figure 5.16
Dual Set Point /PID Profile

5-10 RS-485

A tile making plant has 5 production lines. Each production line is equipped with 16 units of BTC-2500 to control the temperature for the kiln. They are desirable to program the controllers and monitor the process in the control room for the purpose of improving the quality and productivity. A cost effective solution for the above application is to use 80 units of BTC-2500-XXXXX1 plus a SNA10B Smart Network Adaptor and BC-Net PC based software for this purpose.

The system is installed as shown in the following diagram.

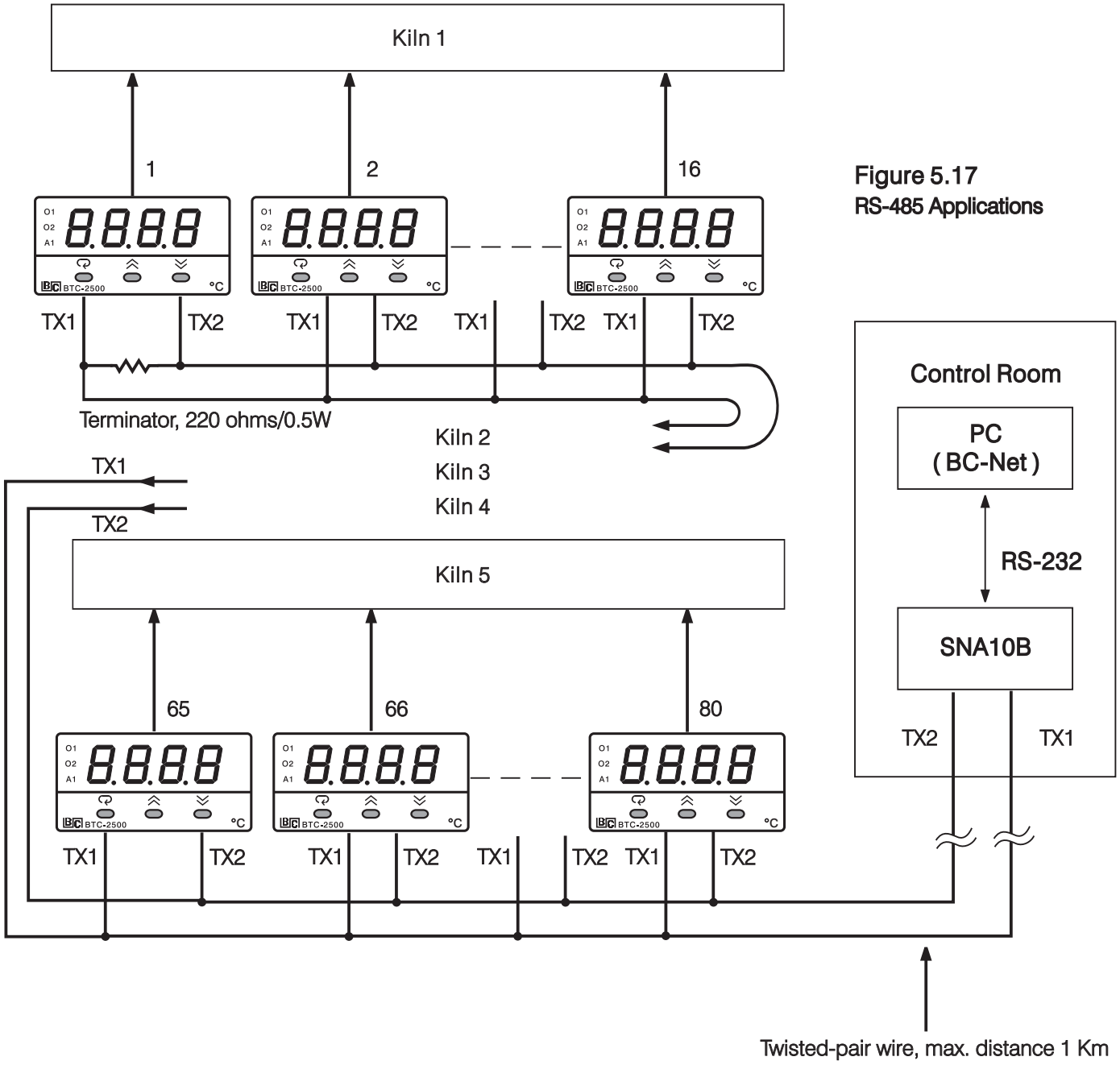

Figure 5.17
RS-485 Applications

Setup

Enters the setup mode to configure each BTC-2500. Choose FULL for FUNC, 485 for COMM, RTU for PROT and select an unequal address (ADDR) for each unit. Use the same values of BAUD, DATA, PARI and STOP for BTC-2500's, SNA10B and BC-Net. Also refer to **Section 2-15** and **Section 4-8**.

Taking the advantage of BC-Net software, the operator can monitor the process on the PC screen, program the set point as well as other control parameters such as PID values, down load the ramp and soak profile to the controllers, execute the manual control or trigger an auto-tuning.....etc. , and print out a report as required. The historical data can be saved in the floppy disc, hard disc or a CD for permanent storage purpose.

Setup Menu

FUNC
COMM
PROT
ADDR
BAUD
DATA
PARI
STOP

5-11 RS-232

Suppose a chemical experiment is performed in a laboratory. And an engineer desires to find out the relation between the chemical reaction and temperature. He uses a BTC-2500 to control the temperature of the solution under test. A testing report containing the relation between the concentration and temperature is particularly interested.

For a single unit application it is adequate to order a **BTC-2500-xxxxx2** with RS-232 communication and a **BC-Net** software. By using the BC-Net software the temperature data can be viewed and stored in a file. The user can program the temperature as well as other control parameters such as PID values. He can setup the controller, down load a ramp and soak profile, also execute the manual control or auto-tuning procedure etc. The results can be printed out or stored in a file for the future reference.

Refer to **Section 2-16** for installation and **Section 4-8** for setup procedure.

Setup Menu

FUNC
COMM
PROT
ADDR
BAUD
DATA
PARI
STOP

5-12 Retransmit

An air-conditioned room uses two units of BTC-2500 to control its temperature and humidity. The temperature and humidity are required to be recorded on a chart recorder. The interesting ranges for these two quantity are: 20°C to 30°C and 40% RH to 60% RH. The recorder inputs accept 0 - 5 V signal.

To achieve this, set the following parameters in the Setup menu.

UNIT 1:	UNIT 2:
FUNC= FULL	FUNC= FULL
COMM= 0 - 5V	COMM= 0 - 5V
AOFN=PV1	AOFN=PV1
AOLO=20.0 (°C)	AOLO=40.0 (%)
AOHI= 30.0 (°C)	AOHI= 60.0 (%)
IN1= PTDN	IN1= 0 - 1 V (According to humidity sensor)
IN1U= °C	IN1U= PU
DP1= 1-DP	DP1= 1-DP

SP1= 25.0
 SP1L= 20.0
 SP1H= 30.0

SP1= 50.0
 SP1L= 40.0
 SP1H= 60.0

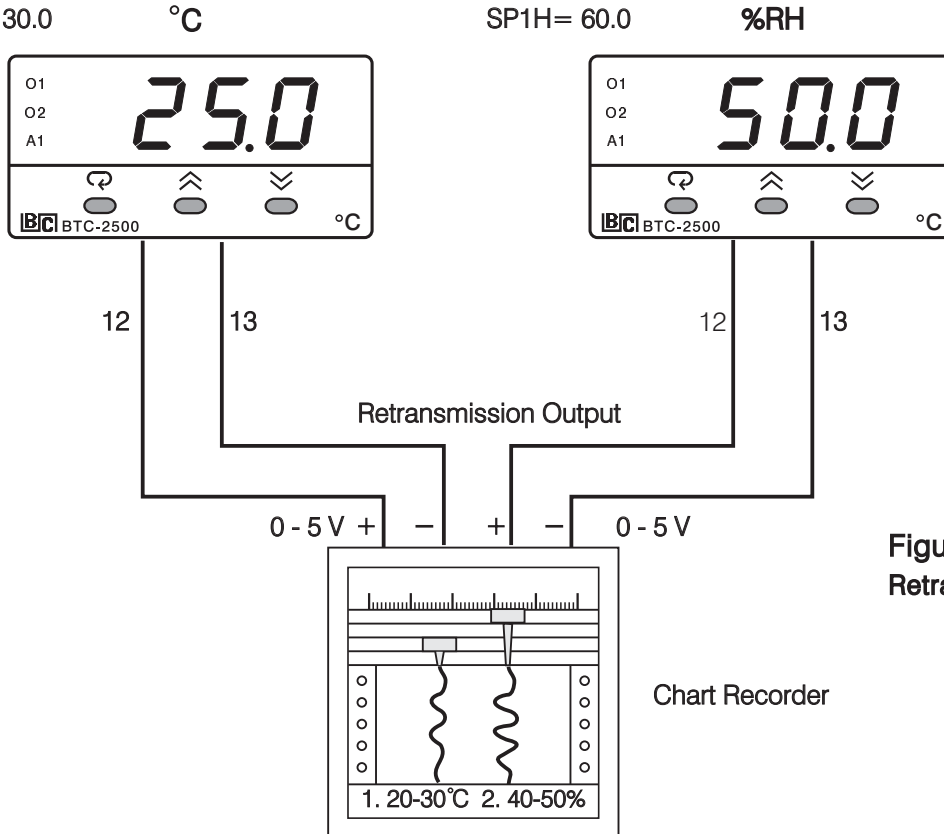

Figure 5.18
 Retransmission Application

SP1L and SP1H are used to limit the adjustment range of set point.

Chapter 6 Calibration



Do not proceed through this section unless there is a definite need to re-calibrate the controller. Otherwise, all previous calibration data will be lost. Do not attempt recalibration unless you have appropriate calibration equipment. If calibration data is lost, you will need to return the controller to your supplier who may charge you a service fee to re-calibrate the controller.



Entering calibration mode will break the control loop. Make sure that if the system is allowable to apply calibration mode.

Equipments needed before calibration:

- (1) A high accuracy calibrator (Fluke 5520A Calibrator recommended) with following functions:
 - 0 - 100 mV millivolt source with ± 0.005 % accuracy
 - 0 - 10 V voltage source with ± 0.005 % accuracy
 - 0 - 20 mA current source with ± 0.005 % accuracy
 - 0 - 300 ohm resistant source with ± 0.005 % accuracy
- (2) A test chamber providing 25 °C - 50 °C temperature range
- (3) A switching network (SW6400, optional for automatic calibration)
- (4) A calibration fixture equipped with programming units (optional for automatic calibration)
- (5) A PC installed with calibration software BC-Net and Smart Network Adaptor SNA10B (optional for automatic calibration)

The calibration procedures described in the following section are a step by step **manual procedures**.

Since it needs 30 minutes to warm up an unit before calibration, calibrating the unit one by one is quite inefficient. An **automatic calibration system** for small quantity as well as for unlimited quantity is available upon request.

Manual Calibration Procedures

* Perform step 1 to enter **calibration mode**.

Step 1. Set the lockout DIP switch to the unlocked condition (both switches 3 and 4 are off).

Press both scroll and down keys and release them quickly. The operation mode menu will appear on the display. Repeat the operation several times until **[CAL]** appear on the display.

Press scroll key for at least 3 seconds , the display will show **[ADU]** and the unit enters calibration mode . The output 1 and output 2 use their failure transfer values to control.

* Perform step 2 to calibrate **Zero** of A to D converter and step 3 to calibrate **gain** of A to D converter. The DIP switch is set for T/C input.

Step 2. Short terminals 9 and 10 , then press scroll key for at least 3 seconds. The display will blink a moment and a new value is obtained. Otherwise, if the display didn't blink or if the obtained value is equal to -360 or 360, then the calibration fails.

DIP Switch Position



T/C input

Step 3. Press scroll key until the display shows **[ADU]** . Send a 60mV signal to terminals 9 and 10 in correct polarity . Press scroll key for at least 3 seconds . The display will blink a moment and a new value is obtained . Otherwise , if the display didn't blink or if the obtained value is equal to -199.9 or 199.9, then the calibration fails.

* Perform step 4 to calibrate **voltage** function (if required) for input 1.

Step 4. Change the DIP switch for the Voltage input. Press scroll key until the display shows **[VU]** . Send a 10 V signal to terminals 9 and 10 in correct polarity. Press scroll key for at least 3 seconds . The display will blink a moment and a new value is obtained . Otherwise, if the display didn't blink or if the obtained value is equal to -199.9 or 199.9 , then the calibration fails.

DIP Switch Position



0–10V input

* Perform both steps 5 and 6 to calibrate **RTD** function (if required) for input 1.

Step 5. Change the DIP switch for the RTD input . Press scroll key until the display shows **[EEI]** . Send a 100 ohms signal to terminals 8, 9 and 10 according to the connection shown below:

DIP Switch Position



RTD input

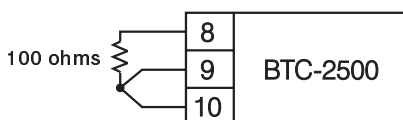

Press scroll key for at least 3 seconds . The display will blink a moment, otherwise the calibration fails.

Figure 6.1
RTD Calibration

Step 6. Press scroll key and the display will show $\boxed{5r.1}$. Change the ohm's value to 300 ohms .Press scroll key for at least 3 seconds. The display will blink a moment and two values are obtained for SR1 and REF1 (last step). Otherwise, if the display didn't blink or if any value obtained for SR1 and REF1 is equal to -199.9 or 199.9 , then the calibration fails.

* Perform step 7 to calibrate mA function (if required) for input 1.

Step 7. Change the DIP switch for mA input. Press scroll key until the display shows $\boxed{mA 1.0}$.Send a 20 mA signal to terminals 9 and 10 in correct polarity. Press scroll key for at least 3 seconds . The display will blink a moment and a new value is obtained . Otherwise , if the display didn't blink or if the obtained value is equal to -199.9 or 199.9, then the calibration fails.

DIP Switch Position



mA input

* Perform step 8 to calibrate voltage as well as CT function (if required) for input 2.

Step 8. Press scroll key until the display shows $\boxed{V 2.0}$. Send a 10 V signal to terminals 10 and 11 in correct polarity. Press scroll key for at least 3 seconds . The display will blink a moment and a new value is obtained . Otherwise , if the display didn't blink or if the obtained value is equal to -199.9 or 199.9 , then the calibration fails.

* Perform step 9 to calibrate offset of cold junction compensation, if required. The DIP switch is set for T/C input.

Step 9. Setup the equipments according to the following diagram for calibrating the cold junction compensation. Note that a K type thermocouple must be used.

DIP Switch Position



TC input

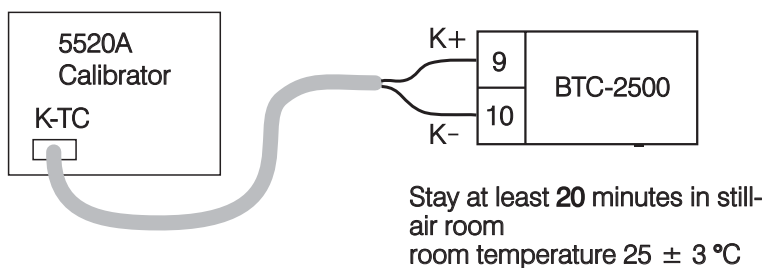

Figure 6.2
Cold Junction
Calibration Setup

The 5520A calibrator is configured as K type thermocouple output with internal compensation. Send a 0.00 °C signal to the unit under calibration.

The unit under calibration is powered in a still-air room with temperature $25 \pm 3^\circ\text{C}$. Stay at least 20 minutes for warming up. The DIP Switch is located at TC input .

Perform step 1 stated above, then press scroll key until the display shows $\boxed{\text{JEL}}$. Apply up/down key until value 0.00 is obtained . Press scroll key at least 3 seconds. The display will blink a moment and a new value is obtained . Otherwise , if the display didn't blink or if the obtained value is equal to -5.00 or 40.00, then the calibration fails.

- * Perform step 10 to calibrate **gain of cold junction** compensation if required, otherwise , perform step 10N to use a nominal value for the cold junction gain if a **test chamber** for calibration is **not available**.

Step 10. Setup the equipments same as step 9. The unit under calibration is powered in a still-air room with temperature $50 \pm 3^\circ\text{C}$. Stay at least 20 minutes for warming up . The calibrator source is set at 0.00°C with internal compensation mode.

Perform step 1 stated above , then press scroll key until the display shows $\boxed{\text{JG}}$. Apply up/down key until value 0.0 is obtained. Press scroll key for at least 3 seconds . The display will blink a moment and a new value is obtained. Otherwise , if the display didn't blink or if the obtained value is equal to -199.9 or 199.9, then the calibration fails.

This setup is performed in a **high temperature chamber**, hence it is recommended to use a computer to perform the procedures.

Step 10N. Perform step 1 stated above , then press scroll key until the display shows $\boxed{\text{JG}}$. Apply up/down key until value 0.1 is obtained. Press scroll key for at least 3 seconds. The display will blink a moment and the new value 0.0 is obtained. Otherwise , the calibration fails.

Caution: It is **not recommended** to use this step 10N, since the **cold junction gain is not able** to achieve rated accuracy by this step.

- * Final step

Step 11. Set the DIP switch to your desired position (refer to **section 1-3**).

Automatic Calibration Procedures

The programming port (See **Section 2-18**) of BTC-2500 can be used for automatic calibration.

The equipments required for automatic calibration are available upon request.

Chapter 7 Error Codes & Troubleshooting

 This procedure requires access to the circuitry of a live power unit. Dangerous accidental contact with line voltage is possible. Only qualified personnel are allowable to perform these procedures. Potentially lethal voltages are present.

Troubleshooting Procedures :

- (1) If an error message is displayed, refer to **Table 7.1** to see what cause it is and apply a corrective action to the failure unit.
- (2) Check each point listed below. Experience has proven that many control problems are caused by a defective instrument.
 - * Line wires are improperly connected
 - * No voltage between line terminals
 - * Incorrect voltage between line terminals
 - * Connections to terminals are open, missing or loose
 - * Thermocouple is open at tip
 - * Thermocouple lead is broken
 - * Shorted thermocouple leads
 - * Short across terminals
 - * Open or shorted heater circuit
 - * Open coil in external contactor
 - * Burned out line fuses
 - * Burned out relay inside control
 - * Defective solid-state relays
 - * Defective line switches
 - * Burned out contactor
 - * Defective circuit breakers
- (3) If the points listed on the above chart have been checked and the controller does not function properly, it is suggested that the instrument be returned to the factory for inspection.
Do not attempt to make repairs without qualified engineer and proper technical information . It may create costly damage. Also , it is advisable to use adequate packing materials to prevent damage in transportation.
- (4) Dismantle the controller according to **Figure 7.1** .
Refer to **Table 7.2** for some probable causes and actions.

- ① Press both sides of the latch located on rear terminal block. Hold tightly and remove the terminal block from the housing.
- ② Expand the rear edge of the housing by using a tool. Pull out the PCB from the housing.

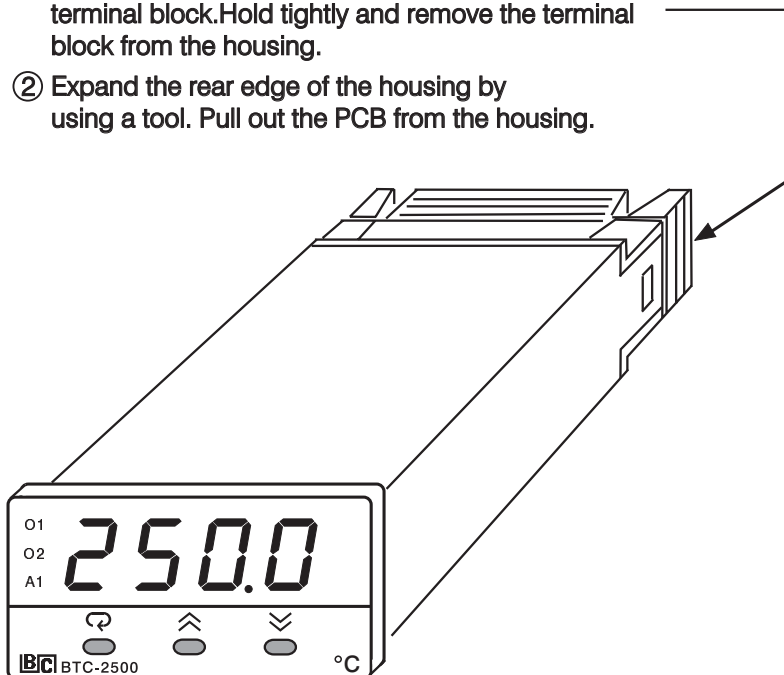

Figure 7.1
Dismantling the Controller

Table 7.1 Error Codes and Corrective Actions

Error Code	Display Symbol	Error Description	Corrective Action
1	<i>Er01</i>	Illegal setup values been used: PV1 is used for both PVMD and SPMD. It is meaningless for control.	Check and correct setup values of PVMD and SPMD. PV and SV can't use the same value for normal control
2	<i>Er02</i>	Illegal setup values been used: PV2 is used for both PVMD and SPMD. It is meaningless for control	Same as error code 1
3	<i>Er03</i>	Illegal setup values been used: P1-2 or P2-1 is used for PVMD while PV1 or PV2 is used for SPMD. Dependent values used for PV and SV will create incorrect result of control	Check and correct setup values of PVMD and SPMD. Difference of PV1 and PV2 can't be used for PV while PV1 or PV2 is used for SV
4	<i>Er04</i>	Illegal setup values been used: Before COOL is used for OUT2, DIRT (cooling action) has already been used for OUT1, or PID mode is not used for OUT1 (that is PB1 or PB2 = 0, and T11 or T12 = 0)	Check and correct setup values of OUT2, PB1, PB2, T11, T12 and OUT1. IF OUT2 is required for cooling control, the control should use PID mode (PB ≠ 0, T1 ≠ 0) and OUT1 should use reverse mode (heating action), otherwise, don't use OUT2 for cooling control
5	<i>Er05</i>	Illegal setup values been used: unequal IN1U and IN2U or unequal DP1 and DP2 while P1-2 or P2-1 is used for PVMD or, PV1 or PV2 is used for SPMD or, P1.2.H, P1.2.L, D1.2.H or D1.2.L are used for A1FN or A2FN.	Check and correct setup values of IN1U, IN2U, DP1, DP2, PVMD, SPMD, A1FN or A2FN. Same unit and decimal point should be used if both PV1 and PV2 are used for PV, SV, alarm 1 or alarm 2.
6	<i>Er06</i>	Illegal setup values been used: OUT2 select =AL2 but A2FN select NONE	Check and correct setup values of OUT2 and A2FN. OUT2 will not perform alarm function if A2FN select NONE.
7	<i>Er07</i>	Illegal setup values been used: Dwell timer (TIMR) is selected for both A1FN and A2FN.	Check and correct setup values of A1FN and A2FN. Dwell timer can only be properly used for single alarm output.
10	<i>Er10</i>	Communication error: bad function code	Correct the communication software to meet the protocol requirements.
11	<i>Er11</i>	Communication error: register address out of range	Don't issue an over-range register address to the slave.
12	<i>Er12</i>	Communication error: access a non-existent parameter	Don't issue a non-existent parameter to the slave.
14	<i>Er14</i>	Communication error: attempt to write a read-only data	Don't write a read-only data or a protected data to the slave.
15	<i>Er15</i>	Communication error: write a value which is out of range to a register	Don't write an over-range data to the slave register.
26	<i>AtEr</i>	Fail to perform auto-tuning function	<ol style="list-style-type: none"> 1. The PID values obtained after auto-tuning procedure are out of range. Retry auto-tuning. 2. Don't change set point value during auto-tuning procedure. 3. Don't change Event input state during auto-tuning procedure. 4. Use manual tuning instead of auto-tuning.
29	<i>EePe</i>	EEPROM can't be written correctly	Return to factory for repair.
38	<i>Sb2E</i>	Input 2 (IN2) sensor break, or input 2 current below 1 mA if 4-20 mA is selected, or input 2 voltage below 0.25V if 1 - 5V is selected	Replace input 2 sensor.
39	<i>Sb1E</i>	Input 1 (IN1) sensor break, or input 1 current below 1 mA if 4-20 mA is selected, or input 1 voltage below 0.25V if 1 - 5V is selected	Replace input 1 sensor.
40	<i>AdEr</i>	A to D converter or related component(s) malfunction	Return to factory for repair.

Table 7.2 Common Failure Causes and Corrective Actions

Symptom	Probable Causes	Corrective Actions
1) Keypad no function	-Bad connection between PCB & keypads	- Clean contact area on PCB - Replace keypads
2) LED's will not light	- No power to instrument - Power supply defective	- Check power line connections - Replace power supply board
3) Some segments of the display or LED lamps not lit or lit erroneously.	- LED display or LED lamp defective - Related LED driver defective	- Replace LED display or LED lamp - Replace the related transistor or IC chip
4) Display Unstable	- Analog portion or A-D converter defective - Thermocouple, RTD or sensor defective - Intermittent connection of sensor wiring	- Replace related components or board - Check thermocouple, RTD or sensor - Check sensor wiring connections
5) Considerable error in temperature indication	- Wrong sensor or thermocouple type, wrong input mode selected. - Analog portion of A-D converter defective	- Check sensor or thermocouple type and if proper input mode was selected - Replace related components or board
6) Display goes in reverse direction (counts down scale as process warms)	- Reversed input wiring of sensor	- Check and correct
7) No heat or output	- No heater power (output), incorrect output device used - Output device defective - Open fuse outside of the instrument	- Check output wiring and output device - Replace output device - Replace output fuse
8) Heat or output stays on but indicator reads normal	- Output device shorted, or power service shorted	- Check and replace
9) Control abnormal or operation incorrect	- CPU or EEPROM (non-volatile memory) defective. Key switch defective - Incorrect setup values	- Check and replace - Read the setup procedure carefully
10) Display blinks; entered values change by themselves	- Electromagnetic interference (EMI), or Radio Frequency interference (RFI) - EEPROM defective	- Suppress arcing contacts in system to eliminate high voltage spike sources. Separate sensor and controller wiring from " dirty " power lines, ground heaters - Replace EEPROM

Chapter 8 Specifications

Power

90–264 VAC, 47–63 Hz, 15VA, 7W maximum
 11–26 VAC / VDC, SELV, Limited Energy
 15VA, 7W maximum

Input 1

Resolution : 18 bits
 Sampling Rate : 5 times / second
 Maximum Rating : -2 VDC minimum, 12 VDC maximum
 (1 minute for mA input)
 Temperature Effect : $\pm 1.5 \mu\text{V}/^\circ\text{C}$ for all inputs except
 mA input
 $\pm 3.0 \mu\text{V}/^\circ\text{C}$ for mA input

Sensor Lead Resistance Effect :

T/C: 0.2uV/ohm
 3-wire RTD: 2.6 $^\circ\text{C}/\text{ohm}$ of resistance difference of two
 leads
 2-wire RTD: 2.6 $^\circ\text{C}/\text{ohm}$ of resistance sum of two leads

Burn-out Current : 200 nA

Common Mode Rejection Ratio (CMRR): 120dB

Normal Mode Rejection Ratio (NMRR): 55dB

Sensor Break Detection :

Sensor open for TC, RTD and mV inputs,
 below 1 mA for 4-20 mA input,
 below 0.25V for 1 - 5 V input,
 unavailable for other inputs.

Sensor Break Responding Time :

Within 4 seconds for TC, RTD and mV inputs,
 0.1 second for 4-20 mA and 1 - 5 V inputs.

Characteristics:

Type	Range	Accuracy @ 25 $^\circ\text{C}$	Input Impedance
J	-120 $^\circ\text{C}$ -1000 $^\circ\text{C}$ (-184 $^\circ\text{F}$ -1832 $^\circ\text{F}$)	$\pm 2^\circ\text{C}$	2.2 M Ω
K	-200 $^\circ\text{C}$ -1370 $^\circ\text{C}$ (-328 $^\circ\text{F}$ -2498 $^\circ\text{F}$)	$\pm 2^\circ\text{C}$	2.2 M Ω
T	-250 $^\circ\text{C}$ -400 $^\circ\text{C}$ (-418 $^\circ\text{F}$ -752 $^\circ\text{F}$)	$\pm 2^\circ\text{C}$	2.2 M Ω
E	-100 $^\circ\text{C}$ -900 $^\circ\text{C}$ (-148 $^\circ\text{F}$ -1652 $^\circ\text{F}$)	$\pm 2^\circ\text{C}$	2.2 M Ω
B	0 $^\circ\text{C}$ -1820 $^\circ\text{C}$ (-32 $^\circ\text{F}$ -3308 $^\circ\text{F}$)	$\pm 2^\circ\text{C}$ (200 $^\circ\text{C}$ -1820 $^\circ\text{C}$)	2.2 M Ω
R	0 $^\circ\text{C}$ -1767.8 $^\circ\text{C}$ (-32 $^\circ\text{F}$ -3214 $^\circ\text{F}$)	$\pm 2^\circ\text{C}$	2.2 M Ω
S	0 $^\circ\text{C}$ -1767.8 $^\circ\text{C}$ (-32 $^\circ\text{F}$ -3214 $^\circ\text{F}$)	$\pm 2^\circ\text{C}$	2.2 M Ω
N	-250 $^\circ\text{C}$ -1300 $^\circ\text{C}$ (-418 $^\circ\text{F}$ -2372 $^\circ\text{F}$)	$\pm 2^\circ\text{C}$	2.2 M Ω
L	-200 $^\circ\text{C}$ -900 $^\circ\text{C}$ (-328 $^\circ\text{F}$ -1652 $^\circ\text{F}$)	$\pm 2^\circ\text{C}$	2.2 M Ω
PT100 (DIN)	-210 $^\circ\text{C}$ -700 $^\circ\text{C}$ (-346 $^\circ\text{F}$ -1292 $^\circ\text{F}$)	$\pm 0.4^\circ\text{C}$	1.3 K Ω
PT100 (JIS)	-200 $^\circ\text{C}$ -600 $^\circ\text{C}$ (-328 $^\circ\text{F}$ -1112 $^\circ\text{F}$)	$\pm 0.4^\circ\text{C}$	1.3 K Ω
mV	-8mV - 70mV	$\pm 0.05\%$	2.2 M Ω
mA	-3mA - 27mA	$\pm 0.05\%$	70.5 Ω
V	-1.3V - 11.5V	$\pm 0.05\%$	302 K Ω

Input 2

Resolution : 18 bits
 Sampling Rate : 1.66 times / second
 Maximum Rating : -2 VDC minimum, 12 VDC maximum
 Temperature Effect : $\pm 1.5 \mu\text{V}/^\circ\text{C}$
 Common Mode Rejection Ratio (CMRR): 120dB
 Normal Mode Rejection Ratio (NMRR): 55dB

Sensor Break Detection :

below 0.25V for 1 - 5V input,
 unavailable for other inputs.

Sensor Break Responding Time : 0.5 second

Characteristics:

Type	Range	Accuracy @ 25 $^\circ\text{C}$	Input Impedance
CT94-1	0–50.0 A	$\pm 2\%$ of Reading $\pm 0.2 \text{ A}$	265 K Ω
V	-1.3V–11.5V	$\pm 0.05\%$	265 K Ω

Input 3 (Event Input)

Logic Low : -10V minimum, 0.28V maximum.
 Logic High : Open or 0.32V minimum, 10V maximum
 External pull-down Resistance : 200 K Ω maximum
 External pull-up Resistance : not necessary
 Functions : Select second set point and/or PID,
 reset alarm 1 and/or alarm 2,
 disable output 1 and/or output 2,
 remote lockout.

Output 1 / Output 2

Relay Rating : 2A/240 VAC, life cycles 200,000 for
 resistive load
 Pulsed Voltage : Source Voltage 5V,
 current limiting resistance 66 Ω .

Linear Output Characteristics

Type	Zero Tolerance	Span Tolerance	Load Capacity
4-20 mA	3.8-4 mA	20-21 mA	500 Ω max.
0-20 mA	0 mA	20-21 mA	500 Ω max.
0–5 V	0 V	5 – 5.25 V	10 K Ω min.
1–5 V	0.95–1 V	5 – 5.25 V	10 K Ω min.
0–10 V	0 V	10 –10.5 V	10 K Ω min.

Linear Output

Resolution : 15 bits
 Output Regulation : 0.01 % for full load change
 Output Settling Time : 0.1 sec. (stable to 99.9 %)
 Isolation Breakdown Voltage : 1000 VAC
 Temperature Effect : ± 0.0025 % of SPAN / °C

Triac (SSR) Output

Rating : 1A / 240 VAC
 Inrush Current : 20A for 1 cycle
 Min. Load Current : 50 mA rms
 Max. Off-state Leakage : 3 mA rms
 Max. On-state Voltage : 1.5 V rms
 Insulation Resistance : 1000 Mohms min. at 500 VDC
 Dielectric Strength : 2500 VAC for 1 minute

DC Voltage Supply Characteristics (Installed at Output 2)

Type	Tolerance	Max. Output Current	Ripple Voltage	Isolation Barrier
20 V	± 0.5 V	25 mA	0.2 Vp-p	500 VAC
12 V	± 0.3 V	40 mA	0.1 Vp-p	500 VAC
5 V	± 0.15 V	80 mA	0.05 Vp-p	500 VAC

Alarm 1/ Alarm 2

Alarm 1 : 5V DC logic output, max. source current 100mA, short circuit unprotected.
 Alarm 2 Relay : Form A, Max. rating 2A/240VAC, life cycles 200,000 for resistive load.
 Alarm Functions : Dwell timer,
 Deviation High / Low Alarm,
 Deviation Band High / Low Alarm,
 PV1 High / Low Alarm,
 PV2 High / Low Alarm,
 PV1 or PV2 High / Low Alarm,
 PV1-PV2 High / Low Alarm,
 Loop Break Alarm,
 Sensor Break Alarm.
 Alarm Mode : Normal, Latching, Hold, Latching / Hold.
 Dwell Timer : 0 - 6553.5 minutes

Data Communication

Interface : RS-232 (1 unit), RS-485 (up to 247 units)
 Protocol : Modbus Protocol RTU mode
 Address : 1 - 247
 Baud Rate : 0.3 ~ 38.4 Kbits/sec
 Data Bits : 7 or 8 bits
 Parity Bit : None, Even or Odd
 Stop Bit : 1 or 2 bits
 Communication Buffer : 50 bytes

Analog Retransmission

Functions : PV1, PV2, PV1-PV2, PV2-PV1, Set Point, MV1, MV2, PV-SV deviation value
 Output Signal : 4-20 mA, 0-20 mA, 0 - 1V, 0 - 5V, 1 - 5V, 0 - 10V

Resolution : 15 bits
 Accuracy : ± 0.05 % of span ± 0.0025 % / °C
 Load Resistance :
 0 - 500 ohms (for current output)
 10 K ohms minimum (for voltage output)
 Output Regulation : 0.01 % for full load change
 Output Settling Time : 0.1 sec. (stable to 99.9 %)
 Isolation Breakdown Voltage : 1000 VAC min.
 Integral Linearity Error : ± 0.005 % of span
 Temperature Effect : ± 0.0025 % of span / °C
 Saturation Low : 0 mA (or 0V)
 Saturation High : 22.2 mA (or 5.55V, 11.1V min.)
 Linear Output Range : 0-22.2mA(0-20mA or 4-20mA)
 0-5.55V (0 - 5V, 1 - 5V)
 0 - 11.1 V (0 - 10V)

User Interface

Dual 4-digit LED Displays : Upper 0.4" (10 mm),
 Lower 0.3" (8 mm)
 Keypad : 3 keys
 Programming Port : For automatic setup, calibration and testing
 Communication Port : Connection to PC for supervisory control

Control Mode

Output 1 : Reverse (heating) or direct (cooling) action
 Output 2 : PID cooling control, cooling P band 1~255% of PB
 ON-OFF : 0.1 - 100.0 (°F) hysteresis control (P band = 0)
 P or PD : 0 - 100.0 % offset adjustment
 PID : Fuzzy logic modified
 Proportional band 0.1 ~ 900.0 °F.
 Integral time 0 - 1000 seconds
 Derivative time 0 - 360.0 seconds
 Cycle Time : 0.1 - 100.0 seconds
 Manual Control : Heat (MV1) and Cool (MV2)
 Auto-tuning : Cold start and warm start
 Self-tuning : Select None and YES
 Failure Mode : Auto-transfer to manual mode while sensor break or A-D converter damage
 Sleep Mode : Enable or Disable
 Ramping Control : 0 - 900.0 °F/minute or 0 - 900.0 °F/hour ramp rate
 Power Limit : 0 - 100 % output 1 and output 2
 Pump / Pressure Control : Sophisticated functions provided
 Remote Set Point : Programmable range for voltage or current input
 Differential Control : Control PV1-PV2 at set point

Digital Filter

Function : First order
 Time Constant : 0, 0.2, 0.5, 1, 2, 5, 10, 20, 30, 60 seconds programmable

Environmental & Physical

Operating Temperature : -10 °C to 50 °C
Storage Temperature : -40 °C to 60 °C
Humidity : 0 to 90 % RH (non-condensing)
Insulation Resistance : 20 Mohms min. (at 500 VDC)
Dielectric Strength : 2000 VAC, 50/60 Hz for 1 minute
Vibration Resistance : 10 - 55 Hz, 10 m/s² for 2 hours
Shock Resistance : 200 m/s² (20 g)
Moldings : Flame retardant polycarbonate
Dimensions : 50mm(W) X 26.5mm(H) X 110.5mm(D),
98.0 mm depth behind panel
Weight : 120 grams

Approval Standards

Safety : UL873 (11th edition, 1994)
CSA C22.2 No. 24-93
EN61010-1 (IEC1010-1)
Protective Class :
NEMA 4X (IP65) front panel, indoor use,
IP 20 housing and terminals
EMC: EN61326

Chapter 9 Modbus Communications

This chapter specifies the Modbus Communications protocol as RS-232 or RS-485 interface module is installed. Only RTU mode is supported. Data is transmitted as eight-bit binary bytes with 1 start bit, 1 stop bit and optional parity checking (None, Even or Odd). Baud rate may be set to 300, 600, 1200, 2400, 4800, 9600, 14400, 19200, 28800 and 38400.

9-1 Functions Supported

Only function 03, 06 and 16 are available for this series of controllers. The message formats for each function are described as follows:

Function 03: Read Holding Registers

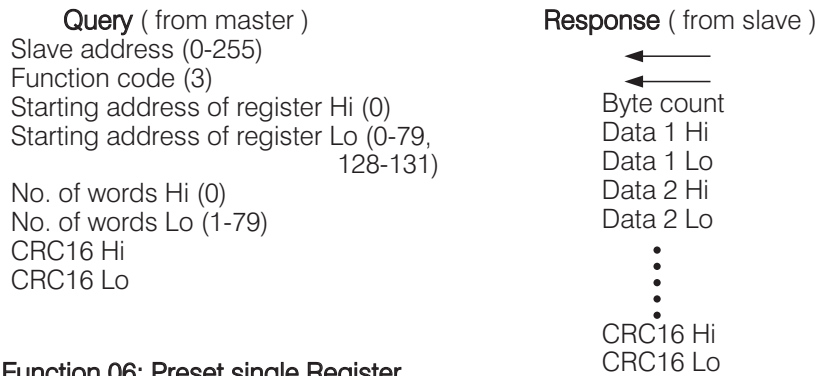

Function 06: Preset single Register

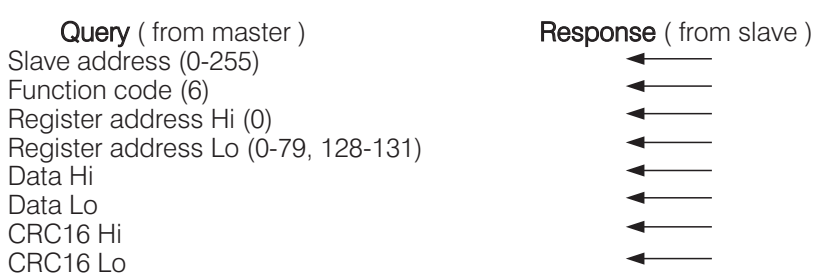

Function 16: Preset Multiple Registers

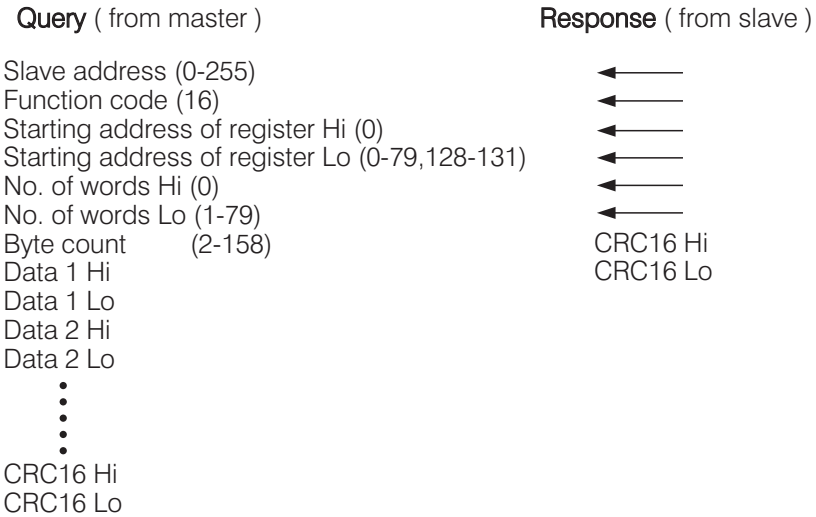

9–2 Exception Responses

If the controller receives a message which contains a corrupted character (parity check error, framing error etc.), or if the CRC16 check fails, the controller ignores the message. However, if the controller receives a syntactically correct message which contains an illegal value, it will send an exception response, consisting of five bytes as follows:
slave address + offset function code + exception code + CRC16 Hi + CRC16 Lo

Where the offset function code is obtained by adding the function code with 128 (ie. function 3 becomes H'83), and the exception code is equal to the value contained in the following table:

Exception Code	Name	Cause
1	Bad function code	Function code is not supported by the controller
2	Illegal data address	Register address out of range
3	Illegal data value	Data value out of range or attempt to write a read-only or protected data

9–3 Parameter Table

Parameter Notation	Register Address	Parameter Description	Data Type ^{*A}	Range ^{*B}		Default Value ^{*C}	Scale ^{*D}		Unit ^{*E}
				Low	High		Low	High	
SP1	0	Set point 1	R/W	SP1L	SP1H	100.0°C (212.0°F)	-19999	45536	PV
TIME	1	Dwell Time	R/W	0	6553.5	0.0	0	65535	minute
A1SP	2	Alarm 1 Set point	R/W	*B1	*B1	100.0°C (212.0°F)	-19999	45536	*E1
A1DV	3	Alarm 1 Deviation Value	R/W	-200.0°C (-360.0°F)	200.0°C (360.0°F)	10.0°C (18.0°F)	-19999	45536	*E1
A2SP	4	Alarm 2 Set point	R/W	*B1	*B1	100.0°C (212.0°F)	-19999	45536	*E2
A2DV	5	Alarm 2 Deviation Value	R/W	-200.0°C (-360.0°F)	200.0°C (360.0°F)	10.0°C (18.0°F)	-19999	45536	*E2
RAMP	6	Ramp Rate	R/W	0	500.0°C (900.0°F)	0.0	0	65535	*E3
OFST	7	Offset Value for P control	R/W	0	100.0	25.0	0	65535	%
REFC	8	Reference Constant for Specific Function	R/W	0	60	2	0	65535	—
SHIF	9	PV1 Shift (offset) Value	R/W	-200.0°C (-360.0°F)	200.0°C (360.0°F)	0.0	-19999	45536	PV1
PB1	10	Proportional Band 1 Value	R/W	0	500.0°C (900.0°F)	10.0°C (18.0°F)	0	65535	PV
TI1	11	Integral Time 1 Value	R/W	0	1000	100	0	65535	Sec
TD1	12	Derivative Time 1 Value	R/W	0	360.0	25.0	0	65535	Sec
CPB	13	Cooling Proportional Band Value	R/W	1	255	100	0	65535	% of PB
DB	14	Heating-Cooling Dead Band	R/W	-36.0	36.0	0	-19999	45536	% of PB
SP2	15	Set point 2	R/W	*B2	*B2	37.8°C (100.0°F)	-19999	45536	PV
PB2	16	Proportional Band 2 Value	R/W	0	500.0°C (900.0°F)	10.0°C (18.0°F)	0	65535	PV
TI2	17	Integral Time 2 Value	R/W	0	1000	100	0	65535	Sec
TD2	18	Derivative Time 2 Value	R/W	0	360.0	25.0	0	65535	Sec
O1HY	19	Output 1 ON-OFF Control Hysteresis	R/W	0.1	55.6°C (100.0°F)	0.1	0	65535	PV
A1HY	20	Hysteresis Control of Alarm 1	R/W	0.1	10.0°C (18.0°F)	0.1	0	65535	*E1
A2HY	21	Hysteresis Control of Alarm 2	R/W	0.1	10.0°C (18.0°F)	0.1	0	65535	*E2
PL1	22	Output 1 Power Limit	R/W	0	100	100	0	65535	%
PL2	23	Output 2 Power Limit	R/W	0	100	100	0	65535	%
FUNC	24	Function Complexity Level	R/W	0 ^{*B3}	1 ^{*B3}	1	0	65535	—
COMM	25	Communication Interface Type	R/W ^{*A1}	0 ^{*B4}	8 ^{*B4}	1	0	65535	—
PROT	26	COMM Protocol Selection	R/W ^{*A1}	0 ^{*B5}	0 ^{*B5}	0	0	65535	—
ADDR	27	Address Assignment of Digital COMM	R/W ^{*A1}	1	255	—	0	65535	—
BAUD	28	Baud Rate of Digital COMM	R/W ^{*A1}	0 ^{*B7}	9 ^{*B7}	5	0	65535	—
DATA	29	Data Bit count of Digital COMM	R/W ^{*A1}	0 ^{*B8}	1 ^{*B8}	1	0	65535	—
PARI	30	Parity Bit of Digital COMM	R/W ^{*A1}	0 ^{*B9}	2 ^{*B9}	0	0	65535	—
STOP	31	Stop Bit Count of Digital COMM	R/W ^{*A1}	0 ^{*B10}	1 ^{*B10}	0	0	65535	—
AOFN	32	Analog Output Function	R/W	0 ^{*B11}	7 ^{*B11}	0	0	65535	—
AOLO	33	Analog Output Low Scale Value	R/W	-19999	45536	0°C (32.0°F)	-19999	45536	*E4
AOHI	34	Analog Output High Scale Value	R/W	-19999	45536	100.0°C (212.0°F)	-19999	45536	*E4
IN1	35	IN1 Sensor Type Selection	R/W	0 ^{*B12}	17 ^{*B12}	1 (0)	0	65535	—
IN1U	36	IN1 Unit Selection	R/W	0 ^{*B13}	2 ^{*B13}	0 (1)	0	65535	—
DP1	37	IN1 Decimal Point Selection	R/W	0 ^{*B14}	3 ^{*B14}	1	0	65535	—
IN1L	38	IN1 Low Scale Value	R/W	-19999	45536	0	-19999	45536	*E5
IN1H	39	IN1 High Scale Value	R/W	-19999	45536	1000	-19999	45536	*E5

Parameter Notation	Register Address	Parameter Description	Data Type ^{*A}	Range ^{*B}		Default Value ^{*C}	Scale ^{*D}		Unit ^{*E}
				Low	High		Low	High	
SP1L	40	SP1 Low Scale Value	R/W	-19999	45536	0°C (32.0°F)	-19999	45536	PV
SP1H	41	SP1 High Scale Value	R/W	-19999	45536	1000.0°C (1832.0°F)	-19999	45536	PV
IN2	42	IN2 Signal Type Selection	R/W	^{*B15} 0	^{*B15} 20	1	0	65535	—
IN2U	43	IN2 Unit Selection	R/W	^{*B13} 0	^{*B13} 2	2	0	65535	—
DP2	44	IN2 Decimal Point Selection	R/W	^{*B14} 0	^{*B14} 3	1	0	65535	—
IN2L	45	IN2 Low Scale Value	R/W	-19999	45536	0	-19999	45536	^{*E6}
IN2H	46	IN2 High Scale Value	R/W	-19999	45536	1000	-19999	45536	^{*E6}
	47								
EIFN	48	Event Input Function	R/W	^{*B16} 0	^{*B16} 9	1	0	65535	—
OUT1	49	Output 1 Function	R/W	^{*B17} 0	^{*B17} 1	0	0	65535	—
O1TY	50	Output 1 Signal Type	R/W	^{*B18} 0	^{*B18} 8	0	0	65535	—
CYC1	51	Output 1 Cycle Time	R/W	0.1	100.0	18.0	0	65535	Sec
O1FT	52	Output 1 Failure Transfer Mode	R/W	^{*B19} -0.1	^{*B19} 100.0	-0.1	-19999	45536	%
OUT2	53	Output 2 Function	R/W	^{*B20} 0	^{*B20} 3	0	0	65535	—
O2TY	54	Output 2 Signal Type	R/W	^{*B18} 0	^{*B18} 8	0	0	65535	—
CYC2	55	Output 2 Cycle Time	R/W	0.1	100.0	18.0	0	65535	Sec
O2FT	56	Output 2 Failure Transfer Mode	R/W	^{*B19} -0.1	^{*B19} 100.0	-0.1	-19999	45536	%
A1FN	57	Alarm 1 Function	R/W	^{*B22} 0	^{*B22} 15	2	0	65535	—
A1MD	58	Alarm 1 Operation Mode	R/W	^{*B23} 0	^{*B23} 3	0	0	65535	—
A1FT	59	Alarm 1 Failure Transfer Mode	R/W	^{*B24} 0	^{*B24} 1	1	0	65535	—
A2FN	60	Alarm 2 Function	R/W	^{*B22} 0	^{*B22} 15	2	0	65535	—
A2MD	61	Alarm 2 Operation Mode	R/W	^{*B23} 0	^{*B23} 3	0	0	65535	—
A2FT	62	Alarm 2 Failure Transfer Mode	R/W	^{*B24} 0	^{*B24} 1	1	0	65535	—
SELF	63	Self Tune Function Selection	R/W	^{*B25} 0	^{*B25} 1	0	0	65535	—
SLEP	64	Sleep mode Function Selection	R/W	^{*B26} 0	^{*B26} 1	0	0	65535	—
PVMD	65	PV Mode Selection	R/W	^{*B27} 0	^{*B27} 3	0	0	65535	—
SP2F	66	Format of Set point 2 Value	R/W	^{*B28} 0	^{*B28} 1	0	0	65535	—
FILT	67	Filter Damping Time Constant of PV	R/W	^{*B29} 0	^{*B29} 9	2	0	65535	—
SPMD	68	Set point Mode Selection	R/W	^{*B30} 0	^{*B30} 5	0	0	65535	—
SEL1	69	Select 1'st Parameter	R/W	^{*B31} 0	^{*B31} 18	0	0	65535	—
SEL2	70	Select 2'nd Parameter	R/W	^{*B31} 0	^{*B31} 18	0	0	65535	—
SEL3	71	Select 3'rd Parameter	R/W	^{*B31} 0	^{*B31} 18	0	0	65535	—
SEL4	72	Select 4'th Parameter	R/W	^{*B31} 0	^{*B31} 18	0	0	65535	—
SEL5	73	Select 5'th Parameter	R/W	^{*B31} 0	^{*B31} 18	0	0	65535	—
	74								
	75								
DRIF	76	Warm-up Drift Calibration Factor	R/W	-5.0°C	5.0°C	—	-19999	45536	°C
AD0	77	A to D Zero Calibration Coefficient	R/W	-360	360	—	-19999	45536	—
ADG	78	A to D Gain Calibration Coefficient	R/W	-199.9	199.9	—	-19999	45536	—
V1G	79	Voltage Input 1 Gain Calibration Coefficient	R/W	-199.9	199.9	—	-19999	45536	—

Parameter Notation	Register Address	Parameter Description	Data Type ^{*A}	Range ^{*B}		Default Value ^{*C}	Scale ^{*D}		Unit ^{*E}
				Low	High		Low	High	
CJTL	80	Cold Junction Low Temperature Calibration Coefficient	R/W	-5.00	40.00	—	-19999	45536	°C
CJG	81	Cold Junction Gain Calibration Coefficient	R/W	-199.9	199.9	—	-19999	45536	—
REF1	82	Reference Voltage 1 Calibration Coefficient for RTD 1	R/W	-199.9	199.9	—	-19999	45536	—
SR1	83	Serial Resistance 1 Calibration Coefficient for RTD 1	R/W	-199.9	199.9	—	-19999	45536	—
MA1G	84	mA Input 1 Gain Calibration Coefficient	R/W	-199.9	199.9	—	-19999	45536	—
REF2	85	Reference Voltage 2 Calibration Coefficient for RTD 2	R/W	-199.9	199.9	—	-19999	45536	—
SR2	86	Serial Resistance 2 Calibration Coefficient for RTD 2	R/W	-199.9	199.9	—	-19999	45536	—
V2G	87	Voltage Input 2 Gain Calibration Coefficient	R/W	-199.9	199.9	—	-19999	45536	—
MA2G	88	mA Input 2 Gain Calibration Coefficient	R/W	-199.9	199.9	—	-19999	45536	—
O2L	89	Output 2 Low Calibration Coefficient	R/W	0	360.0	—	0	65535	—
O2H	90	Output 2 High Calibration Coefficient	R/W	0	900.0	—	0	65535	—
SIG1	91	Point 1 Signal Value of Special Sensor	R/W	-19999	45536	—	-19999	45536	
IND1	92	Point 1 Indication Value of Special Sensor	R/W	-19999	45536	—	-19999	45536	PV
SIG2	93	Point 2 Signal Value of Special Sensor	R/W	-19999	45536	—	-19999	45536	
IND2	94	Point 2 Indication Value of Special Sensor	R/W	-19999	45536	—	-19999	45536	PV
SIG3	95	Point 3 Signal Value of Special Sensor	R/W	-19999	45536	—	-19999	45536	
IND3	96	Point 3 Indication Value of Special Sensor	R/W	-19999	45536	—	-19999	45536	PV
SIG4	97	Point 4 Signal Value of Special Sensor	R/W	-19999	45536	—	-19999	45536	
IND4	98	Point 4 Indication Value of Special Sensor	R/W	-19999	45536	—	-19999	45536	PV
SIG5	99	Point 5 Signal Value of Special Sensor	R/W	-19999	45536	—	-19999	45536	
IND5	100	Point 5 Indication Value of Special Sensor	R/W	-19999	45536	—	-19999	45536	PV
SIG6	101	Point 6 Signal Value of Special Sensor	R/W	-19999	45536	—	-19999	45536	
IND6	102	Point 6 Indication Value of Special Sensor	R/W	-19999	45536	—	-19999	45536	PV
SIG7	103	Point 7 Signal Value of Special Sensor	R/W	-19999	45536	—	-19999	45536	
IND7	104	Point 7 Indication Value of Special Sensor	R/W	-19999	45536	—	-19999	45536	PV
SIG8	105	Point 8 Signal Value of Special Sensor	R/W	-19999	45536	—	-19999	45536	
IND8	106	Point 8 Indication Value of Special Sensor	R/W	-19999	45536	—	-19999	45536	PV
SIG9	107	Point 9 Signal Value of Special Sensor	R/W	-19999	45536	—	-19999	45536	
IND9	108	Point 9 Indication Value of Special Sensor	R/W	-19999	45536	—	-19999	45536	PV
TYPE	109	Signal Type of Special Sensor	R/W	0	3	—	0	65535	—
DATE	110	Manufacturing Date of Product	R	0	3719	—	0	65535	—
NO	111	Serial Number of Product	R	1	999	—	0	65535	—
HOUR	112	Working Hour Value	R	0	65535	—	0	65535	Hour
HRLO	113	Fractional Hour Value	R	0	0.9	—	0	65535	0.1 Hour
ERR1	114	Historical Error Record 1	R/W	0	FFFF	0	0	65535	—
ERR2	115	Historical Error Record 2	R/W	0	FFFF	0	0	65535	—
DELI	116	ASCII Input Delimiter	R/W	0000	007F	000A	0	65535	—
BPL1	117	OUT1 Bumpless Transfer Value	R	0	100.00	—	0	65535	%
BPL2	118	OUT2 Bumpless Transfer Value	R	0	100.00	—	0	65535	%
	119								

Parameter Notation	Register Address	Parameter Description	Data Type ^{*A}	Range ^{*B}		Default Value ^{*C}	Scale ^{*D}		Unit ^{*E}
				Low	High		Low	High	
	120								
	121								
PVHI	122	Historical Maximum Value of PV	R/W	-19999	45536	—	-19999	45536	PV
PVLO	123	Historical Minimum Value of PV	R/W	-19999	45536	—	-19999	45536	PV
	124								
CJCL	125	Sense Voltage of Cold Junction Calibration Low	R	31.680	40.320	—	0	65535	mV
	126								
FILE	127	Default File Selection	R/W	0 ^{*B32}	1 ^{*B32}	—	0	65535	—
PV	128	Current Process Value	R	-19999	45536	—	-19999	45536	PV
SV	129	Current set point Value	R	-19999	45536	—	-19999	45536	PV
MV1	130	Current Output 1 Value	R	0	100.00	—	0	65535	%
MV2	131	Current Output 2 Value	R	0	100.00	—	0	65535	%
ALM	132	Contains Conditional Code of Parameters' Resolution and Current Alarm Status	R	0 ^{*B33}	^{*B33} EF7F	—	0	65535	—
DV	133	Current Deviation (PV-SV) Value	R	-12600	12600	—	-19999	45536	PV
PV1	134	IN1 Process Value	R	-19999	45536	—	-19999	45536	^{*E5}
PV2	135	IN2 Process Value	R	-19999	45536	—	-19999	45536	^{*E6}
PB	136	Current Proportional Band Value	R	0	500.0 °C (900.0 °F)	—	0	65535	PV
TI	137	Current Integral Time Value	R	0	4000	—	0	65535	Sec
TD	138	Current Derivative Time Value	R	0	1440	—	0	65535	Sec
EROR	139	Current Error Code	R	0 ^{*B34}	40 ^{*B34}	—	0	65535	—
PROG	140	Program Identification Code Contains Program Number and Version Number	R	0 ^{*B35}	^{*B35} 15.99	—	0	65535	—
MODE	141	Contains Lockout Status Code and Current System Mode	R	0 ^{*B36}	^{*B36} 3.5	—	0	65535	—
CMND	142	Command Password	R/W	0	65535	—	0	65535	—
JOB	143	Job Password	R/W	0	65535	—	0	65535	—
CJCT	144	Cold Junction Compensation Temperature	R	-40.00 °C	90.00 °C	—	-19999	45536	°C
PVR	145	Current Process Rate Value	R	-16383	16383	—	-19999	45536	PV/min
PVRH	146	Maximum Process Rate Value	R	-16383	16383	—	-19999	45536	PV/min
PVRL	147	Minimum Process Rate Value	R	-16383	16383	—	-19999	45536	PV/min
SPC	148	Current Target Value of set point	R	-19999	45536	—	-19999	45536	PV
	149								
	150								
	151								
	152								
	153								
	154								
	155								
	156								
	157								

Notes:

*A: R/W Specifies a readable / writable data, R specifies a read only data.

*A1: The communication setup data which can't be modified via communication. However these data can be set by using key pad on front panel or via programming port.

*B: The range of some parameters are dependent on the input types. The range of IN1 and IN2 for various input type is shown in the following table:

Input (IN1 or IN2) Range Table

Input Type	J_TC	K_TC	T_TC	E_TC	B_TC	R_TC	S_TC
Range Low	-120°C (-184°F)	-200°C (-328°F)	-250°C (-418°F)	-100°C (-148°F)	0°C (32°F)	0°C (32°F)	0°C (32°F)
Range High	1000°C (1832°F)	1370°C (2498°F)	400°C (752°F)	900°C (1652°F)	1820°C (3308°F)	1767.8°C (3214°F)	1767.8°C (3214°F)

Input Type	N_TC	L_TC	PT.DN	PT.JS	CT	Linear (V, mA) or SPEC
Range Low	-250°C (-418°F)	-200°C (-328°F)	-210°C (-346°F)	-200°C (-328°F)	0 Amp	-19999
Range High	1300°C (2372°F)	900°C (1652°F)	700°C (1292°F)	600°C (1112°F)	90 Amp	45536

*B1: Range of A1SP

If A1FN =	PV1.H, PV1.L	PV2.H,PV2.L	P1.2.H, P1.2.L D1.2.H, D1.2.L
Range of A1SP same as range of	IN1	IN2	IN1, IN2

Range of A2SP

If A2FN =	PV1.H, PV1.L	PV2.H,PV2.L	P1.2.H, P1.2.L D1.2.H, D1.2.L
Range of A2SP same as range of	IN1	IN2	IN1, IN2

Exception: If A1SP or A2SP is configured with respect to CT input, its adjustment range is unlimited.

*B2: Range of SP2

If PVMD =	PV1	PV2	P1-2, P2-1
Range of SP2 same as range of	IN1	IN2	IN1, IN2

Exception: If SP2 is configured with respect to CT input, its adjustment range is unlimited.

*B3, Display symbol and description for FUNC

Parameter Value	Display Symbol	Description
0	BASC	Basic Function Mode
1	FULL	Full Function Mode

*B4, Display symbol and description for COMM

Parameter Value	Display Symbol	Description
0	NONE	No communication function
1	485	RS-485 interface
2	232	RS-232 interface
3	4 - 20	4 - 20 mA analog retransmission output
4	0 - 20	0 - 20 mA analog retransmission output
5	0 - 1V	0 - 1V analog retransmission output
6	0 - 5V	0 - 5V analog retransmission output
7	1 - 5V	1 - 5V analog retransmission output
8	0 - 10V	0 - 10V analog retransmission output

*B5, Display symbol and description for PROT

Parameter Value	Display Symbol	Description
0	RTU	Modbus protocol RTU mode

*B7, Display symbol and description for BAUD

Parameter Value	Display Symbol	Description
0	0.3	0.3 Kbits/s baud rate
1	0.6	0.6 Kbits/s baud rate
2	1.2	1.2 Kbits/s baud rate
3	2.4	2.4 Kbits/s baud rate
4	4.8	4.8 Kbits/s baud rate
5	9.6	9.6 Kbits/s baud rate
6	14.4	14.4 Kbits/s baud rate
7	19.2	19.2 Kbits/s baud rate
8	28.8	28.8 Kbits/s baud rate
9	38.4	38.4 Kbits/s baud rate

*B8, Display symbol and description for DATA

Parameter Value	Display Symbol	Description
0	7BIT	7 data bits
1	8BIT	8 data bits

*B9, Display symbol and description for PARI

Parameter Value	Display Symbol	Description
0	EVEN	Even parity
1	ODD	Odd parity
2	NONE	No parity bit

*B10, Display symbol and description for STOP

Parameter Value	Display Symbol	Description
0	1BIT	One stop bit
1	2BIT	Two stop bits

*B11, Display symbol and description for AOFN

Parameter Value	Display Symbol	Description
0	PV1	Retransmit IN1 process value
1	PV2	Retransmit IN2 process value
2	P1-2	Retransmit IN1-IN2 difference process value
3	P2-1	Retransmit IN2-IN1 difference process value
4	SV	Retransmit set point value
5	MV1	Retransmit output 1 manipulation value
6	MV2	Retransmit output 2 manipulation value
7	DV	Retransmit deviation(PV-SV) Value

*B12, Display symbol and description for IN1

Parameter Value	Display Symbol	Description
0	J_TC	J type thermocouple
1	K_TC	K type thermocouple
2	T_TC	T type thermocouple
3	E_TC	E type thermocouple
4	B_TC	B type thermocouple
5	R_TC	R type thermocouple
6	S_TC	S type thermocouple
7	N_TC	N type thermocouple
8	L_TC	L type thermocouple
9	PT.DN	PT 100 ohms DIN curve
10	PT.JS	PT 100 ohms JIS curve
11	4 - 20	4 - 20 mA linear current input
12	0 -20	0 - 20 mA linear current input
13	0 -1V	0 - 1V linear Voltage input
14	0 - 5V	0 - 5V linear Voltage input
15	1 - 5V	1 - 5V linear Voltage input
16	0 - 10	0 - 10V linear Voltage input
17	SPEC	Special defined sensor curve

*B13, Display symbol and description for IN1U & IN2U

Parameter Value	Display Symbol	Description
0	°C	Degree C unit
1	°F	Degree F unit
2	PU	Process unit

*B14, Display symbol and description for DP1 & DP2

Parameter Value	Display Symbol	Description
0	NO.DP	No decimal point
1	1-DP	1 decimal digit
2	2-DP	2 decimal digits
3	3-DP	3 decimal digits

*B15, Display symbol and description for IN2

Parameter Value	Display Symbol	Description
0	NONE	IN2 no function
1	CT	Current transformer input
4	0 - 1V	0 - 1V linear voltage input
5	0 - 5V	0 - 5V linear voltage input
6	1 - 5V	1 - 5V linear voltage input
7	0 - 10	0 - 10V linear voltage input
20	EIFN	Perform event input function

*B16, Display symbol and description for EIFN

Parameter Value	Display Symbol	Description
0	NONE	Event input no function
1	SP2	SP2 activated to replace SP1
2	PID2	PB2, TI2, TD2 activated to replace PB1, TI1, TD1
3	SP.P2	SP2, PB2, TI2, TD2 activated to replace SP1, PB1, TI1, TD1
4	RS.A1	Reset alarm 1 output
5	RS.A2	Reset alarm 2 output
6	R.A1.2	Reset alarm 1 & alarm 2
7	D.O1	Disable Output 1
8	D.O2	Disable Output 2
9	D.O1.2	Disable Output 1 & Output 2
10	LOCK	Lock all parameters

*B17, Display symbol and description for OUT1

Parameter Value	Display Symbol	Description
0	REVR	Reverse (heating) control action
1	DIRT	Direct (cooling) control action

*B18, Display symbol and description for O1TY & O2TY

Parameter Value	Display Symbol	Description
0	RELY	Relay output
1	SSRD	Solid state relay drive output
2	SSR	Solid state relay output
3	4 - 20	4 - 20 mA current module
4	0 - 20	0 - 20 mA current module
5	0 - 1V	0 - 1V voltage module
6	0 - 5V	0 - 5V voltage module
7	1 - 5V	1 - 5V voltage module
8	0 - 10	0 - 10V voltage module

*B19: Failure transfer mode for output 1 and output 2, select BPLS (bumpless transfer) or 0.0 ~ 100.0 % to continue output 1 and output 2 control function as the unit fails , power starts or manual mode starts.

*B20, Display symbol and description for OUT2

Parameter Value	Display Symbol	Description
0	NONE	Output 2 no function
1	COOL	PID cooling control
2	=AL2	Perform alarm 2 function
3	DCPS	DC power supply module installed

*B21, Display symbol and description for DISF

Parameter Value	Display Symbol	Description
0	PV	Display PV Value
1	SV	Display SV Value

*B22, Display symbol and description for A1FN & A2FN

Parameter Value	Display Symbol	Description
0	NONE	No alarm function
1	TIMR	Dwell timer action
2	DE.HI	Deviation high alarm
3	DE.LO	Deviation low alarm
4	DB.HI	Deviation band out of band alarm
5	DB.LO	Deviation band in band alarm
6	PV1.H	IN1 process value high alarm
7	PV1.L	IN1 process value low alarm
8	PV2.H	IN2 process value high alarm
9	PV2.L	IN2 process value low alarm
10	P1.2.H	IN1 or IN2 process value high alarm
11	P1.2.L	IN1 or IN2 process value low alarm
12	D1.2.H	IN1-IN2 difference process value high alarm
13	D1.2.L	IN1-IN2 difference process value low alarm
14	LB	Loop break alarm
15	SEN.B	Sensor break or A-D fails

*B23, Display symbol and description for A1MD & A2MD

Parameter Value	Display Symbol	Description
0	NORM	Normal alarm action
1	LTCH	Latching alarm action
2	HOLD	Hold alarm action
3	LT.HO	Latching & Hold action

*B24, Display symbol and description for A1FT & A2FT

Parameter Value	Display Symbol	Description
0	OFF	Alarm output OFF as unit fails
1	ON	Alarm output ON as unit fails

*B25, Display symbol and description for SELF

Parameter Value	Display Symbol	Description
0	NONE	Self tune function disabled
1	YES	Self tune function enabled

*B26, Display symbol and description for SLEP

Parameter Value	Display Symbol	Description
0	NONE	Sleep mode function disabled
1	YES	Sleep mode function enabled

*B27, Display symbol and description for PVMD

Parameter Value	Display Symbol	Description
0	PV1	Use PV1 as process value
1	PV2	Use PV2 as process value
2	P1 - 2	Use PV1 - PV2 (difference) as process value
3	P2 - 1	Use PV2 - PV1 (difference) as process value

*B28, Display symbol and description for SP2F

Parameter Value	Display Symbol	Description
0	ACTU	set point 2 (SP2) is an actual value
1	DEVI	set point 2 (SP2) is a deviation value

*B29, Display symbol and description for FILT

Parameter Value	Display Symbol	Description
0	0	0 second time constant
1	0.2	0.2 second time constant
2	0.5	0.5 second time constant
3	1	1 second time constant
4	2	2 seconds time constant
5	5	5 seconds time constant
6	10	10 seconds time constant
7	20	20 seconds time constant
8	30	30 seconds time constant
9	60	60 seconds time constant

*B30, Display symbol and description for SPMD

Parameter Value	Display Symbol	Description
0	SP1.2	Use SP1 or SP2 (depends on EIFN) as set point
1	MIN.R	Use minute ramp rate as set point
2	HR.R	Use hour ramp rate as set point
3	PV1	Use IN1 process value as set point
4	PV2	Use IN2 process value as set point
5	PUMP	Selected for pump control

*B31, Display symbol and description for SEL1 ~ SEL5

Parameter Value	Display Symbol	Description
0	NONE	No parameter put ahead
1	TIME	Parameter TIME put ahead
2	A1.SP	Parameter A1SP put ahead
3	A1.DV	Parameter A1DV put ahead
4	A2.SP	Parameter A2SP put ahead
5	A2.DV	Parameter A2DV put ahead
6	RAMP	Parameter RAMP put ahead
7	OFST	Parameter OFST put ahead
8	REFC	Parameter REFC put ahead
9	SHIF	Parameter SHIF put ahead
10	PB1	Parameter PB1 put ahead
11	TI1	Parameter TI1 put ahead
12	TD1	Parameter TD1 put ahead
13	C.PB	Parameter CPB put ahead
14	DB	Parameter DB put ahead
15	SP2	Parameter SP2 put ahead
16	PB2	Parameter PB2 put ahead
17	TI2	Parameter TI2 put ahead
18	TD2	Parameter TD2 put ahead

*B32, Display symbol and description for FILE

Parameter Value	Display Symbol	Description
0	0	Perform default setting by using °C FILE
1	1	Perform default setting by using °F FILE

*B33, Description of ALM Value

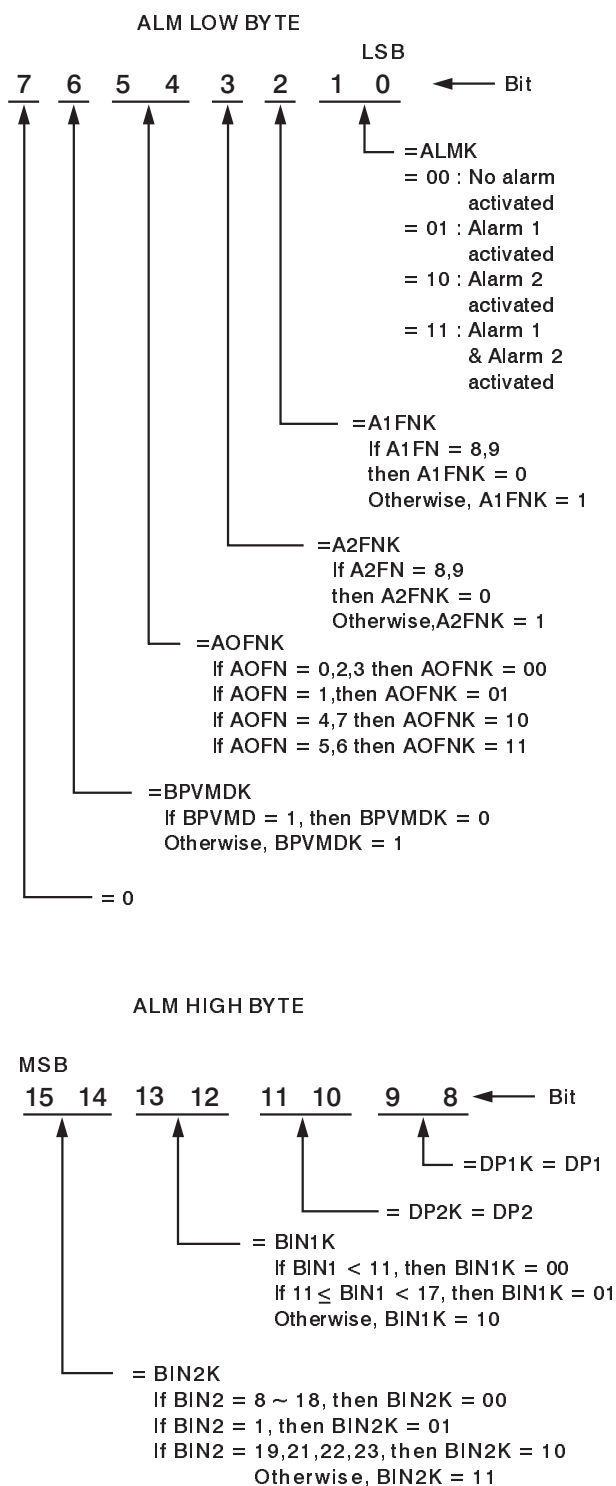

*B34, Error messages

Error Code	Display Symbol	Error Description	Corrective Action
1	Er01	Illegal setup values used: PV1 is used for both PVMD and SPMD that is meaningless for control.	Check and correct setup values of PVMD and SPMD, PV and SV can't use the same value for normal control
2	Er02	Illegal setup values used: PV2 is used for both PVMD and SPMD that is meaningless for control	Same as error code 1
3	Er03	Illegal setup values used: P1-2 or P2-1 is used for PVMD while PV1 or PV2 is used for SPMD. Dependent values are used for PV and SV will produce incorrect result of control	Check and correct setup values of PVMD and SPMD. Difference of PV1 and PV2 can't be used for PV while PV1 or PV2 is used for SV
4	Er04	Illegal setup values used: COOL is used for OUT2, but DIRT (cooling action) is already used for OUT1 or PID mode is not used for OUT1 (that is PB1 or PB2 =0, and TI1 or TI2 =0)	Check and correct setup values of OUT2, PB1, PB2, TI1, TI2 and OUT1. IF OUT2 is required for cooling control, the control should use PID mode (PB ≠ 0, TI ≠ 0) and OUT1 should use reverse mode (heating action), otherwise, don't use OUT2 for cooling control
5	Er05	Illegal setup values used: unequal IN1U and IN2U or unequal DP1 and DP2 while P1-2 or P2-1 is used for PVMD or, PV1 or PV2 is used for SPMD or, P1.2.H, P1.2.L, D1.2.H or D1.2.L are used for A1FN or A2FN.	Check and correct setup values of IN1U, IN2U, DP1, DP2, PVMD, SPMD, A1FN or A2FN. Same unit and decimal point should be used if both PV1 and PV2 are used for PV, SV, alarm1 or alarm 2.
6	Er06	Illegal setup values used: OUT2 select =AL2 but A2FN select NONE	Check and correct setup values of OUT2 and A2FN. OUT2 will not perform alarm function if A2FN select NONE.
7	Er07	Illegal setup values used: Dwell timer (TIMR) is selected for both A1FN and A2FN.	Check and correct setup values of A1FN and A2FN. Dwell timer can only be properly used for single alarm output.

Error Code	Display Symbol	Error Description	Corrective Action
9	Er09	Communication error: receive error due to parity error, framing error, overrun error, receive buffer full error, frame check-sum error or receive disturbed	<ol style="list-style-type: none"> 1. Correct the communication software to meet the protocol requirements 2. Add a terminating resistor to the multi-drop link (RS-485) to minimize the noise. 3. Use twisted pair wire for RS-485 interface connection to minimize the noise. 4. Check the polarity of RS-485 interface connection.
10	Er10	Communication error: bad function code	Correct the communication software to meet the protocol requirements.
11	Er11	Communication error: register address out of range	Don't issue an over-range address of register to the slave.
12	Er12	Communication error: access a non-existent parameter	Don't issue a non-existent parameter to the slave.
14	Er14	Communication error: attempt to write a read only data	Don't write a read only data or a protected data to the slave.
15	Er15	Communication error: write a value which is out of range to a register	Don't write an over-range data to the slave register.
17	Er17	Computing error: Illegal (unnormalized) floating point data	Software bug. Return to factory for repair.
18	Er18	Computing error: Arithmetic result overflow or underflow	Software bug. Return to factory for repair.
19	Er19	Computing error: divided by zero	Don't use an equal value for AOLO and AOHI.
20	Er20	Computing error: Illegal BCD data entry	Software bug. Return to factory for repair.
21	Er21	Timing error: A to D conversion data error due to overrun	A to D converter doesn't work properly. Return to factory for repair.
22	Er22	Timing error: check-sum error received during multi-chip communication procedure	<ol style="list-style-type: none"> 1. Correct the multi-chip communication software to meet the protocol requirement. 2. Return to factory for repair.
23	Er23	Timing error: wrong function code received during multi-chip communication procedure	<ol style="list-style-type: none"> 1. Correct the multi-chip communication software to meet the protocol requirement. 2. Return to factory for repair.

26	<i>RtEr</i>	Fail to perform auto-tuning function	<ol style="list-style-type: none"> The PID values obtained after auto-tuning procedure are out of range. Retry auto-tuning. Don't change set point value during auto-tuning procedure. Don't change Event input state during auto-tuning procedure. Use manual tuning instead of auto-tuning.
27	<i>CRER</i>	Incorrect calibration procedure or tolerance of analog component too big to meet specified accuracy	<ol style="list-style-type: none"> Pay more attention to the calibration procedures. Return to factory for repair.
28	<i>CnPE</i>	Memory comparison error, different value detected in the EEPROM and mapped RAM	<ol style="list-style-type: none"> Check and correct the wiring and grounding problems to minimize the system noise. Return to factory for repair.
29	<i>EEPE</i>	EEPROM can't be written correctly	Return to factory for repair.
32	<i>CJEr</i>	Cold junction compensation device(s) malfunction	Return to factory for repair.
33	<i>KYEr</i>	Key switch shorted or related PCB circuit shorted	Return to factory for repair.
34	<i>LLLL2</i>	Input 2 (IN2) signal too low	<ol style="list-style-type: none"> Check if the input 2 sensor used is accordant with IN2 type selection. Check the connection polarity of input 2 sensor. Replace input 2 sensor.
35	<i>HHH2</i>	Input 2 (IN2) signal too high	<ol style="list-style-type: none"> Check if the input 2 sensor used is accordant with IN2 type selection. Replace input 2 sensor.
36	<i>LLL1</i>	Input 1 (IN1) signal too low	<ol style="list-style-type: none"> Check if the input 1 sensor used is accordant with IN1 type selection. Check the connection polarity of input 1 sensor. Replace input 1 sensor.
37	<i>HHH1</i>	Input 1 (IN1) signal too high	<ol style="list-style-type: none"> Check if the input 1 sensor used is accordant with IN1 type selection. Replace input 1 sensor.

Error Code	Display Symbol	Error Description	Corrective Action
38	<i>Sb2E</i>	Input 2 (IN2) sensor break, or input 2 current below 1 mA if 4-20 mA is selected, or input 2 voltage below 0.25V if 1 - 5V is selected	Replace input 2 sensor.
39	<i>Sb1E</i>	Input 1 (IN1) sensor break, or input 1 current below 1 mA if 4-20 mA is selected, or input 1 voltage below 0.25V if 1 - 5V is selected	Replace input 1 sensor.
40	<i>RdEr</i>	A to D converter or related component(s) malfunction	Return to factory for repair.

*B35, PROG code description

Parameter Value	Specified product
0.XX	BTC-2500 controller
1.XX	BTC-9300 controller
2.XX	L91 controller
3.XX	BTC-8300 controller
4.XX	BTC-4300 controller

XX indicates the program version

*B36, Display symbol and description for MODE

Parameter Value	Description
X.0	Perform normal mode
X.1	Enter calibration mode
X.2	Enter auto-tuning mode
X.3	Enter failure mode
X.4	Enter manual mode
X.5	Enter sleep mode
0.X	Unlock condition
1.X	SP1, SEL1 – SEL5 are unlocked
2.X	Lock all parameters except SP1
3.X	All parameters are locked

*C: The parameters are preset with the default values specified in the table during production.

*D: The scale values specify the transformation relation between the value of parameter and the value of register. The parameter with a scale low value is stored in the register with a number zero. The parameter with a scale high value is stored in the register with a number 65535. For example, if a value R is read from the addressed register, and LS = scale low value, HS = scale high value, then

$$\text{the value of the parameter} = \text{LS} + \text{R} \times \frac{(\text{HS} - \text{LS})}{65535}$$

Similarly, before writing the value of parameter to the addressed register, the value W of the parameter must be transformed according to the following formula :

$$(\text{W} - \text{LS}) \times \frac{65535}{(\text{HS} - \text{LS})}$$

Note that the value stored in the register is always positive value.

*E: The unit PV means that the unit of parameter is the same as the unit of PV (process value). The unit of PV is determined by PVMD, IN1, IN2, IN1U, and IN2U.

*E1: Unit determination for A1SP, A1DV and A1HY

If A1FN = Unit same as unit of	DE.HI, DE.LO DB.HI, DB.LO	PV1.H PV1.L	PV2.H PV2.L	P1.2.H, P1.2.L D1.2.H, D1.2.L
	PV	PV1	PV2	PV1, PV2

*E2: Unit determination for A2SP, A2DV and A2HY

If A2FN = Unit same as unit of	DE.HI, DE.LO DB.HI, DB.LO	PV1.H PV1.L	PV2.H PV2.L	P1.2.H, P1.2.L D1.2.H, D1.2.L
	PV	PV1	PV2	PV1, PV2

*E3: Unit determination for RAMP

Unit =	SPMD = MIN.R	SPMD = HR.R
	PV / Minute	PV / Hour

*E4: Unit determination for AOLO and AOHI

If AOFN = Same unit as unit of	PV1	PV2	P1-2 P2-1	SV	MV1 MV2
	PV1	PV2	PV1, PV2	PV	%

*E5: Unit is the same as unit of PV1 (IN1)

*E6: Unit is the same as unit of PV2 (IN2)

9-4 Communication Examples

Example 1: Preset 9 multiple registers

01	10	00	00	00	09	18	52	07	00	00	52	07	
Addr.	Func.	Starting Addr.		No. of words		Bytes	SP1=100.0		TIME=0.0		A1SP=100.0		
4E	83	52	07	4E	83	00	00	00	FA	00	02	Hi	Lo
A1DV=10.0		A2SP=100.0		A2DV=10.0		RAMP=0.0		OFST=25.0		REFC=2		CRC16	

Example 2: Read PV, SV, MV1 and MV2.

Send the following message to the controller via the COMM port or programming port:

	03	00	H'80	00	04	Hi	Lo
Addr.	Func.	Starting Addr.		No. of words		CRC16	

Example 3: Perform Reset Function (same effect as pressing key)

Query

	06	00	H'8E	H'68	H'25	Hi	Lo
Addr.	Func.	Register Addr.	Data Hi/Lo		CRC16		

Example 4: Enter Auto-tuning Mode

Query

	06	00	H'8E	H'68	H'28	Hi	Lo
Addr.	Func.	Register Addr.	Data Hi/Lo		CRC16		

Example 5: Enter Manual Control Mode

Query

	06	00	H'8E	H'68	H'27	Hi	Lo
Addr.	Func.	Register Addr.	Data Hi/Lo		CRC16		

Example 6: Read All Parameters

Query

	03	00	00	00	H'50	Hi	Lo
Addr.	Func.	Starting Addr.		No. of words		CRC16	

Example 7: Modify the Calibration Coefficient

Preset the CMND register with 26665 before attempting to change the calibration coefficient.

	06	00	H'8E	H'68	H'29	Hi	Lo
Addr.	Func.	Starting Addr.		No. of words		CRC16	

A-1 Menu Existence Conditions

Menu Existence Conditions Table

Menu	Parameter Notation	Existence Conditions
User Menu	SP1	Exists unconditionally
	TIME	Exists if A1FN selects TIMR or A2FN selects TIMR
	A1SP	Exists if A1FN selects PV1H, PV1L, PV2H, PV2L, P12H, P12L, D12H or D12L
	A1DV	Exists if A1FN selects DEHI, DELO, DBHI, or DBLO
	A2SP	Exists if A2FN selects PV1H, PV1L, PV2H, PV2L, P12H, P12L, D12H or D12L
	A2DV	Exists if A2FN selects DEHI, DELO, DBHI, or DBLO
	RAMP	Exists if SPMD selects MINR or HRR
	OFST	Exists if T11 is used for control (depends on Event input and EIFN selection) but $T11 = 0$ and $PB1 \neq 0$ or if T12 is used for control (depends on Event input and EIFN selection) but $T12 = 0$ and $PB2 \neq 0$
	REFC	Exists if SPMD selects PUMP
	SHIF PB1	Exists unconditionally
	T11 TD1	Exists if $PB1 \neq 0$
	CPB, DB	Exists if OUT2 select COOL
	SP2	Exists if EIFN selects SP2 or SPP2, or if SPMD selects PUMP
	PB2	Exists if EIFN selects PID2 or SPP2
	T12 TD2	Exists if EIFN selects PID2 or SPP2 provided that $PB2 \neq 0$
	O1HY	If PID2 or SPP2 is selected for EIFN, then O1HY exists if $PB1 = 0$ or $PB2 = 0$. If PID2 or SPP2 is not selected for EIFN, then O1HY exists if $PB1 = 0$
	A1HY	Exists if A1FN selects DEHI, DELO, PV1H, PV1L, PV2H, PV2L, P12H, P12L, D12H, or D12L
	A2HY	Exists if A2FN selects DEHI, DELO, PV1H, PV1L, PV2H, PV2L, P12H, P12L, D12H, or D12L
	PL1	If PID2 or SPP2 is selected for EIFN, then PL1 exists if $PB1 \neq 0$ or $PB2 \neq 0$. If PID2 or SPP2 is not selected for EIFN, then PL1 exists if $PB1 \neq 0$
	PL2	Exists if OUT2 selects COOL

Menu Existence Conditions Table (continued 2/3)

Menu	Parameter Notation	Existence Conditions
Setup Menu	FUNC	Exists unconditionally
	COMM	Exists if FUNC selects FULL
	PROT ADDR BAUD DATA PARI STOP	Exists if COMM selects 485 or 232
	AOFN	Exists if COMM selects 4-20, 0-20, 0-1V, 0-5V, 1-5V, or 0-10
	AOLO AOHI	Exists if COMM selects 4-20, 0-20, 0-1V, 0-5V, 1-5V, or 0-10 and AOFN is not MV1 and MV2
	IN1 IN1U DP1	Exists unconditionally
	IN1L IN1H	Exists if IN1 selects 4-20, 0-20, 0-1V, 0-5V, 1-5V, or 0-10
	IN2	Exists if FUNC selects FULL
	IN2U DP2 IN2L IN2H	Exists if IN2 selects 4-20, 0-20, 0-1V, 0-5V, 1-5V, or 0-10
	OUT1 O1TY CYC1 O1FT OUT2	Exists unconditionally
	O2TY CYC2 O2FT	Exists if OUT2 selects COOL

Menu Existence Conditions Table (continued 3/3)

Menu	Parameter Notation	Existence Conditions
Setup Menu	A1FN	Exists unconditionally
	A1MD	Exists if A1FN selects DEHI, DELO, DBHI, DBLO, PV1H, PV1L, PV2H, PV2L, P12H, P12L, D12H, D12L, LB or SENB
	A1FT	Exists if A1FN is not NONE
	A2FN	Exists unconditionally
	A2MD	Exists if A2FN selects DEHI, DELO, DBHI, DBLO, PV1H, PV1L, PV2H, PV2L, P12H, P12L, D12H, D12L, LB or SENB
	A2FT	Exists if A2FN is not NONE
	EIFN PVMD FILT	Exists if FUNC selects FULL
	SELF	Exists unconditionally
	SLEP SPMD	Exists if FUNC selects FULL
	SP1L SP1H	Exists unconditionally
	SP2F	Exists if EIFN selects SP2 or SPP2, or if SPMD selects PUMP
	SEL1 SEL2 SEL3 SEL4 SEL5	Exists unconditionally

A-2 Factory Menu Description

Parameter Notation	Display Format	Parameter Description	Range		Default Value
EROR	<i>ErOR</i>	Current Error Code	Low: 0	High: 40	—
PROG	<i>PrOG</i>	Program Identification Code Contains Program Number and Version Number	Low: 0	High: 15.99	—
MODE	<i>mOdE</i>	Contains Lockout Status Code and Current System Mode	Low: 0	High: 3.5	—
CMND	<i>Cmnd</i>	Command Password	Low: 0	High: 65535	—
JOB	<i>Job</i>	Job Password	Low: 0	High: 65535	—
DRIF	<i>d---</i>	Warm-up Drift Calibration Factor	Low: -5.0°C	High: 5.0°C	—
AD0	<i>Ad0</i>	A to D Zero Calibration Coefficient	Low: -360	High: 360	—
ADG	<i>AdG</i>	A to D Gain Calibration Coefficient	Low: -199.9	High: 199.9	—
V1G	<i>V1G</i>	Voltage Input 1 Gain Calibration Coefficient	Low: -199.9	High: 199.9	—
CJTL	<i>CJtL</i>	Cold Junction Low Temperature Calibration Coefficient	Low: -5.00 °C	High: 40.00 °C	—
CJG	<i>CJG</i>	Cold Junction Gain Calibration Coefficient	Low: -199.9	High: 199.9	—
REF1	<i>rEF.1</i>	Reference Voltage 1 Calibration Coefficient for RTD 1	Low: -199.9	High: 199.9	—
SR1	<i>Sr.1</i>	Serial Resistance 1 Calibration Coefficient for RTD 1	Low: -199.9	High: 199.9	—
MA1G	<i>mA1G</i>	mA Input 1 Gain Calibration Coefficient	Low: -199.9	High: 199.9	—
V2G	<i>V2G</i>	Voltage Input 2 Gain Calibration Coefficient	Low: -199.9	High: 199.9	—
SIG1*	<i>SIG1</i>	Point 1 Signal Value of Special Sensor	Low: -19999	High: 45536	—
IND1*	<i>IND1</i>	Point 1 Indication Value of Special Sensor	Low: -19999	High: 45536	—
SIG2*	<i>SIG2</i>	Point 2 Signal Value of Special Sensor	Low: -19999	High: 45536	—
IND2*	<i>IND2</i>	Point 2 Indication Value of Special Sensor	Low: -19999	High: 45536	—
SIG3*	<i>SIG3</i>	Point 3 Signal Value of Special Sensor	Low: -19999	High: 45536	—
IND3*	<i>IND3</i>	Point 3 Indication Value of Special Sensor	Low: -19999	High: 45536	—
SIG4*	<i>SIG4</i>	Point 4 Signal Value of Special Sensor	Low: -19999	High: 45536	—
IND4*	<i>IND4</i>	Point 4 Indication Value of Special Sensor	Low: -19999	High: 45536	—
SIG5*	<i>SIG5</i>	Point 5 Signal Value of Special Sensor	Low: -19999	High: 45536	—
IND5*	<i>IND5</i>	Point 5 Indication Value of Special Sensor	Low: -19999	High: 45536	—
SIG6*	<i>SIG6</i>	Point 6 Signal Value of Special Sensor	Low: -19999	High: 45536	—
IND6*	<i>IND6</i>	Point 6 Indication Value of Special Sensor	Low: -19999	High: 45536	—
SIG7*	<i>SIG7</i>	Point 7 Signal Value of Special Sensor	Low: -19999	High: 45536	—
IND7*	<i>IND7</i>	Point 7 Indication Value of Special Sensor	Low: -19999	High: 45536	—
SIG8*	<i>SIG8</i>	Point 8 Signal Value of Special Sensor	Low: -19999	High: 45536	—
IND8*	<i>IND8</i>	Point 8 Indication Value of Special Sensor	Low: -19999	High: 45536	—
SIG9*	<i>SIG9</i>	Point 9 Signal Value of Special Sensor	Low: -19999	High: 45536	—
IND9*	<i>IND9</i>	Point 9 Indication Value of Special Sensor	Low: -19999	High: 45536	—
TYPE*	<i>TYPE</i>	Signal Type of Special Sensor	Low: 0	High: 3	—
DATE	<i>DATE</i>	Manufacturing Date of Product	Low: 0	High: 3719	—
NO	<i>NO</i>	Serial Number of Product	Low: 1	High: 999	—

* These parameters are available only if IN1 selects SPEC.

Parameter Notation	Display Format	Parameter Description	Range		Default Value
HOUR	<i>Hour</i>	Working Hour Value	Low: 0	High: 65535 Hours	—
HRLO	<i>HrLo</i>	Fractional Hour Value	Low: 0	High: 0.9 Hour	—
ERR1	<i>Err1</i>	Historical Error Record 1	Low: 0	High: FFFF	0
ERR2	<i>Err2</i>	Historical Error Record 2	Low: 0	High: FFFF	0
DELI	<i>dELI</i>	ASCII Input Delimiter	Low: 0000	High: 007F	000A
BPL1	<i>bPL1</i>	OUT1 Bumpless Transfer Value	Low: 0	High: 100.00 %	—
BPL2	<i>bPL2</i>	OUT2 Bumpless Transfer Value	Low: 0	High: 100.00 %	—
CJCL	<i>CJCL</i>	Sense Voltage of Cold Junction Calibration Low	Low: 31.680	High: 40.320 mV	—

A-3 Glossary

Absolute zero: The lowest theoretical temperature. At absolute zero, a body would have no molecular motion of heat energy. Absolute zero is the zero point on the Rankine and Kelvin scale. (-273.15 °C or -459.67 °F)

AC: Alternating Current; an electric current that reverses direction at regularly occurring intervals.

Accuracy

Calibration accuracy: The potential error of a device compared to a physical constant or agency standard.

Control accuracy: Maintaining a process at the desired setting. The errors or combination of errors in the entire system including the sensor, control, power, load and design inefficiencies affect control accuracy.

Display accuracy: The amount of potential error between a measured value and the control's displayed value.

Set point accuracy: The potential error between a measured value and the control setting.

Alarm: A control condition or function, indicating that the process is a predetermined amount above or below the set point.

Alpha (α): The average percent change in resistance per degree of a pure metal resistance device between 0° and 100 °C. Usually designated by the Greek letter alpha, α with units of ohm/ohm/°C. The common alpha for a platinum RTD is 0.00385 ohm/ohm/°C.

Ambient compensation: The design of an instrument such that changes in ambient temperature do not affect the readings of the instrument.

Ambient temperature: The average or mean temperature of the surrounding air which comes in contact with the equipment and instruments under test.

Ampere (amp): A unit used to define the rate of flow of electricity (current) in a circuit; units are one coulomb (6.25×10^{18} electrons) per second.

Analog indication: A meter with graduated scale and a pointer that moves to indicate process condition.

Analog output: A voltage or current signal that is a continuous function of the measure parameter.

Analog set point: Potentiometer adjustment of the control setting.

ANSI: American National Standards Institute

Anti-reset windup: This is a feature in a three-mode PID controller which prevents the integral (auto reset) circuit from functioning when the temperature is outside the proportional band.

ASME: American Society of Mechanical Engineers.

ASTM: American Society for Testing and Materials.

Automatic reset (Integral): The integral function of a control that automatically compensates for the difference between the set point and the actual process temperature. A signal moves the proportional band up or down to correct for the droop or offset error.

Automatic tuning (of control parameters): A control that calculates the optimum PID parameters with a built-in software algorithm to eliminate manual tuning efforts.

AWG: American Wire Gauge.

Bandwidth: A symmetrical region around the set point in which proportional control occurs.

Baud rate: In serial communications, the rate of information transfer in bits per second.

Blackbody: A theoretical object that radiates the maximum amount of energy at a given temperature, and absorbs all the energy incident upon it. A blackbody is not necessarily black. (The name blackbody was chosen because the color black is defined as the total absorption of light [energy].)

Boiling point: The temperature at which a substance in the liquid phase transforms to the gaseous phase; commonly refers to the boiling point of water which is 100 °C (212 °F) at sea level.

Btu: British Thermal Unit. The quantity of thermal energy required to raise one pound of water 1 °F at or near its maximum density (39.1 °F).

Bumpless transfer: The smooth, automatic transition from automatic control (closed loop) to manual control (open loop). The control output is maintained during the transfer.

Burst proportioning: A fast-cycling output form on a time proportioning controller (typically adjustable from .2 to 4 seconds) used in conjunction with a solid state relay to prolong the life of heaters by minimizing thermal stress.

Calender-van Dusen equation: An equation that defines the resistance-temperature value of any pure metal that takes the form of $R_T = R_0 (1 + AT + BT^2)$ for values between the ice point (0 °C) and the freezing point of antimony (630.7 °C) and the form $R_T = R_0 [1 + AT + BT^2 + C(T-100)T^2]$ between the oxygen point (-183.0 °C) and the ice point (0 °C).

Calibration: The process of adjusting an instrument so that the indication is accurate compared to the actual value.

Calorie: The quantity of thermal energy required to raise one gram of water 1 °C at 15 °C.

Cascade: Control in which the output of a secondary or inner control loop is the set point for a primary or outer loop. The primary loop, in turn, determines the control action.

CE: A mark that designates compliance with European Union (EU) requirements for products sold in Europe.

Celsius: (Centigrade) A temperature scale with 0 °C defined as the ice point and 100°C as the boiling point of water at sea level.

cfm: The volumetric flow rate of a liquid or gas in cubic feet per minute.

Chatter: The rapid cycling on and off of a relay in a control process due to insufficient bandwidth in the controller.

Closed loop control: A control system in which process temperature changes are detected by a sensor. The feedback from the sensor allows the control make adjustments for accurate system regulation.

Cold junction compensation: A temperature sensitive device that prevents changes in the ambient temperature from affecting the cold junction of a thermocouple.

Common mode rejection ratio: The ability of an instrument to reject interference from a common voltage at the input terminals with relation to ground. Expressed in dB (decibels).

Control loop: The basic control loop of any automatic control system consists of:

- 1) variable (process)
- 2) sensor
- 3) error detector (of control)
- 4) control
- 5) final control element (relay, SSR, SCR)
- 6) temperature indication

Control mode: The method in which the control restores the system temperature to set point. On/Off, proportional, and PID are the most common control modes.

CT: Current Transformer

Current proportioning: A 4-20 milliamp (typical) current output which provides a current proportional to the amount of control required.

Current transformer: A transformer, intended for measuring purposes, designed to generate a current at its secondary winding which is proportional to the current at the primary winding.

Cycle time: The time usually expressed in seconds for a controller to complete one on/off cycle.

Data logging: Recording a process variable over an extended period of time.

DC: Direct Current; An electric current flowing in one direction and constant in value.

Dead band: 1. For chart recorders: the minimum change of input signal required to cause a deflection in the pen position. 2. For temperature controllers: the temperature band where heat is turned off upon rising temperature and turned on upon falling temperature expressed in degrees. The area where no heating (or cooling) takes place.

Default parameters: The parameters, or programmed instructions, permanently stored in microprocessor software to provide a data base.

Derivative: (See Rate)

Deviation: The difference between the value of the controlled variable and the value at which it is being controlled.

Deviation alarm: An offset value that follows the set point. If the set point is 350 °F and the Deviation alarm value is +20 °F, the alarm value would be 350 °F plus 20 °F (or 370 °F), See Process alarm.

Dielectric strength: An amount of voltage that an insulating material can withstand before an electrical breakdown occurs.

Differential: In an on/off control, the temperature difference expressed in degrees between where the control switches off and the control switches on.

Differential control: A controller can control one process in relation to the difference of a second process.

DIN: Deutsche Industrial Norms. A German agency that sets engineering and dimensional standards that now has worldwide recognition.

Drift: A change in a value over a long period due to changes in factors such as ambient temperature, time or line voltage.

Droop: In time proportioning controls, the difference in temperature between the set point and where the system temperature stabilizes. Corrected by automatic or manual reset.

Dual output: The primary output will regulate the process temperature. A secondary output will be utilized for process cooling or as an alarm.

Duty cycle: Percentage of "load ON time" relative to total cycle time.

Efficiency: The amount of useful output versus energy input.

Electrical interference: Electrical noise induced upon the signal wires that obscures the wanted information signal.

Electromagnetic Compatibility (EMC): A system meets three requirements: 1. It does not cause interference with other systems, 2. It is not susceptible to emissions from other systems and 3. It does not cause interference with itself.

Electromagnetic interference (EMI): An electrical and magnetic noise which can be generated when switching inductive devices, lightning, radio wave radiation, electrostatic discharge etc.

emf: Electromotive force. A rise in (electrical) potential energy. The principal unit is the volt.

Emissivity: The ratio of energy emitted by an object to the energy emitted by a blackbody at the same temperature. The emissivity of an object depends upon its material and surface texture; a polished metal surface can have an emissivity around 0.2, and a piece of wood can have an emissivity around 0.95.

Endothermic: Absorbs heat. A process is said to be endothermic when it absorbs heat.

Error: The difference between the correct or desired value and the actual reading or value taken.

Event input: A programmable On/Off input used to signal peripheral equipment or a process.

Event output: A programmable On/Off output used to signal peripheral equipment or a process.

Exothermic: Gives off heat. A process is said to be exothermic when it releases heat.

Fahrenheit: A temperature scale with 32°F defined as the ice point and 212°F as the boiling point of water at sea level.

Filter: A low pass filter designed to minimize display fluctuations.

Flow rate: speed or velocity of fluid movement.

FM: Factory Mutual Research Corp. An organization which sets industrial safety standards.

FM-approved: An instrument that meets a specific set of specifications established by Factory Mutual Research Corp.

Form A: Single Pole Single Throw relay that only utilizes the N.O. and common contacts. These contacts close when the relay coil is energized. The contacts open when power is removed from the control.

Form B: Single Pole Single Throw relay that only utilizes the N.C. and common contacts. These contacts will open when the relay coil is energized. The contacts will close when power is removed from the control.

Form C: Single Pole Double Throw. Utilizes the N.O., N.C. and common contacts. The user has the option of wiring for a Form A or Form B contact. Refer to the Form A and Form B above for more information.

fpm: Flow velocity in feet per minute.

fps: Flow velocity in feet per second.

Freezing point: The temperature at which the substance goes from the liquid phase to the solid phase.

Frequency: The number of event occurrences or cycles over a specified period of time.

Fuse: A device that interrupts power in a circuit when an overload occurs.

Fuzzy logic: An artificial intelligence technique that allows control decisions to be made upon approximate or incomplete information. Fuzzy logic is a continuous decision making function that can prevent initial overshoot and set point differentials.

Gain: The amount of amplification used in an electrical circuit.

GIGA: The prefix for one billion (G).

gph: The volumetric flow rate in gallons per hour.

gpm: The volumetric flow rate in gallons per minute.

Ground: 1. The electrical neutral line having the same potential as the surrounding earth. 2. The negative side of dc power supply. 3. Reference point for an electrical system.

Grounded junction: A thermocouple junction in which the sheath and conductors are welded together forming a completely sealed integrated junction.

Heat: Thermal energy expressed in Calories, Btu's or Joules.

Heat of fusion: The amount of energy required to change one pound of a material from a solid to a liquid without an increase in temperature. Expressed in Btu/lb.

Heat of vaporization: The amount of energy required to change one pound of a material from a liquid to a vapor without an increase in temperature. Expressed in Btu/lb.

Heat sink: 1. Thermodynamic. A body which can absorb thermal energy. 2 Practical. A finned piece of metal used to dissipate the heat of solid state components mounted on it.

Heat transfer: The process of thermal energy flowing from a body of high energy to a body of low energy. Means of transfer are: Conduction, the two bodies in contact; Convection, a form of conduction where the two bodies in contact are of different phases, i.e; solid and gas; Radiation, all bodies emit infrared radiation

Heat treating: A process for treating metals where heating to a specific temperature and cooling at a specific rate changes the properties of the metal.

Hertz (Hz): Unit in which frequency is expressed. Synonymous with cycles per second.

Hi-Pot test : To apply a high voltage to an electrical conductor to test the surrounding insulation.

Hysteresis: In ON/OFF control, the temperature change necessary to change the output from full ON to full OFF.

Hunting: Oscillation or fluctuation of process temperature between set point and process variable.

IAE: Integrated absolute error

Ice point: The temperature at which pure water freezes. 0°C, 32°F, 273.16K.

IE: Integrated error

Impedance: The total opposition in a circuit to the flow of electrical current. Measured in ohms and represented by "Z".

Infrared: Or radiation is the exchange of energy by electromagnetic waves. The infrared spectrum extends from the deep red end of the visible spectrum to the microwave region of the radio spectrum, the portion adjacent to the visible spectrum is of importance to heating. Radiant heat transfer can be very efficient in directing energy from the heat source to an object.

Integral: (See Automatic Reset).

Interchangeability error: A measurement error that can occur if two or more probes are used to make the same measurement. It is caused by a slight variation in characteristics of different probes.

Intrinsically safe: An instrument which will not produce any spark or thermal effects under normal or abnormal conditions that will ignite a specified gas mixture.

IPTS-68: International Practical Temperature Scale of 1968. Fixed points in thermometry set by the 1968 General Conference of Weights and Measures.

ISA: Instrument Society of America.

ISE: Integrated squared error

Isolation: Electrical Separation

Isothermal: A process or area that maintains a constant temperature.

ITS-90: International Temperature Scale of 1990

Joule : The basic unit of thermal energy. 1 Joule equals 1 ampere passed through a resistance of 1 ohm for 1 second.

Junction: A thermocouple junction is the point at which two alloys are joined. A typical thermocouple circuit would have a measuring and a reference junction.

Kelvin: The unit of absolute or thermodynamic temperature scale. Zero Kelvin is absolute zero, where all molecular activity stops. No "°" symbol is used. 0 °C= 273.15K; 100 °C =373.15K.

Kilo: The prefix for one thousand (K).

Kilowatt (kw): 1000 watts or 3412Btu per hour.

Lag: 1. A time delay between the output of a signal and the response of the instrument to which the signal is sent. 2. A time relationship between two waveforms where a fixed reference point on one wave occurs after the same point of the reference wave.

Least Significant Digit (LSD): The digit farthest to the right in a display.

Linearity: The deviation of an instrument's response from a straight line.

Load: The electrical demand of a process expressed as power (watts), current (amps) or resistance (ohms).

Manual reset: The adjustment on a proportional control which shifts the proportional band in relation to the set point to eliminate droop of offset errors.

Maximum operating temperature: The maximum temperature at which an instrument or sensor can be safely operated.

Maximum power rating: The maximum power in watts that a device can safely handle.

Measuring junction: The thermocouple junction referred to as the hot junction that is used to measure an unknown temperature.

Mechanical relay: An electromechanical device that completes or breaks a circuit by opening or closing electrical contacts.

Mega: The prefix for one million (M) (10^6).

Melting point: The temperature at which a substance transforms from a solid phase to a liquid phase.

Mico: The prefix for one millionth (10^{-6}).

Microamp: 10^{-6} amps (one millionth of an amp).

Micron: 10^{-6} meters (one millionth of a meter).

Microprocessor: The central processing unit (CPU) that performs the logic operations in a micro-computer system. The microprocessor in a process or instrument control decodes instructions from the stored program, performs algorithmic and logic functions, and produces signals and commands.

Milli: The prefix for one thousandth (10^{-3})

Milliamp: 10^{-3} amps (one thousandth of an amp).

Millivolt: 10^{-3} volts (one thousandth of a volt).

NEC: National Electrical Code

NEMA: National Electrical Manufacturer's Association

NEMA 4X: A front panel rating designating the control as washdown capable and corrosion resistance.

NIST: National Institute of Standards and Technology, United States Department of Commerce.

Noise: Undesirable electrical interference on the signal wires.

Noise suppression: A device used to reduce electrical interference.

Normal-mode rejection ratio: The ability of an instrument to reject interference usually of line frequency (50-60 Hz) across its input terminals.

NPT: National Pipe Thread.

Offset: The difference in temperature between the set point and the actual process temperature. Also, referred to as droop.

ohm: The unit of electric resistance.

On/off controller: A controller whose action is fully on or fully off.

Open Loop Control: A control system with no sensing feedback.

Overshoot: Excursion of temperature above the set point.

Phase: A time-based relationship between a periodic function and a reference. In electricity, it is expressed in angular degrees to describe the voltage or current relationship of two alternating waveforms.

Phase proportioning: A form of temperature control where the power supplied to the process is controlled by limiting the phase angle of the line voltage.

PID: Three mode temperature control – proportional, integral, (automatic reset), derivative(rate).

Polarity: In electricity, the quality of having two oppositely charged poles, one positive and one negative.

Potentiometer: 1. A variable resistor often used to control a circuit. 2. A balancing bridge used to measure voltage.

Primary standard (NBS): The standard reference units and physical constants maintained by the National Bureau of Standards upon which all measurement units in the United States are based.

Process alarm: A fixed alarm or secondary set point value independent of the primary set point. Should a process value exceed this value, an alarm condition would register.

Process variable: The parameter being controlled or measured such as temperature, relative humidity, flow, level, pressure, etc.

Proportional band: A temperature band in degrees within which a control's proportioning function is active.

Proportional control mode: When process temperature approaches set point and enters the proportional band, the output is switched on and off at the established cycle time. The change in power to the load provides a throttling action which results in less temperature overshoot.

Ramp: A programmed rise or fall in temperature at a constant rate.

Range: An area between two limits in which a measurement or control action takes place. Typically expressed in upper and lower limits.

Rankine (°R): An absolute temperature scale based upon the Fahrenheit scale with 180° between the ice point and boiling point of water. 459.69°R=0°F.

Rate (derivative): A control function that measures the rate of increase or decrease of the system temperature and brings the control into an accelerated proportioning action. This mode prevents an overshoot condition at initial heat-up and with system disturbances.

Rate time: The interval over which the system temperature is sampled for the derivative function.

Reference junction: The cold junction in a thermocouple circuit which is held at a stable known temperature. The standard reference temperature is 0°C (32°F); however, other temperatures can be used.

Relay (mechanical): An electromechanical device that completes or interrupts a circuit by physically moving electrical contacts into contact with each other.

Relay (solid state): A solid state switching device which completes or interrupts a circuit electrically with no moving parts.

Repeatability: The ability of a probe or instrument to give the same output or reading under repeated identical conditions.

Resistance: The resistance to the flow of electric current measured in ohms (Ω). For a conductor resistance is a function of diameter, resistivity (an intrinsic property of the material) and length.

Resolution sensitivity: The amount of temperature change that must occur before the control actuates. It may be expressed in temperature or as a percentage of the control's scale.

Response time (Time constant): The time required by a sensor to reach 63.2% of a step change in temperature under a specified set of conditions. Five time constants are required for the sensor to stabilize at 99.3 % of the step change value.

Retransmit output: Analog output scaled to the process or the set point value.

RFI: Radio frequency interference.

RS232 or RS485 output signal: A serial interface suitable for connection between a digital control and a personal computer, a host computer or printer.

RTD: A temperature sensing probe of finely wound platinum wire that displays a linear resistance change for a corresponding temperature change. The resistance increases as the temperature rises. A base resistance of 100 ohms at 32°F is the industry (DIN) standard.

Saturation temperature: The boiling temperature of a liquid at the existing pressure.

SCFM: Volumetric flow rate in cubic feet per minute at 60 °F (15°C) and standard atmospheric pressure.

SCR: Silicone Controlled Rectifier

Secondary standard: A standard of unit measurement derived from a primary standard.

Sensitivity: The minimum change in input signal to which an instrument can respond.

Set point: Control setting to achieve or maintain temperature.

Sheath thermocouple: A thermocouple made out of mineral-insulated thermocouple cable which has an other metal sheath.

Shield: Material surrounding a conductor(s) to prevent electrostatic or EMI from external sources.

Slide wire feedback: A potentiometer that varies the resistance to control a valve position.

Soak: To raise the temperature of a metal object in a heated environment to produce a metallurgical change.

Soft start: Reduces voltage on initial start-up which reduces power to the heaters. If heater has accumulated moisture internally during a shut down, soft start will allow heater to dry before full voltage is applied so as to extend heater life.

Solid State Relay (SSR): A solid state switching device which completes or breaks a circuit electrically with no moving parts.

Span: The difference between the upper and lower limits of a range expressed in the same units as the range.

Specific gravity: The ratio of mass of any material to the mass of the same volume of pure water at 4°C.

Specific Heat: The ratio of thermal energy required to raise the temperature of a particle 1 degree to the thermal energy required to raise an equal mass of water 1 degree.

SSR: Solid state relay (see relay, solid state).

Stability: The ability of an instrument or sensor to maintain a constant output when a constant input is applied.

Surge current: A current of short duration occurring when power is initially applied to capacitive or resistive loads, usually lasting no more than several cycles.

Temperature gradient: The range of temperature variations at various physical locations throughout a thermal system.

Tera: The prefix for one trillion (T).

Thermal expansion: An increase in size due to an increase in temperature expressed in units of an increase in length or increase in size per degree, i.e., inches/inch/degree C.

Thermal lag: The time delay in the distribution of heat throughout a thermal system.

Thermal system: A regulated environment consisting of a heat source, heat transfer medium, sensing device and a process variable control instrument.

Thermistor: A temperature sensing probe made of a mixture of metal oxides and encapsulated in epoxy or glass. A large change in resistance is exhibited proportional to a change in temperature. The resistance usually decreases as temperature rises.

Thermocouple: A temperature sensing probe consisting of the junction of two dissimilar metals which has a millivolt output proportional to the difference in temperature between the "hot" junction and the lead wires (cold junction).

Thermocouple break protection: Fail-safe operation that assures output shutdown upon an open thermocouple condition.

Thermowell: A closed-end tube designed to protect temperature sensors from harsh environments, high pressure, and flows. They can be installed into a system by pipe thread or welded flange and are usually made of corrosion-resistant metal or ceramic material depending upon the application.

Transducer: A device which converts the parameter being measured into another form which is its output. For example, a thermocouple transforms heat into a millivolt output.

Transmitter (two-wire): A device which is used to transmit temperature data from either a thermocouple or RTD via a two-wire current loop. The loop has an external power supply and the transmitter acts as a variable resistor with respect to its input signal.

Triac: A solid state switching device used to switch alternating current wave forms.

Triple point (water): The thermodynamic state where all three phases, solid, liquid, and gas may all be present in equilibrium. The triple point of water is at .01°C.

TTL: Transistor-to-transistor logic. A form of solid state logic which uses only transistors to form the logic gates.

UL: Underwriters Laboratories, Inc. An independent laboratory that establishes standards for commercial and industrial products.

Ultraviolet: That portion of the electromagnetic spectrum below blue light (380 nanometers).

Undershoot: Excursion of temperature below set point.

Ungrounded junction: A thermocouple junction fully insulated from the sheath.

Viscosity: The inherent resistance of a substance to flow

Volt: The (electrical) potential difference between two points in a circuit. The fundamental unit is derived as work per unit charge — ($V=W/Q$). One volt is the potential difference required to move one coulomb of charge between two points in a circuit while using one joule of energy.

Voltage: An electrical potential which is measured in volts.

VPFW SSR: A type of Solid State Relay with Variable Period and Full Wave switching characteristics.

Wattage: A measurement of electrical power. In a resistive circuit, $VI=W$ (See Ohms Law formulas).

Working standard: A standard of unit measurement calibrated from either a primary or secondary standard which is used to calibrate other devices or make comparison measurements.

Zero voltage switching: The making or breaking of circuit timed such that the transition occurs when the voltage waveform crosses zero voltage; typically it is only found in solid state switching devices.

A-4 Index

- A1DV: 11, 13, 18, 47, 48, 50, 51, 53, 54, 110
- A1FN: 11, 16, 17, 20, 42, 43, 47, 48, 49, 50, 51, 52, 53, 54, 56, 70, 71, 72, 83, 86, 90, 91, 94, 95, 105
- A1FT: 11, 17, 56, 86
- A1HY: 11, 13, 47, 48, 49, 50, 51, 52, 53, 54, 94
- A1MD: 11, 16, 17, 47, 48, 49, 50, 51, 52, 53, 54, 70, 94
- A1SP: 11, 13, 18, 20, 47, 48, 49, 50, 51, 52, 53, 54, 70, 83, 94
- A2DV: 11, 13, 18, 45, 48, 50, 51, 53, 54
- A2FN: 11, 17, 20, 42, 43, 45, 47, 48, 50, 51, 52, 53, 54, 56, 71, 72, 105
- A2FT: 11, 17, 56
- A2MD: 11, 17, 45, 47, 48, 50, 51, 52, 53, 54
- A2SP: 11, 13, 18, 20, 45, 48, 50, 51, 52, 53, 54
- AD0: 11, 18
- Adaptive: 5
- ADDR: 11, 14, 40, 76, 97, 98, 105
- ADG: 11, 18
- Alarm 1: 7, 9, 13, 16, 17, 34, 40, 47, 48, 49, 50, 51, 52, 53, 56, 68, 70, 71, 91, 94, 105, 107
- Alarm 2: 7, 9, 13, 16, 17, 35, 40, 47, 48, 49, 50, 51, 52, 53, 54, 56, 68, 71, 72, 105, 107, 108
- AOFN: 11, 14, 40, 77, 99
- AOHI: 11, 14, 40, 77, 92, 99
- AOLO: 11, 14, 40, 77, 92, 99
- Auto-tune: 4, 9, 40
- Auto-tuning: 11, 12, 43, 45, 46, 58, 59, 60, 61, 68, 70, 81, 86, 89, 91, 94, 97, 98, 105, 108
- Automatic calibration: 100, 103
- Automatic programming: 4, 8
- Baud: 14, 76, 108
- BAUD: 11, 14, 40, 76, 97, 98
- BC-Net: 7, 96, 97, 98, 100
- Bumpless transfer: 4, 40, 43, 56, 57, 65
- Calibration mode: 8, 12, 56, 57, 100, 101
- Chamber: 90, 91, 100, 103
- CJCT: 11, 19, 66
- CJG: 11, 19
- CJTL: 11, 18
- Colour codes: 25
- COMM: 5, 11, 13, 14, 40, 76, 77, 83, 92, 97, 98, 99
- Communication: 4, 5, 7, 13, 37, 40, 76, 98, 105, 108
- Contactors: 28, 30, 32, 34, 35, 84, 87, 104
- Control: 4, 5, 6, 7, 8, 9, 11, 12, 13, 15, 16, 18, 21, 22, 23, 24, 25, 39, 40, 41, 42, 43, 44, 45, 53, 55, 56, 57, 58, 59, 60, 61, 62, 65, 66, 67, 68, 69, 70, 72, 73, 74, 75, 77, 78, 80, 81, 82, 84, 85, 86, 87, 88, 89, 90, 91, 92, 93, 94, 96, 97, 98, 99, 100, 101, 102, 104, 105, 106, 108
- Cooling control: 16, 105, 108
- CPB: 11, 13, 18, 37, 42, 45, 46, 75, 89, 90
- DB: 11, 13, 42, 45, 46, 51, 76, 89, 107, 108, 110
- Critical steady state: 62
- CT: 4, 20, 22, 28, 40, 52, 67, 102
- Current transformer: 7, 15, 28, 52, 67
- CYC1: 11, 16, 43, 45, 52, 67, 85, 86, 89
- CYC2: 11, 16, 45, 67, 85
- DATA: 11, 14, 40, 76, 97, 98
- DC power supply: 4, 16, 40, 64
- Dead band: 13, 43, 44, 46
- Default: 8, 9, 11, 12, 13, 14, 15, 16, 17, 18, 19, 40, 58, 59, 67, 78, 79
- Deviation alarm: 45, 50
- Deviation band alarm: 51
- Differential control: 4, 74, 93, 108
- Digital filter: 4, 40, 78, 108
- Display mode: 9, 11, 12, 40, 66, 74, 93
- DP1: 11, 15, 40, 41, 71, 72, 73, 74, 77, 83, 86, 87, 89, 90, 93, 99, 105
- DV: 11, 13, 18, 19, 42, 45, 47, 48, 50, 51, 53, 54, 66
- Dwell timer: 4, 16, 40, 43, 47, 56, 71, 72, 86, 91, 105, 108
- EIFN: 11, 17, 18, 29, 37, 40, 48, 68, 69, 70, 76, 80, 81, 83, 90, 91, 94, 95
- Error code: 47, 48, 50, 51, 72, 73, 74, 104, 105
- Event input: 4, 7, 12, 17, 29, 37, 40, 48, 58, 60, 65, 68, 69, 70, 72, 76, 90, 94, 105, 107
- Exception mode: 12
- Failure mode: 12, 54, 56, 57, 58, 65, 108
- Failure transfer: 16, 17, 40, 56, 75, 101

FILT: 11, 17, 40, 78, 80, 81, 83, 108
 Flow: 4, 11, 61, 62
 Freezer: 54, 88, 90
 FUNC: 9, 11, 13, 40, 73, 74, 76, 77, 79, 80, 83, 86, 87, 89, 92, 93, 94, 95, 97, 98, 99
 Furnace: 52, 94, 95
 Fuzzy logic: 4, 5, 108
 Fuzzy + PID: 4
 Heat-cool control: 40, 45, 88
 Heater break: 4, 7, 40, 52
 Heater current: 28, 52, 67
 Humidity: 99, 109
 Idle state: 80
 IN1: 11, 14, 15, 16, 18, 19, 20, 40, 41, 54, 71, 72, 73, 74, 77, 82, 83, 86, 87, 88, 89, 93, 99, 105
 IN1H: 11, 15, 41, 54, 73, 74, 83, 93
 IN1L: 11, 15, 41, 54, 73, 74, 83, 93
 IN1U: 11, 15, 40, 41, 71, 72, 73, 74, 77, 83, 86, 87, 89, 90, 93, 99, 105
 IN2: 11, 14, 15, 16, 18, 19, 20, 40, 52, 67, 73, 74, 77, 83, 92, 93, 105
 IN2H: 11, 15, 40, 73, 74, 92, 93
 IN2L: 11, 15, 40, 73, 74, 92, 93
 IN2U: 11, 15, 40, 73, 74, 77, 93, 105
 Input 1: 3, 7, 8, 18, 19, 26, 27, 40, 41, 56, 66, 73, 74, 77, 101, 102, 105, 107
 Input 2: 7, 19, 26, 27, 40, 52, 56, 66, 67, 73, 74, 77, 92, 102, 105, 107
 Installation: 21, 23, 24, 98
 Inverter: 38, 82, 90, 91
 Keys and displays: 9
 Level: 4, 12, 13, 40, 48, 50, 51, 52, 68, 84, 93
 Linear current: 15, 26, 27, 31, 33, 41
 Linear DC input wiring: 26
 Linear output: 43, 45, 52, 67, 107, 108
 Linear voltage: 15, 26, 27, 31, 33, 41
 Lockout: 4, 8, 40, 81, 101, 107
 Loop break: 4, 16, 40, 53, 56, 58, 108
 Loop break alarm: 4, 16, 40, 53, 108
 MA1G: 11, 19
 MA2G: 11, 19
 Manual control (hand control mode): 9, 40, 57, 58, 65, 75, 97, 98, 108
 Manual tuning: 43, 45, 60, 61, 105
 Menu overview: 11
 Mini jumper and DIP switch: 8
 Mold: 88, 95
 Mounting: 21
 MV1: 19, 53, 56, 57, 65, 66, 68, 75, 77, 108
 MV2: 19, 56, 57, 65, 66, 68, 75, 77, 108
 O1FT: 11, 16, 56, 57, 83, 86, 89
 O1HY: 11, 13, 43, 44, 45, 87
 O1TY: 11, 15, 16, 41, 43, 45, 67, 83, 85, 86, 87, 89, 93
 O2FT: 11, 16, 56, 57, 89
 O2TY: 11, 16, 41, 45, 67, 85, 89
 OFST: 11, 13, 18, 42, 43, 45
 On-off control: 13, 43, 44, 45, 56, 58, 59, 60, 65, 75, 87
 Ordering code: 7, 64, 77
 OUT1: 11, 15, 22, 41, 43, 44, 45, 65, 75, 82, 83, 85, 86, 87, 88, 89, 90, 92, 93, 105
 OUT2: 11, 16, 22, 41, 45, 48, 50, 51, 53, 54, 56, 57, 64, 65, 75, 82, 83, 85, 88, 89, 90, 105
 Output 1: 7, 9, 13, 14, 15, 16, 17, 19, 30, 40, 41, 43, 45, 56, 57, 65, 66, 67, 68, 75, 82, 85, 87, 101, 107, 108
 Output 2: 7, 9, 13, 14, 16, 17, 19, 32, 40, 41, 45, 50, 56, 57, 64, 65, 66, 67, 68, 75, 82, 85, 101, 107, 108
 Oven: 5, 69, 86, 91, 92, 104
 Parameter description: 3, 13, 14, 15, 16, 17, 18, 19
 PARI: 5, 11, 14, 40, 76, 85, 97, 98, 108
 PB: 11, 19, 46, 58, 60, 62, 66, 105, 108
 PB1: 11, 13, 17, 18, 42, 43, 45, 46, 56, 58, 59, 61, 62, 65, 68, 70, 75, 81, 83, 87, 94, 95, 105
 PB2: 11, 13, 17, 18, 40, 42, 46, 58, 59, 62, 65, 68, 70, 94, 95, 105
 P(or PD) control: 4, 12, 13, 18, 40, 43, 57, 65, 80, 81
 PID adjustment: 62, 63
 PID control: 5, 6, 40, 43, 44, 45, 58, 59, 60, 68, 91
 PL1: 11, 13, 40, 43, 75, 83, 94, 95
 PL2: 11, 13, 40, 75
 Power wiring: 23
 Pressure: 4, 41, 69, 80, 81, 82, 108
 Process alarm: 45, 48, 49
 Programming port: 5, 8, 39, 103, 108
 PROT: 4, 11, 13, 40, 76, 97, 98
 Pulsed voltage: 7, 30, 32, 41, 84, 85, 107
 Pump/pressure control: 4, 18, 40, 80, 81, 82, 108

PVHI: 9, 11, 19, 66
 PV1: 11, 13, 17, 19, 20, 40, 41, 45, 48, 49, 55, 56, 66, 70, 73, 74, 77, 78, 80, 83, 92, 93, 94, 95, 99, 105, 108
 PV1 shift: 13, 40, 55
 PV2: 11, 17, 19, 20, 48, 52, 56, 66, 67, 73, 74, 77, 92, 93, 105, 108
 PVLO: 9, 11, 19, 66
 PVMD: 11, 17, 20, 40, 56, 73, 74, 80, 83, 92, 93, 94, 95, 105
 PVR: 11, 19, 66
 PVRH: 11, 19, 66
 PVRL: 11, 19, 66
 RAMP: 11, 13, 18, 40, 42, 71, 72, 90, 91, 94, 95
 Ramp: 4, 13, 18, 40, 42, 58, 59, 69, 71, 72, 90, 91, 94, 95, 97, 98, 108
 Ramp & Dwell: 71, 72, 90
 Rearrange user menu: 42
 Recorder: 5, 38, 99
 REF1: 11, 19, 102
 REFC: 11, 13, 18, 42, 80, 81, 83
 Refrigerator: 87
 Relay: 4, 7, 15, 30, 32, 34, 35, 40, 41, 43, 45, 47, 68, 69, 70, 84, 90, 91, 104, 107, 108
 Reload default value: 40, 67
 Remote lockout: 4, 40, 81, 107
 Remote set point: 4, 40, 58, 59, 73, 92, 108
 Retransmission: 4, 5, 7, 13, 38, 40, 77, 92, 99, 108
 RS-232: 4, 5, 7, 13, 36, 37, 69, 76, 96, 98, 108
 RS-485: 4, 5, 7, 13, 36, 76, 77, 96, 108
 RTD input wiring: 26
 Second PID: 40, 68, 69, 70, 94, 95
 Second set point: 69, 107
 SEL1: 4, 8, 11, 18, 42
 SEL2: 8, 11, 18, 42
 SEL3: 11, 18, 42
 SEL4: 11, 18, 42
 SEL5: 4, 8, 11, 18, 42
 SELF: 11, 17, 43, 45, 58, 80, 83, 86, 89
 Self-tune: 4, 40, 58
 Self-tuning: 43, 45, 46, 58, 61, 68, 108
 Sensor installation guidelines: 24
 Sensor break: 4, 16, 40, 54, 56, 57, 58, 105, 107, 108
 Sensor break alarm : 4, 40, 54, 57, 108
 Setup menu: 4, 8, 11, 12, 48, 54, 58, 68, 69, 73, 74, 76, 77, 78, 79, 80, 83, 86, 89, 92, 93, 94, 95, 97, 98, 99
 SHIF: 11, 13, 18, 42, 55
 Sleep mode: 4, 9, 12, 17, 40, 58, 79, 108
 SLEP: 9, 11, 17, 40, 79, 83
 Smart network adaptor: 7, 96
 SNA10A: 7, 36, 76
 SNA10B: 7, 36, 76, 96, 97, 100
 Soft-start: 4
 SP1: 8, 13, 17, 18, 40, 43, 44, 45, 47, 48, 49, 50, 51, 54, 68, 69, 71, 72, 74, 75, 80, 86, 89, 90, 91, 92, 93, 94, 95, 99
 SP1H: 11, 13, 18, 54, 83, 87, 99
 SP1L: 11, 13, 18, 54, 83, 87, 99
 SP1 range: 40, 54
 SP2: 11, 13, 17, 18, 20, 40, 42, 48, 68, 69, 72, 74, 80, 81, 83, 90, 91, 95
 SP2F: 11, 18, 40, 69, 80, 83
 SPMD: 11, 18, 40, 56, 68, 69, 71, 72, 73, 74, 80, 83, 90, 91, 92, 93, 94, 95, 105
 SR1: 11, 19, 102
 SSR: 4, 7, 30, 31, 32, 33, 40, 41, 43, 45, 67, 84, 85, 108
 SSRD: 40, 41, 43, 45, 67, 85
 STOP: 11, 14, 40, 76, 97, 98
 System modes: 12
 TD: 11, 19, 37, 63, 66
 TD1: 11, 13, 17, 18, 42, 43, 45, 58, 59, 61, 62, 68, 70, 81, 83, 94, 95
 TD2: 11, 13, 17, 18, 40, 42, 58, 59, 62, 68, 70, 94, 95
 Thermocouple input wiring: 25
 TI: 11, 19, 58, 60, 63, 66, 105
 TI1: 11, 13, 17, 18, 42, 43, 45, 53, 59, 61, 62, 68, 70, 81, 83, 94, 95, 105
 TI2: 11, 13, 17, 18, 40, 42, 58, 59, 62, 68, 70, 94, 95, 105
 TIME: 11, 13, 18, 42, 43, 47, 53, 54, 71, 72, 86, 90, 91, 95
 Triac: 4, 7, 30, 31, 32, 33, 108
 User menu: 4, 8, 9, 11, 12, 42, 48, 71, 75, 80, 83, 87, 94, 95
 Ultimate p band: 62
 Ultimate period: 62
 Unpacking: 21
 V1G: 11, 18
 V2G: 11, 19
 Valve control: 93
 VPFW SSR: 84, 85
 Water tank: 93

A-5 Memo

Use the following Table as a master copy for your settings.

Contained in	Parameter Notation	Display Format	Your setting	Contained in	Parameter Notation	Display Format	Your setting
User Menu	SP1			Setup Menu	COMM	Coññ	
	TIME	t, ñE			PROT	Prot	
	A1SP	A 1SP			ADDR	Addr	
	A1DV	A 1dY			BAUD	bAud	
	A2SP	A 2SP			DATA	dAtA	
	A2DV	A 2dY			PARI	PAr,	
	RAMP	rAñP			STOP	StoP	
	OFST	oFSt			AOFN	AoFn	
	REFC	rEFc			AOLO	AoLo	
	SHIF	SH, F			AOHI	AoH,	
	PB1	Pb 1			IN1	, n 1	
	TI1	t, 1			IN1U	, n 1u	
	TD1	td 1			DP1	dP 1	
	CPB	CPb			IN1L	, n 1L	
	DB	db			IN1H	, n 1H	
	SP2	SP2			IN2	, n 2	
	PB2	Pb 2			IN2U	, n 2u	
	TI2	t, 2			DP2	dP 2	
	TD2	td 2			IN2L	, n 2L	
	O1HY	o 1HY			IN2H	, n 2H	
	A1HY	A 1HY			OUT1	out 1	
	A2HY	A 2HY			O1TY	o 1tY	
	PL1	PL 1			CYC1	CYc 1	
PL2	PL 2		O1FT	o 1Ft			
Setup Menu	FUNC	Func					

Contained in	Parameter Notation	Display Format	Your setting
Setup Menu	OUT2	<i>out2</i>	
	O2TY	<i>o2ty</i>	
	CYC2	<i>CYC2</i>	
	O2FT	<i>o2ft</i>	
	A1FN	<i>A1Fn</i>	
	A1MD	<i>A1nd</i>	
	A1FT	<i>A1ft</i>	
	A2FN	<i>A2Fn</i>	
	A2MD	<i>A2nd</i>	
	A2FT	<i>A2ft</i>	
	EIFN	<i>E1Fn</i>	
	PVMD	<i>PVnd</i>	
	FILT	<i>F, Lt</i>	
	SELF	<i>SELF</i>	
	SLEP	<i>SLEP</i>	
	SPMD	<i>SPnd</i>	
	SP1L	<i>SP 1L</i>	
	SP1H	<i>SP 1H</i>	
	SP2F	<i>SP2F</i>	
	DISF	<i>d, SF</i>	
	SEL1	<i>SEL 1</i>	
	SEL2	<i>SEL 2</i>	
	SEL3	<i>SEL 3</i>	
	SEL4	<i>SEL 4</i>	
	SEL5	<i>SEL 5</i>	

Contained in	Parameter Notation	Display Format	Your setting
Calibration Mode Menu	AD0	<i>Ad0</i>	
	ADG	<i>AdG</i>	
	V1G	<i>V 1G</i>	
	CJTL	<i>CJtL</i>	
	CJG	<i>CJG</i>	
	REF1	<i>rEF. 1</i>	
	SR1	<i>Sr. 1</i>	
	MA1G	<i>nA 1G</i>	
	V2G	<i>V 2G</i>	
	MA2G	<i>nA 2G</i>	
Display Mode Menu	PVHI	<i>PVHi</i>	
	PVLO	<i>PVLo</i>	
	MV1	<i>H _ _ _</i>	
	MV2	<i>[_ _ _</i>	
	DV	<i>dV</i>	
	PV1	<i>PV 1</i>	
	PV2	<i>PV 2</i>	
	PB	<i>Pb</i>	
	TI	<i>t, i</i>	
	TD	<i>t d</i>	
	CJCT	<i>CJct</i>	
	PVR	<i>PVr</i>	
	PVRH	<i>PVr.H</i>	
	PVRL	<i>PVr.L</i>	

A– 6 Warranty

WARRANTY

Brainchild Electronic Co. is pleased to offer suggestions on the use of its various products. However, Brainchild makes no warranties or representations of any sort regarding the fitness for use, or the application of its products by the Purchaser. The selection, application or use of Brainchild products is the Purchaser's responsibility. No claims will be allowed for any damages or losses, whether direct, indirect, incidental, special or consequential. Specifications are subject to change without notice. In addition, Brainchild reserves the right to make changes – without notification to Purchaser – to materials or processing that do not affect compliance with any applicable specification. Brainchild products are warranted to be free from defects in material and workmanship for two years after delivery to the first purchaser for use. An extended period is available with extra cost upon request. Brainchild's sole responsibility under this warranty, at Brainchild's option, is limited to replacement or repair, free of charge, or refund of purchase price within the warranty period specified. This warranty does not apply to damage resulting from transportation, alteration, misuse or abuse.

RETURNS

No products return can be accepted without a completed Return Material Authorization (RMA) form.

***BrainChild* Electronic Co., Ltd.**

No.209, Chung Yang Rd., Nan Kang Dist., Taipei, Taiwan, R.O.C.

Tel: 886-2-27861299

Fax: 886-2-27861395

web site: <http://www.brainchild.com.tw>
