

# User Manual

## Protocol Converter PC-E, Serial to Ethernet (RS232/485 Modbus RTU to Modbus TCP/IP)

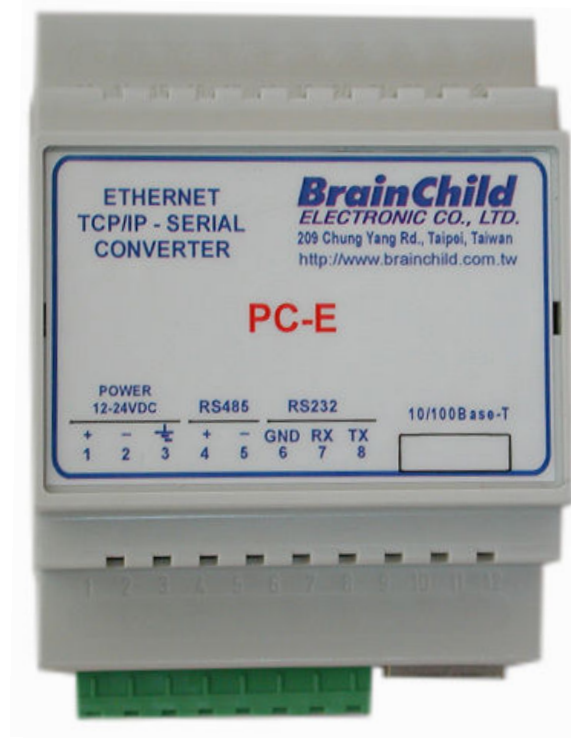

## ***COPYRIGHT NOTICE***

**This manual is a publication of Brainchild Electronics Co... Ltd. and is provided for use by its customers only. The contents of the manual are copyrighted by Brainchild Electronics; reproduction in whole or in part, for use other than in support of Brainchild Electronics equipment, is prohibited without the specific written permission from Brainchild Electronics**

## ***SERVICE***

**If service is required then pack the unit in its original packaging container or, if unavailable, any suitable rigid container. If a substitute container is used, surround the unit with shock absorbing material; damage in shipment is not covered by the warranty. Include a letter with the unit describing the difficulty of usage and request Brainchild for RMA procedure.**

**Send the equipment to the following address:**

**Brainchild Electronic. Co. Ltd  
6F, 209, Chung yong Road, Nan Kang Dist, Taipei, Taiwan, R.O.C  
Tel: +886-2-27861299  
Fax: +886-2-27861395  
Email: sales@brainchild.com.tw**

**All returns will be tested to verify customer claims of noncompliance with the product warranty. Improper return packaging, which makes verification impossible, will void the warranty. If noncompliance is verified and is not due to customer abuse or the other exceptions described with product warranty, Brainchild Electronics will, at its option, repair or replace the Product returned to it, freight prepaid, which fail to comply with the foregoing warranty, provided Brainchild is notified of such noncompliance within the one-year warranty period.**

## ***ASSISTANCE***

**This manual is designed to provide the necessary information for trouble-free installation and operation of your new Serial to Ethernet Protocol converter. However, if you need assistance, please call Brainchild Electronic Co. Ltd. at +886-2-27861299 Ext 613  
Or visit our web site at [www. Brainchild.com.tw](http://www.Brainchild.com.tw)**

## *MANUAL REVISION*

If you contact us in reference to this manual, please include the following document number

Name: User Manual for PCE

Document: UMPCEA, 05, 2007

Revision: 1.0

## **Warranty Certificate**

**For New product:** This product is warranted against defects in materials and workmanship for a period of 12 months from the date of shipment to Buyer. **For Rectified Products:** Any product that will be replaced will have Warranty for 6 months or up to Original Product Warranty period whichever is greater. The warranty is limited to repair or replacement of the defective unit at the option of the manufacturer. This warranty is void if the product has been altered, misused, dismantled, or otherwise abused.

**ALL OTHER WARRANTIES, EXPRESSED OR IMPLIED, ARE EXCLUDED, INCLUDING BUT NOT LIMITED TO THE IMPLIED WARRANTIES OF MERCHANTABILITY AND FITNESS FOR A PARTICULAR PURPOSE.**

## *MAINTENANCE & SERVICE*

There are no parts that can be serviced by the user. Service should be performed on a unit substitution basis only. Do not attempt to remove, replace or service any printed circuit board, components or any hardware/software related with display product. If problem within the display product occurs, contact the factory for service information or repair.

**Any Mechanical or Electrical Modification to this Unit will void All Warranties**

## *DISCLAIMER*

Information contained herein is subject to change without notice. Every precaution has been taken in the preparation of this manual. Nevertheless, Brainchild Electronics assumes no responsibility, express or implied, for errors or omissions or any damages resulting from the use of the information contained in this publication.

All trademarks belong to their respective owners

# TABLE OF CONTENTS

1.	Description .....	5
2.	Operating Modes .....	5
2.1	Mode 0.....	5
2.1.1	Modbus gateway – Using TCP .....	5
2.1.2	Transparent Mode – Using TCP .....	6
2.1.3	Modbus gateway – Using UDP .....	6
2.1.4	Transparent Mode – Using UDP .....	6
2.2	Mode 1.....	7
2.2.1	Modbus gateway – Using TCP .....	7
2.2.2	Transparent Mode – Using TCP .....	7
2.3	Mode 2.....	7
3.	Physical Dimensions.....	8
3.1	Grounding/Shielding .....	8
4.	Technical Specification .....	9
5.	Wiring.....	9
6.	Configuration.....	10
6.1	Power Connections .....	10
6.2	Ethernet Connection .....	10
6.3	Indication LED'S .....	10
6.4	Connecting to a PC which is not Connected to a Network .....	11
6.5	Connecting to a PC which is connected to a Network .....	12
6.6	Testing the Connection.....	13
6.7	Viewing Web Pages.....	14
6.8	Troubleshooting Guide .....	15
6.9	Parameter Configuration.....	16
7.	Conformity Certificate.....	19

## 1. Description

---

The Ethernet/Serial Converter enables serial devices, such as Modbus based IO modules communicating on RS232/485 to be connected to a 10/100 Base-TX Ethernet network. The Ethernet/Serial Converter can be configured to operate in a number of different modes depending on the application. It can be configured as a transparent data link or it can perform the gateway function of converting Modbus TCP messages to Modbus RTU messages.

The PC-E converters are factory programmed with a default IP address of 192.168.0.112. This address must be changed before the converter is added to an existing Ethernet network. The IP address in the converter should be unique in the network and can be changed via the Web Server. Web server allows setting IP address, serial data format and operating modes. The web server can be accessed by most web browsers like Internet explorer, Netscape etc. PC-E supports FTP protocol which enables the web pages to be customized if required.

The web page address for viewing the setup parameters is <http://192.168.0.112/index.htm> the web page address for configuring the converter is <http://192.168.0.112/ip.htm>

The master device which is polling the modules must be configured with the IP address of the converter and with the Modbus ID of the Modbus modules. As each RS485 network is separate, it is possible to have repeated Modbus ID's on the RS485 networks. The IP address differentiates between the different RS485 networks. Consequently, many hundreds of IO modules may be added to an Ethernet network.

## 2. Operating Modes

---

### 2.1 Mode 0

Mode 0 is the standard server configuration for most Ethernet/serial converter applications. This mode has been designed to service multiple sockets which enables up to 4 masters to communicate with the slaves connected to the converter.

Each socket is serviced in turn, and any message in the socket is sent out on the serial port. The converter then starts a timer waiting for a reply. When a reply is received the messages is put into the initiating socket and send out on the Ethernet network. The converter then checks the next socket. If no reply is received then the timer expires and the converter checks the next socket. This timer is configured on the ip.htm web page and is labeled "Serial Reply Timeout".

The converter can also accept messages on UDP instead of TCP. Operation is the same and does not need any special configuration.

There are a number of different configurations for this mode as follows:

#### 2.1.1 Modbus gateway – Using TCP

When used as a Modbus gateway the client must be configured to use **Port 502**. This is a reserved port number for Modbus TCP applications and informs the converter that it must implement the protocol conversion from Modbus TCP on the Ethernet network to Modbus RTU on the serial network.

### 2.1.2 Transparent Mode – Using TCP

When used in transparent mode the client must be configured to use **Port 1234**. This port number informs the converter that any data that is received in a socket must be transmitted out the serial port without any protocol conversion.

### 2.1.3 Modbus gateway – Using UDP

When used as a Modbus gateway the client must be configured to use **Port 502**. This is a reserved port number for Modbus TCP applications and informs the converter that it must implement the protocol conversion from Modbus TCP on the Ethernet network to Modbus RTU on the serial network.

### 2.1.4 Transparent Mode – Using UDP

When used in transparent mode the client must be configured to use **Port 1234**. This port number informs the converter that any data that is received in a UDP datagram must be transmitted out the serial port without any protocol conversion.

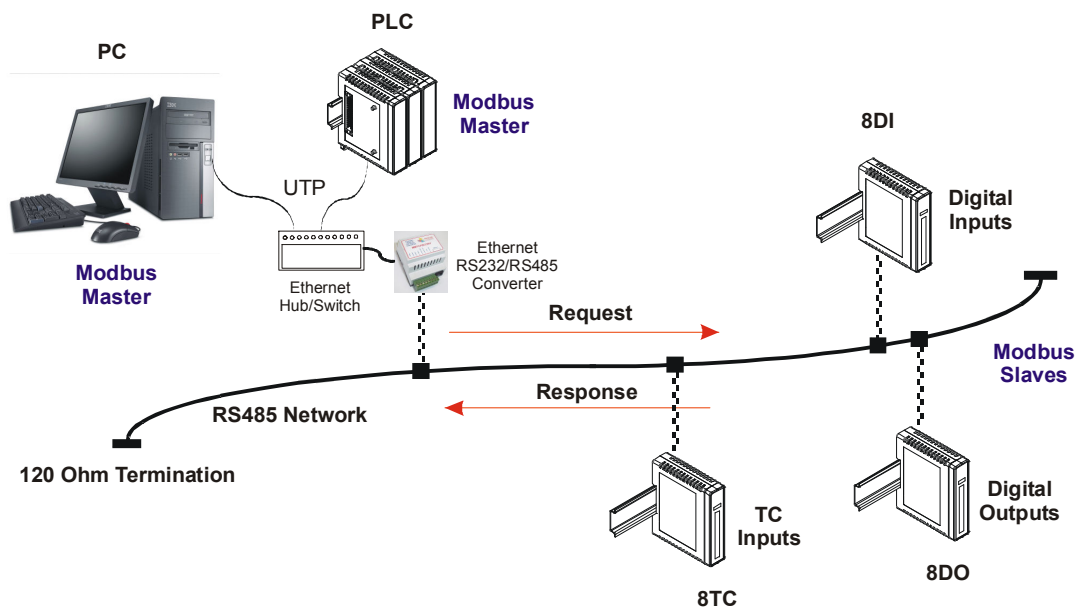

Fig: Max. 4 masters can access data of the IO modules via PC-E in Mode 0. That means Mode 0 supports multi socket communications.

## 2.2 Mode 1

Mode 1 is a server configuration and is similar to Mode 0 except that this mode only makes use of a single socket. By default, Mode 1 for simple applications.

Ex: Access IO modules data in one PC via PC-E on Ethernet.

This single socket implementation waits for messages to come in on the Ethernet network and sends them out the serial port. Any messages being received on the serial port are sent out on the Ethernet network. As there is only one socket, there is no need for the timer as in mode 0.

There are a number of different configurations for this mode as follows:

### 2.2.1 Modbus gateway – Using TCP

When used as a Modbus gateway the client must be configured to use **Port 502**. This is a reserved port number for Modbus TCP applications and informs the converter that it must implement the protocol conversion from Modbus TCP on the Ethernet network to Modbus RTU on the serial network.

### 2.2.2 Transparent Mode – Using TCP

When used in transparent mode the client must be configured to use a **PORT** number chosen by the user. This port number informs the converter that any data that is received in a socket must be transmitted out the serial port without any protocol conversion and must not be one of the reserved numbers 21(ftp), 80(http), 502(Modbus). This is the mode that is used to create a transparent **point-to-point** serial-Ethernet-serial **link** with a client converter.

## 2.3 Mode 2

Mode 2 is a Client configuration and is used to make a transparent link with a server converter. This mode only makes use of a single socket.

This single socket implementation waits for messages to come in on the Ethernet network and sends them out the serial port. Any messages being received on the serial port are sent out on the Ethernet network. As there is only one socket, there is no need for the timer as in mode 0.

When messages are received on the serial port they are sent out on the Ethernet network. Due to the fact that the Ethernet network is normally faster than the serial data being received, the serial message being received will get broken up into small blocks and then sent on the Ethernet network. This could result in the Ethernet network being flooded with many messages sending one or two characters at a time. To prevent this from happening, a timer is used. This timer starts when the first character is received on the serial port and when it expires any received characters in the serial port buffer are sent out on the Ethernet network. This timer is disabled if a value of 0 is programmed. The timer is labeled "Char **Timeout**" on the ip.htm web page.

The client converter must be configured to use a **PORT** number chosen by the user. This port number must be the same which is programmed into the server converter. This Port number informs the converter that any data that is received in a socket must be transmitted out the serial port without any protocol conversion and must not be one of the reserved numbers 21(ftp), 80(http), 502(Modbus). This is the mode that is used to create a transparent **point-to-point** serial-Ethernet-serial **link** with a server converter.

The Client converter has to open the socket with the Server converter. In order to do this, the IP address of the Server must be configured in the Client converter. This is done on the ip.htm web page and is labeled “**Server IP**”.

### 3. Physical Dimensions

---

The Converter enclosure is shown below. The module has been designed with a quick snap-in assembly for mounting onto DIN-rail's as per DIN EN 50 022.

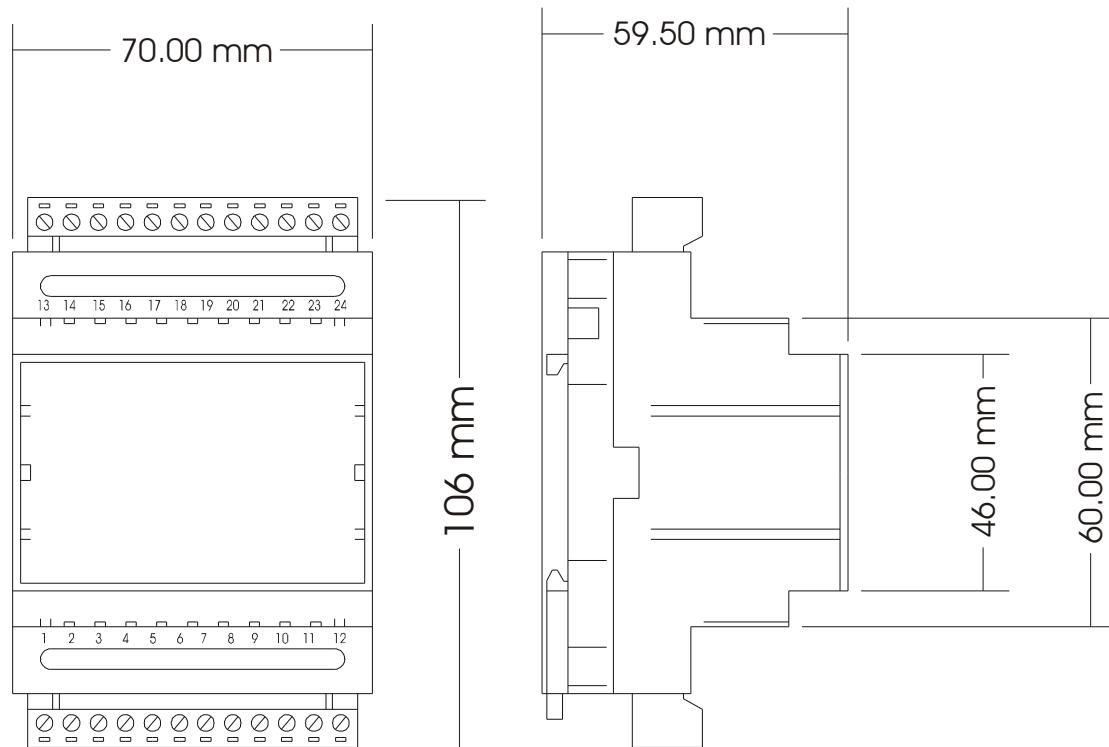

#### 3.1 Grounding/Shielding

In most cases, the converter will be installed in an enclosure along with other devices which generate electromagnetic radiation. Examples of these devices are relays and contactors, transformers, motor controllers etc. This electromagnetic radiation can induce electrical noise into both power and signal lines, as well as direct radiation into the module causing negative effects on the system. Appropriate grounding, shielding and other protective steps should be taken at the installation stage to prevent these effects. These protective steps include control cabinet grounding, module grounding, cable shield grounding, protective elements for electromagnetic switching devices, correct wiring as well as consideration of cable types and their cross sections.

1. Screened twisted pair cable must be used with the screen grounded at one point only.
2. Use should be made of screened I/O, T/C, RTD cable with the screens grounded at one point as close to the Protocol converter as possible.



## 4. Technical Specification

---

<b>Power Supply</b>	PC-E	90mA @ 10VDC / 40mA @ 26VDC
<b>Ethernet</b>	10/100 Mbps/s	10/100Base-TX
	Connector	RJ45
<b>Serial</b>	RS232	3 Wire , TX,RX,GND
	RS485	2 Wire Multi drop twisted pair
	Baud Rate	2400, 4800, 9600, 19200, 38400, 57600, 115200
	Data Bits	5, 6, 7, 8.
	Parity	None, Even, Odd.
	Stop Bits	1, 2.
<b>Temperature</b>	Operating Temperature.	-10°C to + 50°C
	Storage Temperature	-40°C to + 85°C
<b>Connectors</b>	Power and Comms.	8 way screw connector
<b>Humidity</b>		Up to 95% non-condensing.

## 5. Wiring

---

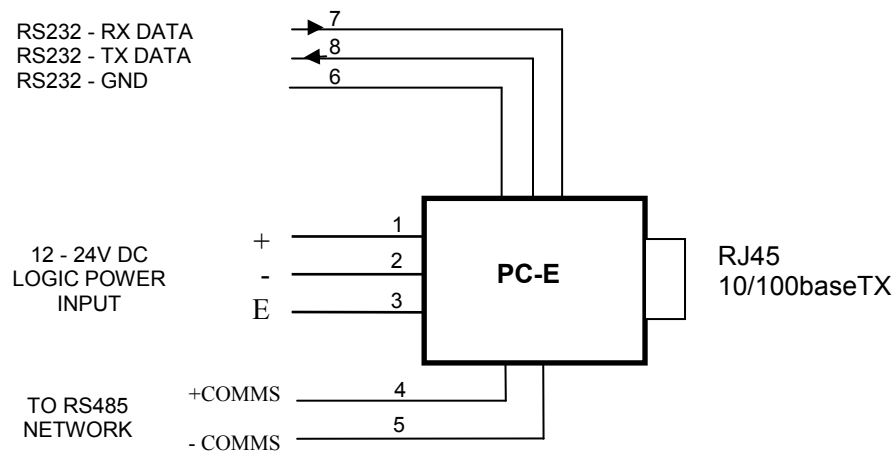

**Please Note: You must select RS232 or RS485 on the ip.htm web page**

## 6. Configuration

---

### 6.1 Power Connections

The Ethernet/Serial Protocol converter must be clipped onto a DIN rail. Power for the Protocol converter PC-E must be applied to terminal 1 (+12/24VDC) and terminal 2 (0V). The power LED will illuminate and all LED's will be off.

### 6.2 Ethernet Connection

Next the Ethernet connection is required, either through a network or directly to a PC. The Ethernet interface uses a standard RJ45 connector.

### 6.3 Indication LED'S

The led's on Protocol converter are used to indicate the operation of the module.

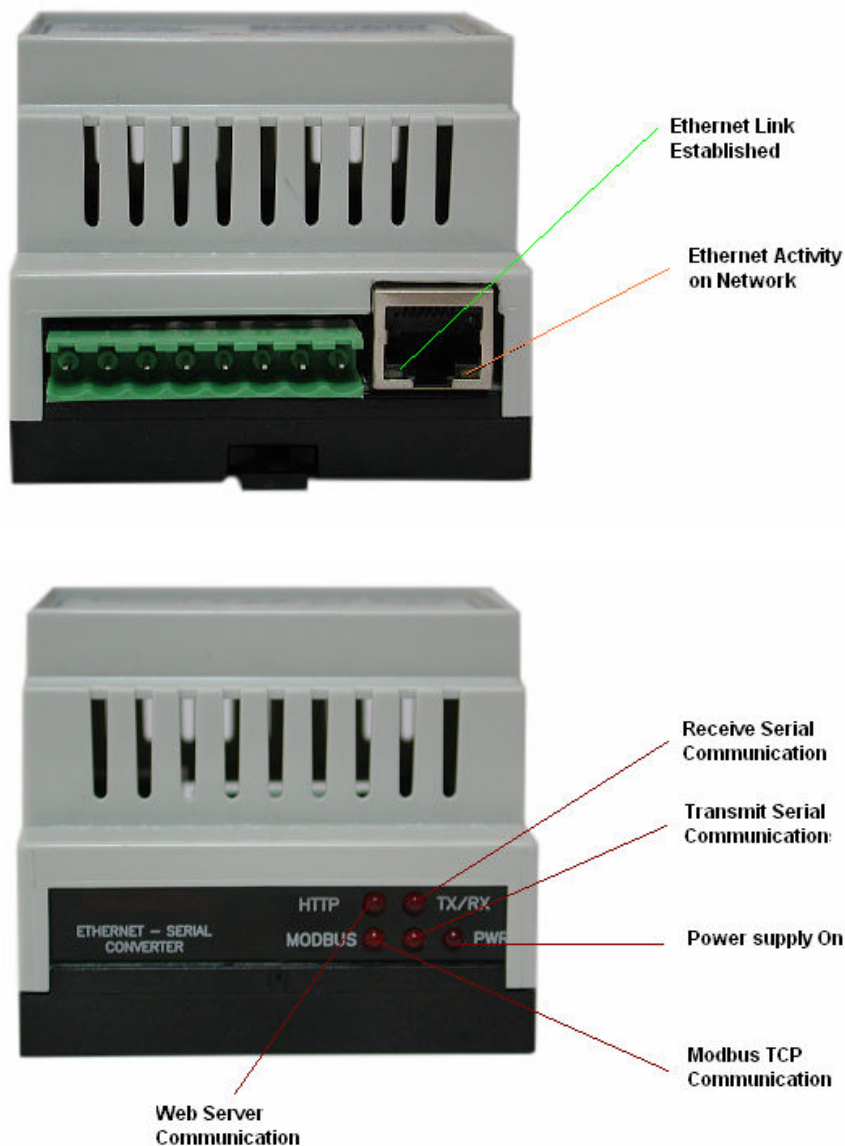

## 6.4 Connecting to a PC which is not Connected to a Network

If the PC is equipped with an Ethernet card but not connected to a network, a local network address should be used for communication between the Converter and the PC. The PC-E converter is shipped with a default IP address 192.168.0.112. For direct connection between the PC and the Protocol converter, a crossover Ethernet cable is required.

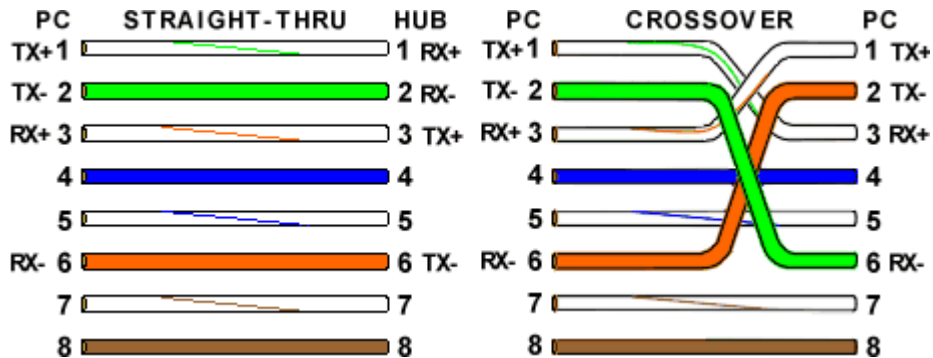

To setup your PC to connect directly to the Protocol converter PC-E, an IP address in the same range as the Protocol converter must be assigned to the PC. In Windows environments, this should be done as follows:

- Connect the PC and the Protocol converter together using a crossover cable
- Open the Windows Control Panel
- Select Network
- Select TCP/IP -> the PC's Ethernet adaptor from the Configuration tab as shown below

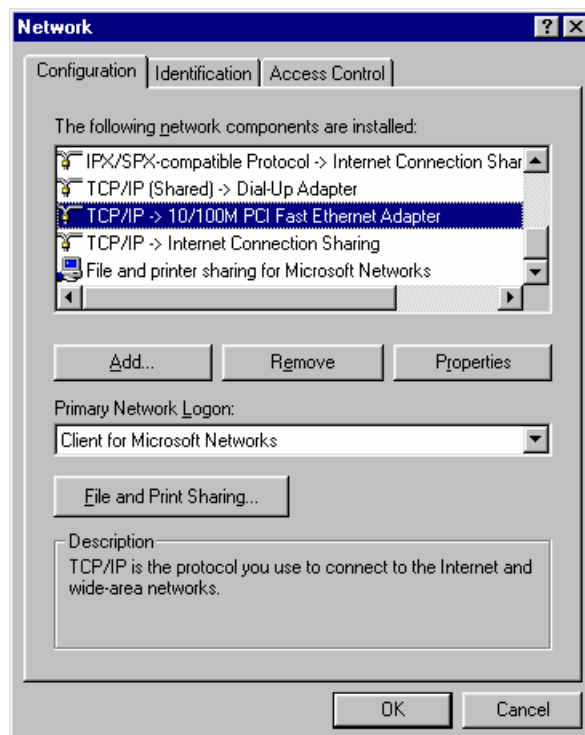

- Click the properties button. A TCP/IP Properties box similar to the one below should appear

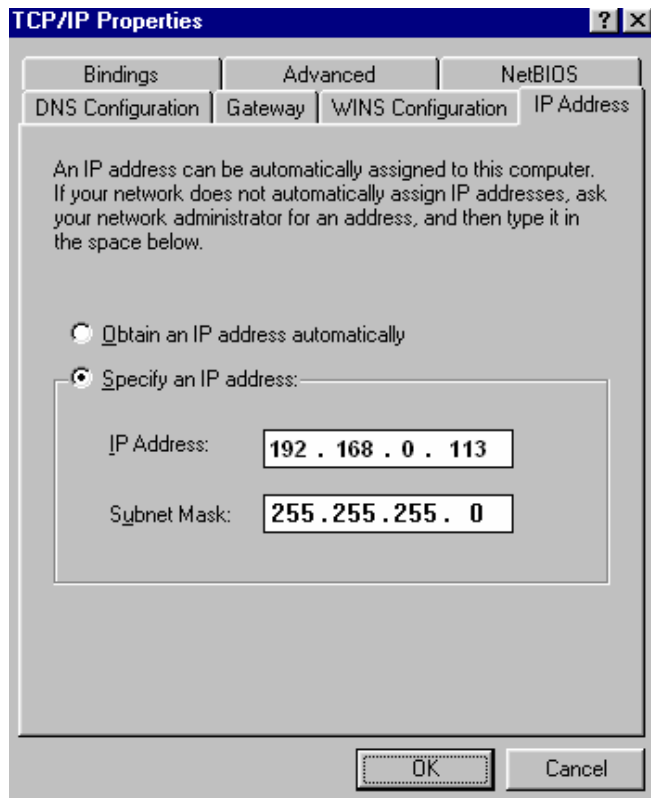

- Select the IP Address tab
- Choose to Specify an IP address as shown in the figure
- Insert the IP address 192.168.0.113 and the corresponding subnet mask as shown
- Save your settings by pressing OK in both TCP/IP properties and Network properties
- Reboot your PC

## 6.5 Connecting to a PC which is connected to a Network

If there is an Ethernet network available, the Protocol converter can be connected to any hub belonging to the network. Please note that PC-E is shipped with default IP address of 192.168.0.112. To connect PC-E with existing network first IP address of PC-E should be changed to free IP address available in the network.

1. Contact system administrator and request for free IP address in the network.
2. Remove LAN cable.
3. Change IP address to the PC as follows...

IP address: 192.168.0.113  
 Subnet mask: 255.255.255.0  
 Default Gateway: 192.168.0.1

Enable the network connection.

4. Connect cross over Ethernet cable between PC and PC-E.
5. Apply Power to PC-E
6. Observe that Ethernet link LED, (Green color) is steady on continuously. Right side LED shows link activity and you can observe slow flash.

## 6.6 Testing the Connection

To test the connection between the PC and the Protocol converter, a simple program called *ping* can be used. *Ping* sends a number of messages to the specified IP address and displays the response. The ping program can be run from the command line or from a DOS prompt on the PC, as follows:

- Open the Windows Start Menu
- Click Run
- In the Open box, type: "ping 192.168.0.112"

If the network connection is OK between PC and Protocol converter, the program will respond with:

"Reply from 192.168.0.112" and information about the response time

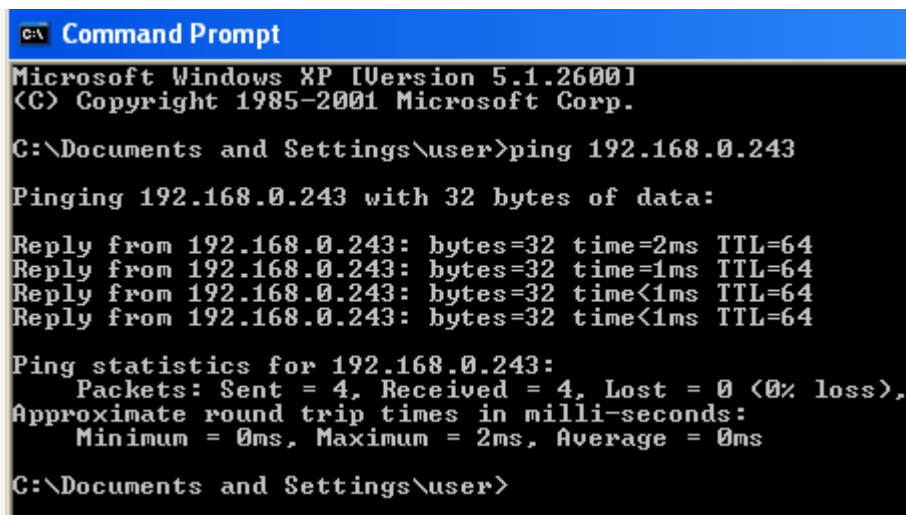

```
C:\ Command Prompt
Microsoft Windows XP [Version 5.1.2600]
(C) Copyright 1985-2001 Microsoft Corp.

C:\Documents and Settings\user>ping 192.168.0.243

Pinging 192.168.0.243 with 32 bytes of data:

Reply from 192.168.0.243: bytes=32 time=2ms TTL=64
Reply from 192.168.0.243: bytes=32 time=1ms TTL=64
Reply from 192.168.0.243: bytes=32 time<1ms TTL=64
Reply from 192.168.0.243: bytes=32 time<1ms TTL=64

Ping statistics for 192.168.0.243:
    Packets: Sent = 4, Received = 4, Lost = 0 (0% loss),
    Approximate round trip times in milli-seconds:
        Minimum = 0ms, Maximum = 2ms, Average = 0ms

C:\Documents and Settings\user>
```

If there is a problem with the network setup the program will respond as follows...

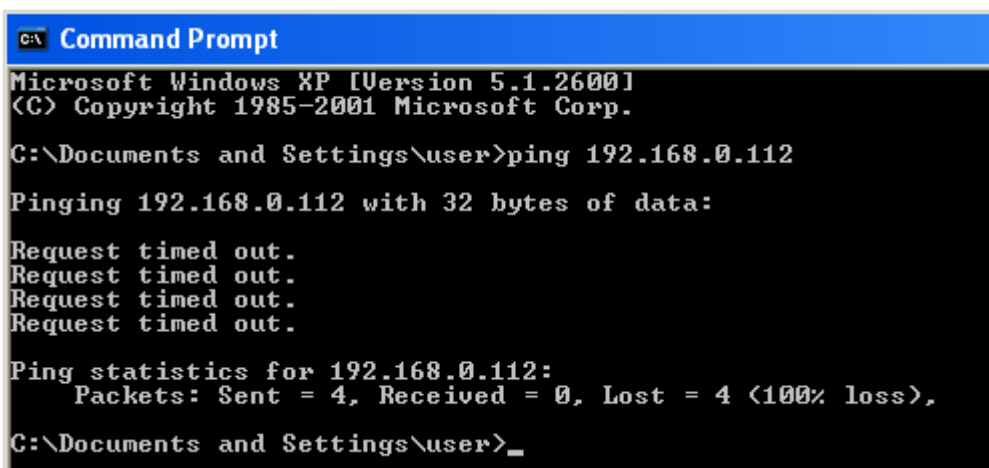

```
C:\ Command Prompt
Microsoft Windows XP [Version 5.1.2600]
(C) Copyright 1985-2001 Microsoft Corp.

C:\Documents and Settings\user>ping 192.168.0.112

Pinging 192.168.0.112 with 32 bytes of data:

Request timed out.
Request timed out.
Request timed out.
Request timed out.

Ping statistics for 192.168.0.112:
    Packets: Sent = 4, Received = 0, Lost = 4 (100% loss),

C:\Documents and Settings\user>_
```

There may be the following solutions to this problem:

- Check the Ethernet cable between PC and PC-E. We suggest that it should be cross over cable. You should not use LAN cable (straight cable) for this purpose. Check that the Link LED is illuminated when the cable is plugged into the RJ45 connector.
- Make sure that PC is set with default IP address in the range of default IP address of PC-E. Ex: You can use 192.168.0.113 for the PC.
- If you wish to use LAN cable only between PC and PC-E then make sure that your PC is set with IP address in the range of PC-E. Set PC with IP address 192.168.0.113, subnet mask: 255.255.255.0.

## 6.7 Viewing Web Pages

The Protocol converter has built in web pages. These are used for changing the configuration. To view these Web pages, a Web browser such as Internet Explorer or Netscape is needed.

To view the default Web page in Protocol converter, start the Web browser and type "192.168.0.112" into the address line of the browser window. The main page of the Protocol converter will now be displayed in the browser window.

If no Web page is displayed, go back to testing the network connection from PC to the Protocol converter by using the ping command. If the Protocol converter replies to the ping messages, check the setup of the Web browser. If the Protocol converter is directly connected to the same network as the PC, "direct connection to the network" or "bypass proxy server for local addresses" should be selected in the Web browser configuration menu. If the Protocol converter is connected to the PC through a firewall, a proxy server should be selected in the configuration menu. Contact the local network administrator for information about the network configuration.

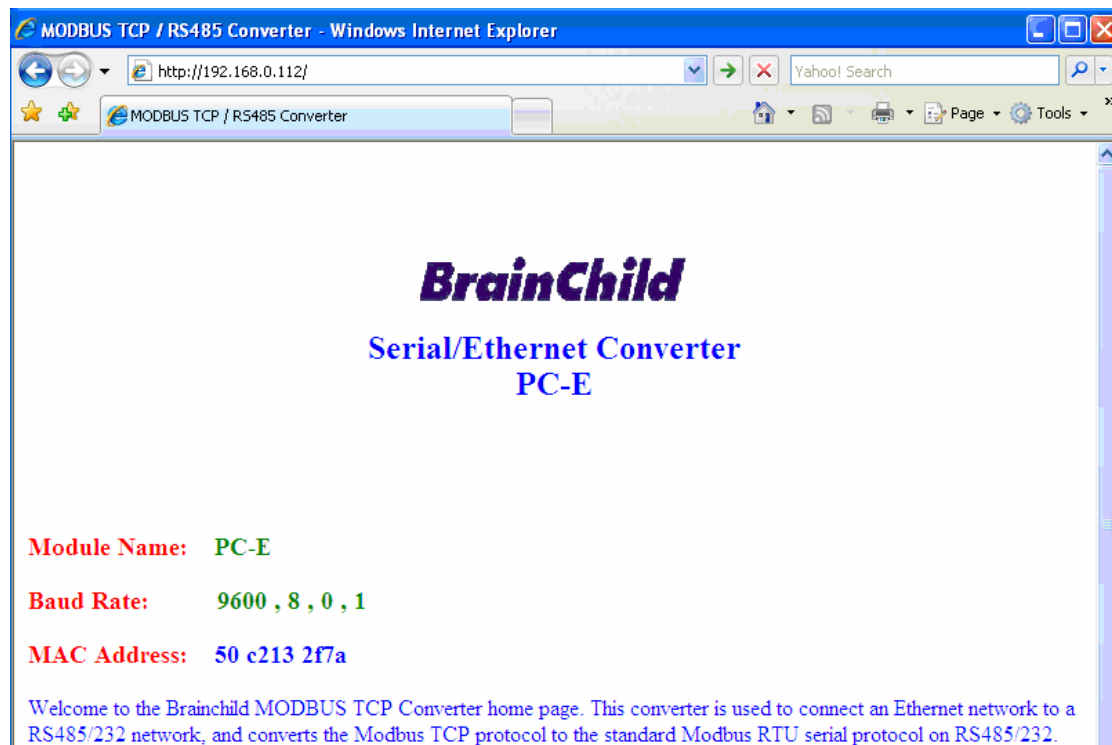

## 6.8 Troubleshooting Guide

No	Checkpoint		Solution
1	Is the LINK LED on and is the ACTIVITY LED flashing with short pulses?	No	No network connection is detected. The Ethernet cable is either not plugged in or wrong type of cable is used. For connection to a network with a hub or switch, a straight through network cable can be used. For direct connection between PC and Protocol converter, a cross over Ethernet cable must be used.
		Yes	A network connection is detected; the Protocol converter is connected to the network.
2	Does the Protocol converter respond to PING requests?	No	Either the PC or the Protocol converter is setup with wrong IP address. Set PC-E with default IP address. To change the IP address of a PC, use the Windows "control panel -> network -> TCP/IP properties" and setup an IP address close to the Protocol converter address. The Protocol converter is shipped with a default IP address of 192.168.0.112, the PC can be setup with an IP address of 192.168.0.113
		Yes	The PC and Protocol converter are setup with a correct IP address and they are able to communicate with each other.
3	Can the default Web page be accessed in a Web browser?	No	This is normally caused by the setup of the Web browser. In the "options" or "preferences" menu, check that the Web browser is configured for direct network connection or local area network and <b>NOT</b> using a proxy server.
		Yes	No problems.
4	Are the LINK LED and ACTIVITY LED flashing together?	Yes	Switch off the power to PC-E. Wait for some time before switching on the power for next time.
		No	No Problems

### Procedure to set PC-E to default IP address

- a. Remove power.
- b. Remove "Default IP" jumper.
- c. Plug in Ethernet cable and connect to switch.
- d. Apply power.
- e. After about 2 seconds the link LED should come on and must not flash. (LED closest to green connector)
- f. Replace jumper.

## 6.9 Parameter Configuration

The Web page address "192.168.0.112/ip.htm" is entered into the address line of the browser window to access the configuration page. This page allows you to change the IP address of the Protocol converter, select serial timeout, to setup the baud rate of the Protocol converter on the RS485 network, and to enter a Module Description Name for identification/maintenance purposes.

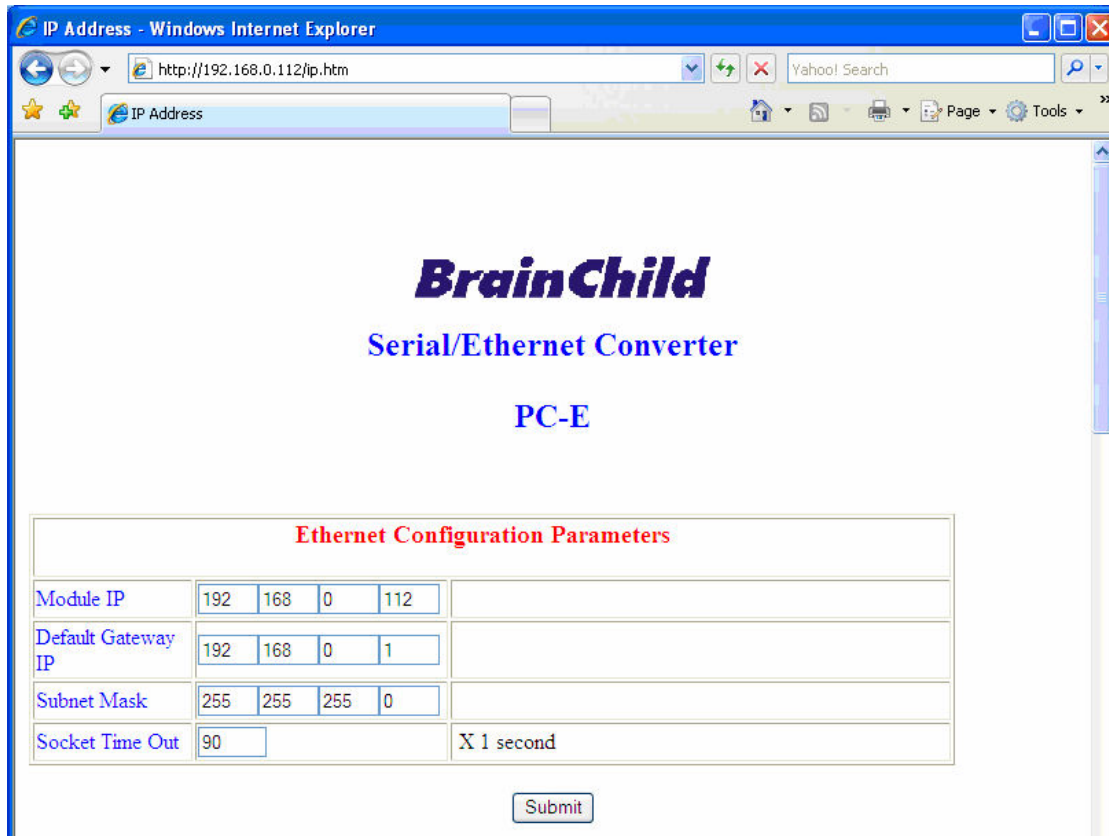

The screenshot shows a Windows Internet Explorer browser window with the address bar containing "http://192.168.0.112/ip.htm". The page content is as follows:

**BrainChild**  
**Serial/Ethernet Converter**  
**PC-E**

**Ethernet Configuration Parameters**

Module IP	192	168	0	112	
Default Gateway IP	192	168	0	1	
Subnet Mask	255	255	255	0	
Socket Time Out	90				X 1 second

- **IP Address:** The new IP address can be entered into the web page as shown above. After this has been done, you must click the Submit button to send the values to the Protocol converter. The screen will now be updated and if successful will continue to display the new IP address. The new IP address will only be effective after the Protocol converter power has been switched off and on again. This feature allows you to check that the correct IP address has been entered before being activated. If the IP address has been entered incorrectly and the power has not been switched off, it is possible to re-enter the correct IP address. Please note that if the power has been switched off and back on again, the Protocol converter will not communicate until you enter the new IP address into the address line of the browser window.
- **Default Gateway IP Address:** A **default gateway** is a node (a router) on a computer network that serves as an access point to another network. In enterprises, however, the gateway is the computer that routes the traffic from a PC to the outside network that is serving the Web pages. It is only necessary to configure the default gateway IP address if the PC that is accessing the Converter is on a different network.
- **Subnet Mask:** In computer networks, a **sub network** or **subnet** is a range of logical addresses within the address space that is assigned to an organization. The subnet



mask is used to inform the Converter that it must send its replies to the gateway if the IP address of the PC is on a different network. When the subnet mask is set to "0.0.0.0" then it is effectively disabled and the default gateway is not used. A typical subnet mask would be "255.255.255.0".

- **Socket Timeout:** If a socket connection is broken, say due to a network fault, it must timeout to free it up so that it can be used again. This timer is triggered by activity on the converter, so if there is no communications activity for longer than the timeout period, the socket will close.

Communication Modes	
Converter Mode	<input type="text" value="1"/> 0 = Server - Standard Mode / Multi Socket 1 = Server - Socket Listen Mode / Single socket 2 = Client - Remote Socket Open Mode / Single socket
Char Timeout	<input type="text" value="25"/> Time to wait before sending Rx Chars when using Port 30004 in Mode 0, or using Mode 1/2 X 10 milliseconds
Port Number	<input type="text" value="502"/> Modbus TCP = 502 Mode 1&2 only
Server IP	<input type="text" value="192"/> <input type="text" value="168"/> <input type="text" value="0"/> <input type="text" value="240"/> Mode 2 only

- **Converter Mode:** These modes have been described in detail in a section 2. Enter 0, 1 or 2 as required. For simple applications, say Data Acquisition Studio software in PC is Master and IO modules are RTU slaves, then select 1
- **Char Timeout:** This timeout has been described in detail in a section 2. Enter a value in 10millisecond increments.
- **Port Number:** The Port number used to tell the converter that the incoming TCP/UDP message must get sent to the serial port.
- **Server IP:** The client converter in mode 2 must connect to the server converter. Enter the IP address of the server converter in this field.

IP Address - Windows Internet Explorer

http://192.168.0.112/ip.htm

IP Address

### RS232/RS485 Communications Port Parameters

Baud Rate	9600	
Data Bits	8	
Parity	0	0=None, 1=Even, 2=Odd
Stop Bits	1	
RS232/RS485	1	0=RS232, 1=RS485
Serial Reply Timeout	25	X 10 milliseconds
RS485 On Delay	0	X 1 milliseconds
RS485 Off Delay	0	X 1 milliseconds

**Module Name**

- **Baud Rate, Data Bits, Parity, and Stop Bits:** The configuration of the serial port can be configured by selecting the parameters from the pull-down menu. Click on the Submit button to load these values into the Protocol converter.
- **RS232/RS485:** This field is used to select RS232 or RS485 on the serial port
- **Serial Reply Timeout:** This timeout is the time the module waits for a reply from a slave device. If a reply is received then this timeout is cancelled and the converter looks for the next TCP message. If the slave does not send a reply, then this timeout will expire and allow the converter to look for the next TCP message. This timeout must be longer than the turn-around time of the slave device or it will timeout before the slave replies. This timeout only operates in Mode 0
- **RS485 on Delay:** This is the time the RS485 transmitter will be enabled before data is transmitted. This has no effect on RS232 communications
- **RS485 off Delay:** This is the time the RS485 transmitter will be enabled after data is transmitted. This has no effect on RS232 communications
- **Module Name:** This field allows you to enter a module description name into the Protocol converter. This is an identifier for diagnostic/maintenance purposes and is chosen to best describe the Protocol converter in the system by name or number.

## 7. Conformity Certificate

<b>DECLARATION OF CONFORMITY</b> according to EN 45014		
Manufacturer's Name:	Brainchild Electronic. Co.Ltd	
Manufacturer's Address:	No.209, Chong Yong Road Nankang district Taipei, Taiwan	
declares that the product		
Product Name:	Protocol Converter, Serial to Ethernet	
Model Number(s):	PC-E	
complies with EMC Directive 89/336/EEC and Low Voltage Equipment Directive 73/23/EEC and conforms to the following Product specifications:		
Safety:	IEC 950	
EMC:	IEC 61000-4-2-A1 Level 2 IEC 61000-4-3-A1 Level 2 IEC 61000-4-4 Level 3 CISPR 11:1991-A1 / EN 55011:1998 Group 1 Class A	
Taiepi, Taiwan Location	May 2007 Date	Mr.Peter Lio Vice President