



INSTALLATION AND OPERATION MANUAL

Software version 1.4x

code 80290C / Edition 06 - 09/08 ENG

GENERAL INDEX

	Page		
	2		
1 Preliminary instructions	2	Application notes	39
General description	2	HOLD function	39
Basic version	2	FLASH function	39
Indicator / Interceptor	2	Alarms	39
Options	2	Software ON/OFF switching function	39
Operator interface	3	String assigned to an alarm	40
Electrical interface	3		
Preliminary warnings	3	5 Technical specifications	41
2 Installation and connection	4	6 Maintenance	42
Electrical power supply	4	Cleaning	42
Notes concerning electrical safety and Electromagnetic compatibility	4	Repairs	42
Advice for correct installation for EMC	5	Checking the jumpers	42
Instrument power supply	5	Troubleshooting Guide	42
Inputs and outputs connection	5	7 Technical-Commercial information	43
Dimensions and cut-out	6	Order code	43
Installation with panel mounting	6		
Warnings and instructions for mounting to the panel	6	Accessories	
Nominal ambient conditions	6	RS232/TTL interface for Gefran Instrument configuration	43
Electrical connections	7		
3 Functions	17	Appendix	44
Operator interface	17	Block Diagrams	49
General operating notes	18	Functional diagram	50
Navigating through the Indicator / Interceptor	19	Examples of custom linearization	56
4 Configuration and programming	21		



The contents of each section are summarized immediately following the section heading

Graphic symbols used

To distinguish between the type and importance of the information provided in these instructions for use, graphic symbols have been used as a reference to make interpreting the information clearer.



Indicates the contents of the various manual sections, the general warnings, notes, and other points to which the reader's attention should be drawn.



Indicates a particularly delicate situation that could affect the safety and correct working operation of the controller, or a rule that must be strictly observed to avoid dangerous situations



Indicates a condition of risk for the safety of the user, due to the presence of dangerous voltages at the points shown



Indicates a suggestion based on the experience of the GEFRAN Technical Staff, which could prove especially useful under given circumstances



Indicates a reference to Detailed Technical Documents available on the GEFRAN web site www.gefran.com

1 • PRELIMINARY INSTRUCTIONS



This section contains information and warnings of a general nature which should be read before proceeding with controller installation, configuration and use.

General Description

The instrument is appropriate for acquisition of signals with high variation speed. It has two main analog inputs for many applications, including differential measurements. The inputs are configurable from the keyboard and accept standard linear signals (and custom linearized signals), as well as signals from pressure probes, load cells, potentiometers, TC, RTD.

They offer an exclusive combination of performance, reliability, and applicative flexibility. In particular, this new line of Gefran indicators/alarm units is the ideal solution for sectors demanding high performance and continuity of service, with:

- pressure measurements and setpoints on extrusion lines and injection presses for plastics
- pressure measurements and setpoints (absolute or differential)
- position measurements and setpoints
- variable setpoints in fast processes and automations, with retransmission

The instrument also has 2 digital inputs for reset, calibration, and hold functions.

The outputs (up to 4) are relay or logic, and are configurable.

An MD8 expansion is available as an alternative to out-

puts 3 and 4 for 8 additional setpoint outputs.

An optional, high-resolution, optically isolated analog output is available for analog retransmission, process variable value, peak value, setpoint, differential value.

Indicator/Alarm unit in Basic Version

(mod. 2400-0-0-4R-0-X)

- 1 universal **input** for strain gauge, potentiometer, TC thermocouples, RTD 2/3 wires and linears in current and voltage with accuracy better than 0.1% f.s.
- 2 **auxiliary inputs** for linears in current and voltage, potentiometers
- 1 **power supply** for transmitters
- 2 **digital inputs** configurable NPN or PNP
- 1 **probe power supply** selectable for strain gauge, potentiometers and transmitters
- 4 **outputs**: OUT1, OUT2, OUT3, OUT4 relay

Options

- **second universal input** (useful for differential measurements)
- 1 **analog retransmission** output
- 1 RS485 optically isolate **serial interface**
- **MD8 expansion interface** as alternate to outputs 3 and 4.

Operator Interface

All the operator interface devices are concentrated on the controller faceplate with IP54 level protection.

- 6 buttons to be used for regulation / manual selection
- 1 red/green five-digit displays
- 1 red two-digit displays
(Index for configuration parameters)
- 10 red LEDs to indicated setpoint state
- 4 red/green led for configurable indication

Electrical Interface

All connection terminals (power supply, inputs, outputs, options) are grouped together on the back of the instrument.

For technical specifications and performance details refer to Section 5 "Technical Specifications".

Preliminary Warnings



The following preliminary warnings should be read before installing and using the series 2400 indicator/interceptor. This will allow the controller to be put into service more quickly and will avoid certain problems which may mistakenly be interpreted as malfunctions or limitations of the controller.

- Immediately after unpacking the instrument, make a note of the order code and the other identification data given on the label affixed to the outside of the container and copy them to the table below. These details must always be kept close at hand and referred to the personnel involved in the event of help from Gefran Customer Service Assistance.
- Check also that the instrument is complete and has not been damaged at all during transit, and that the package contains not only the controller and these Instructions for Use, but also the two brackets for fixing to the panel and the dust protection seal - see:

SN:	(Serial n°)
CODE:	(Finished product code)
TYPE:	(Order Code)
SUPPLY:	(Type of electrical power supply)
VERS:	(Software version)

Installation with Panel Fixing in Section 2.

Any inconsistencies, omissions or evident signs of damage should be reported immediately to your Gefran sales agent.

- Check that the order code corresponds with the configuration requested for the application the instrument is needed for, referring to Section 7: "Technical - Commercial Information".
 - No. and Type of Inputs/Outputs available
 - Presence of the necessary options and accessories
 - Mains voltage supply

Example: 2400 – 0 – 0 – 4R – 2 – 1

Model 2400

Single main input

None retransmission output

4 relay outputs

Digital Communication: RS485

Power supply 100...240Vac/dc

- Before installing the instrument serie 2400 on the control panel of the machine or host system, refer to the paragraph "Dimensions and Cut-out" in Section 2 "Installation and Connection".
- Where configuration by PC is provided for, make sure the interface RS232 cable is available and the CD-ROM containing the WINSTRUM software. For the order code refer to Section 7 "Technical - Commercial Information".



Users and/or system integrators who wish to know more about the concepts of serial communication between standard PC and/or Gefran Industrial PC and Gefran Programmable Instruments, can access the various technical reference Documents in Adobe Acrobat format available in the Download section of the Gefran Web Site www.gefran.com including:

- Serial Communication
- MODBus Protocol

In the same Download section of the Gefran Web Site www.gefran.com the instrument serie 2400 reference manual is available in Adobe Acrobat format, containing a detailed description of all the adjustable parameters and procedures.

In the event of presumed instrument malfunction, before contacting Gefran Technical Service Assistance, refer to the Troubleshooting Guide given in Section 6 "Maintenance", and if necessary refer to the F.A.Q. Section (Frequently Asked Questions) on the Gefran Web Site www.gefran.com

2 • INSTALLATION AND CONNECTION



This section contains the instructions necessary for correct installation of the instrument 2400 into the machine control panel or the host system and for correct connection of the controller power supply, inputs, outputs and interfaces.



Before proceeding with installation read the following warnings carefully!

Remember that lack of observation of these warnings could lead to problems of electrical safety and electromagnetic compatibility, as well as invalidating the warranty.

Electrical power supply

- the instrument is NOT equipped with an On/Off switch: the user must provide a two-phase disconnecting switch that conforms to the required safety standards (CE marking), to cut off the power supply upstream of the instrument.
The switch must be located in the immediate vicinity of the instrument and must be within easy reach of the operator.
One switch may control more than one controller.
- if the instrument is connected to NOT isolated electrical equipment (e.g. thermocouples), the earth connection must be made with a specific conductor to prevent the connection itself from coming directly through the machine structure.

- if the instrument is used in applications with risk of damage to persons, machinery or materials, it is essential to connect it up to auxiliary alarm equipment. It is advisable to make sure that alarm signals are also triggered during normal operation. The instrument must NOT be installed in flammable or explosive environments; it may be connected to equipment operating in such atmospheres only by means of appropriate and adequate types of interface, conforming to the applicable safety standards.

Notes Concerning Electrical Safety and Electromagnetic Compatibility:

CE MARKING: EMC Conformity (electromagnetic compatibility)

in accordance with EEC Directive 89/336/CEE and following modifications.

The instrument series 2400 are mainly designed to operate in industrial environments, installed on the switchboards or control panels of productive process machines or plants.

As regards electromagnetic compatibility, the strictest generic standards have been adopted, as indicated in the table below.

BT Conformity (low voltage) in accordance with Directive 2006/95/CE.

EMC conformity has been tested with the following connections.

Function	Cable type	Length
Power supply cable	1mm ²	1m
Relay output cables	1mm ²	3,5m
Serial connection wire	0,35mm ²	3,5m
Thermocouple input	0,8mm ² compensated	5m
Strain gauge input, potentiometers, linears, "PT100" temperature resistance	1mm ²	3m
Control and retransmission analog outputs	1mm ²	3,5m
Digital Inputs / Outputs	1mm ²	3,5m

EMC EMISSION		
Generic standards, emission standard for residential commercial and light industrial environments	EN 61000-6-3	
Generic standards emission standard for industrial environment	EN 61000-6-4	
Emission AC mains	EN 61000-6-3	Classe B
Radiated emission	EN 61000-6-4	Classe A
	CISPR-16-1-4 CISPR-16-2-3 CEI R210-010	
EMC IMMUNITY		
Generic standards, immunity standard of industrial environments	EN 61000-6-2	
Electrostatic discharge immunity	EN 61000-4-2	± 4 kV contact discharge ± 8 kV air discharge
Radiated radio frequency electromagnetic field immunity test	EN 61000-4-3 +A1	10 V/m amplitude modulated 80 MHz-1 GHz 10 V/m amplitude modulated 1.4 GHz-2 GHz
Conducted disturbances immunity	EN 61000-4-6	10 V/m amplitude modulated 0.15 MHz-80 MHz
Electrical fast transient/burst immunity test	EN 61000-4-4	± 2 kV power line ± 2 kV signal line
Surge immunity test	EN 61000-4-5	Power line-line ± 1 kV Power line-earth ± 2 kV Signal line-earth ± 1 kV
Power frequency magnetic field immunity test	EN 61000-4-8	100 A/m
Voltage dips, short interruptions and voltage immunity tests	EN 61000-4-11	100%U, 70%U, 40%U,
LOW VOLTAGE DIRECTIVE SAFETY		
Safety requirements for electrical equipment for measurement, control and laboratory use	EN 61010-1	



Advice for Correct Installation for EMC

Instrument power supply

- The power supply to the electronic equipment on the switchboards must always come directly from an isolation device with a fuse for the instrument part.
- The electronic instruments and electromechanical power devices such as relays, contactors, solenoid valves, etc., must always be powered by separate lines.
- When the electronic instrument power supply is strongly disturbed by the commutation of transistor or power units or motors, an isolation transformer should be used for the controllers only, earthing the screen.
- It is essential that the plant has a good earth connection:
 - the voltage between neutral and earth must not be >1V
 - the Ohmic resistance must be < 6Ω;
- If the mains voltage fluctuates strongly, use a voltage stabilizer.
- In the proximity of high frequency generators or arc welders, use adequate mains filters.
- The power supply lines must be separate from the instrument input and output ones.

Inputs and outputs connection

- The externally connected circuits must be doubly isolated.
- To connect the analogue inputs and analog outputs the following is necessary:
 - physically separate the input cables from those of the power supply, the outputs and the power connections.
 - use woven and screened cables, with the screen earthed in one point only.
- To connect the relay outputs (contactors, solenoid valves, motors, fans, etc.), fit RC groups (resistance and condensers in series) in parallel to the inductive loads that operate in Alternating Current.

(Note: all the condensers must conform to VDE (class X2) standards and withstand a voltage of at least 220V AC. The resistances must be at least 2W).
- Fit a 1N4007 diode in parallel with the coil of the inductive loads that operate in Direct Current.



GEFRAN S.p.A. declines all responsibility for any damage to persons or property caused by tampering, neglect, improper use or any use which does not conform to the characteristics of the controller and to the indications given in these Instructions for Use.

Dimensions and cut-out

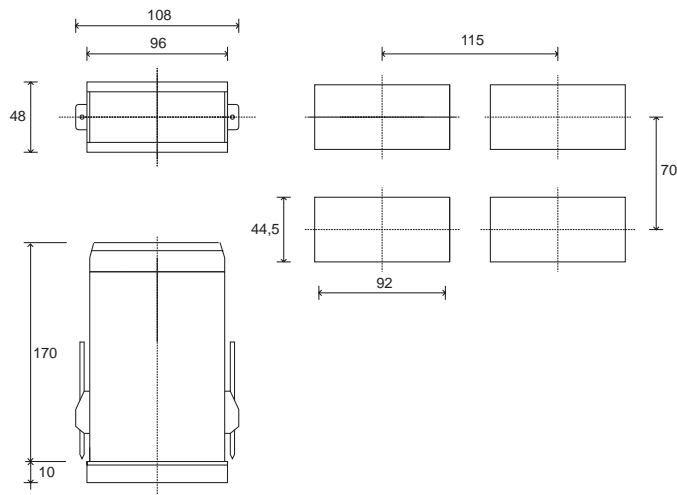

Installation with panel mounting

As well as the actual instrument and these instructions for use, the controller package also contains:

- 2 panel fixing brackets (A)
- 1 protective seal against dust and water spray (B)

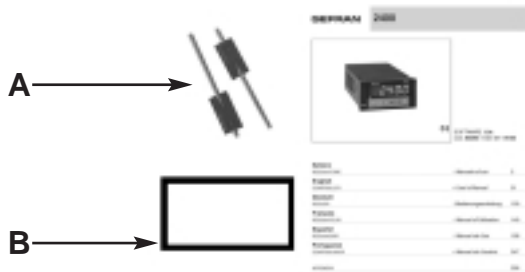

Fit the instrument to the panel as shown in the figure.

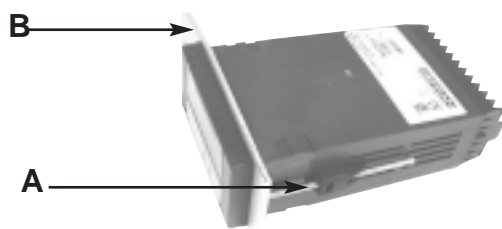

Warnings and instructions for mounting to the panel



Instructions for installation category II, pollution level 2, double isolation.

- only for models with 20...27Vac/dc power supply: supply from Class 2 or low voltage limited energy source
- the power supply lines must be separate from the controller input and output ones
- group the instruments together keeping them separate from the powered part of the relay
- do not install high-power remote switches, contactors, relays, thyristor power units (especially the "phase angle" type), motors, etc. in the same switchboard
- avoid dust, humidity, corrosive gasses and heat sources
- do not block the ventilation holes: the working temperature must be between 0...50°C
- surrounding air: 50°C
- use 60/75°C copper (Cu) conductor only, wire size range 2x N. 22 - 14AWG, Solid/Stranded
- use terminal tightening torque 0.5Nm

Nominal ambient conditions

Altitude	Up to 2000m
Working/storage temperature	0..50°C/-20...70°C
Non condensing relative humidity	20...85%



Before supplying the Indicator with power, make sure that the mains voltage is the same as that shown in the last number of the order code.

Example:

2400 - x - x - x - x - 1 = 100..240Vac/dc

2400 - x - x - x - x - 0 = 20..27Vac/dc

Electrical Connections (Mod. 2400 - 0 - x - x - x - x)

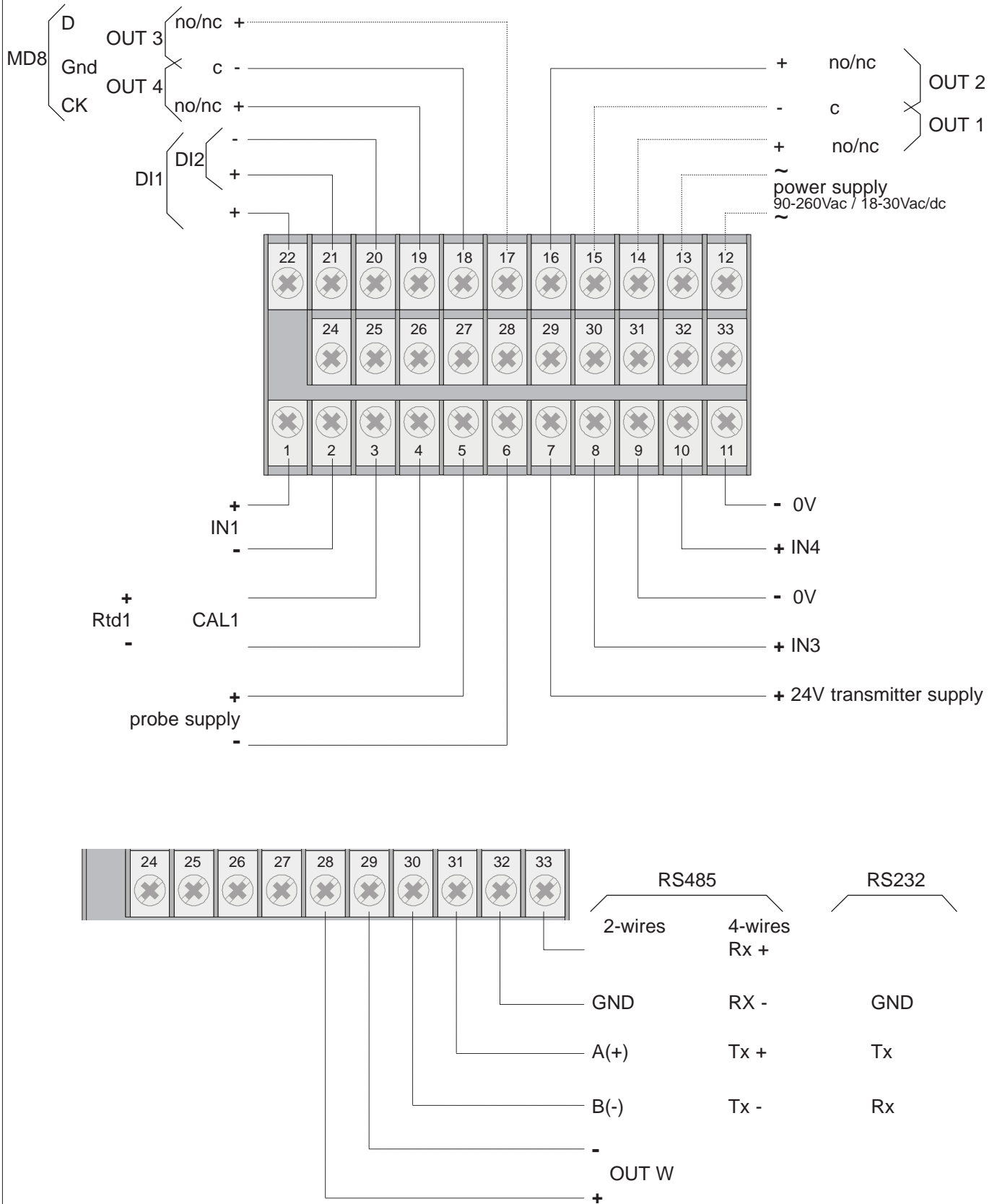

When making connections, always use wire appropriate to the voltage and current limits indicated in Section 5 – Technical Characteristics.



If the instrument has faston contacts, they must be protected and isolated.

If it has screw contacts, the wires must be attached at least in pairs

Input IN1 TC - Thermocouple

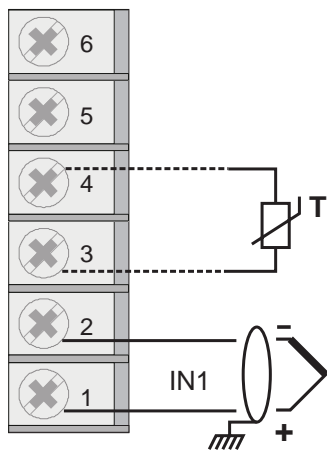

PT100 for possible compensation of external cold junction

Available thermocouples:

- J, K, R, S, T
- (B, E, N, L, U, G, D, C possible by inserting custom linearization)
- Respect polarity
- For extensions, use compensated wire suitable to the CT utilized

IN1 linear input with three-wire transmitter powered by instrument

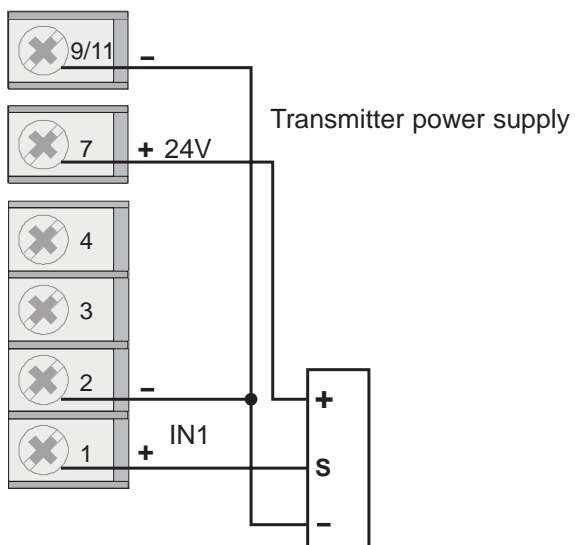

Select the probe according to transmitter type

IN1 linear input with two-wire transmitter powered by instrument

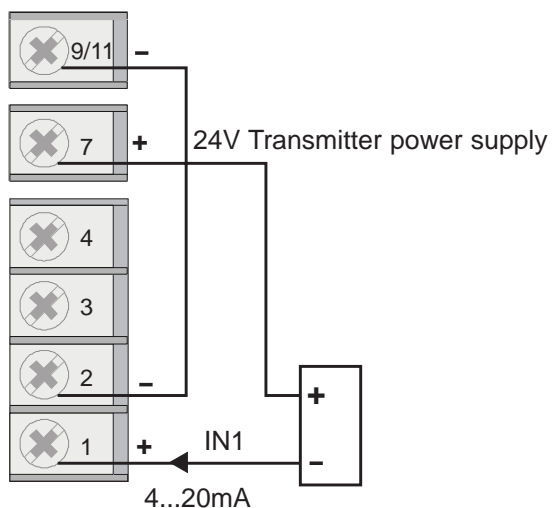

IN1 Linear input (I)

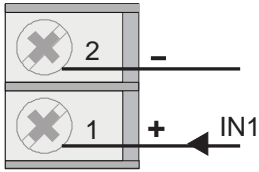

Linear input in DC
0/4...20mA, $R_i = 50\Omega$

IN1 Linear input (V)

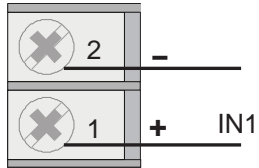

Linear input in DC
 $\pm 60\text{mV}$ $R_i > 10\text{M}\Omega$
 $\pm 100\text{mV}$ $R_i > 10\text{M}\Omega$
 $\pm 1\text{V}$ $R_i > 2\text{M}\Omega$
 $\pm 5\text{V}$ $R_i > 2\text{M}\Omega$
 $\pm 10\text{V}$ $R_i > 2\text{M}\Omega$

IN1 potentiometer input

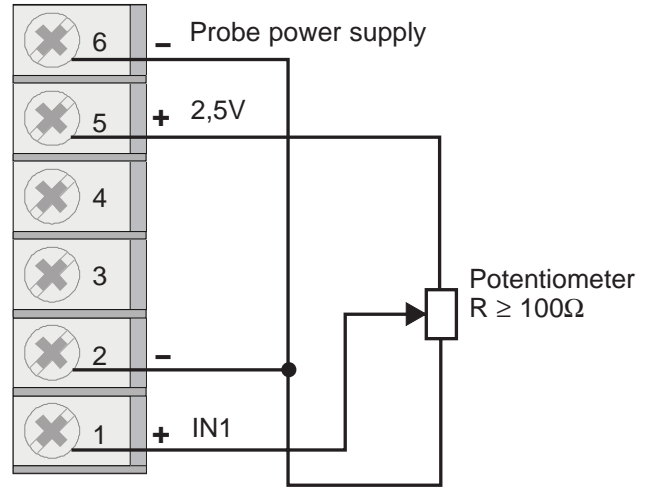

IN1 PT100 input

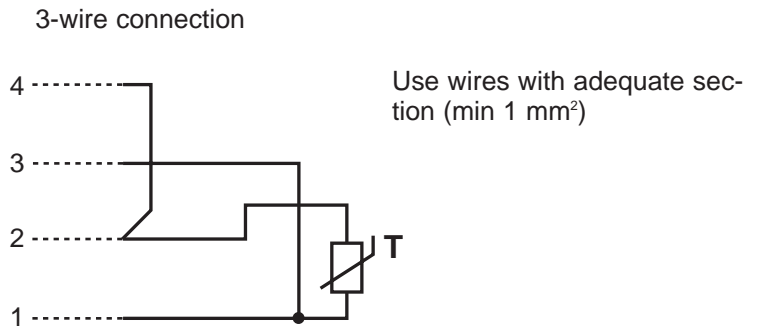
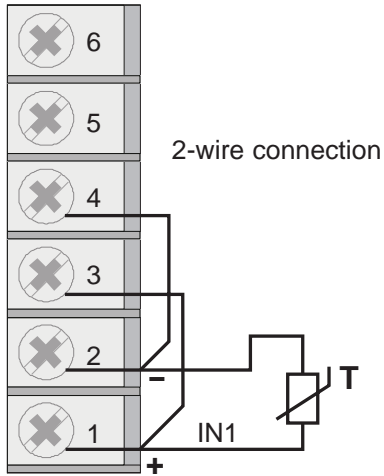

IN1 Strain-gauge input 4/6 wires

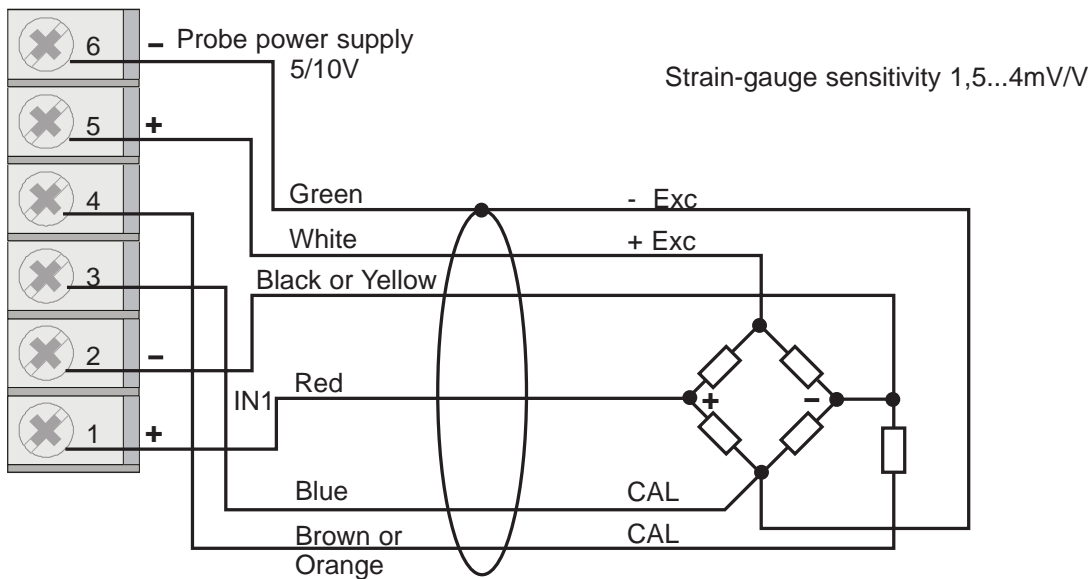

Electrical Connections (Mod. 2400 - 1 - x - x - x - x)

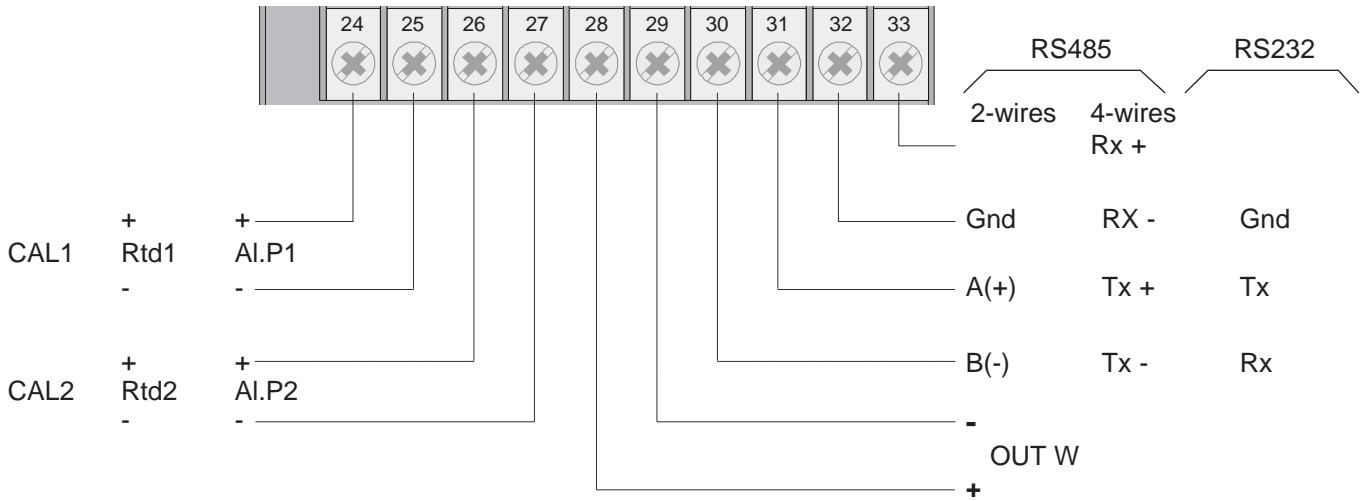
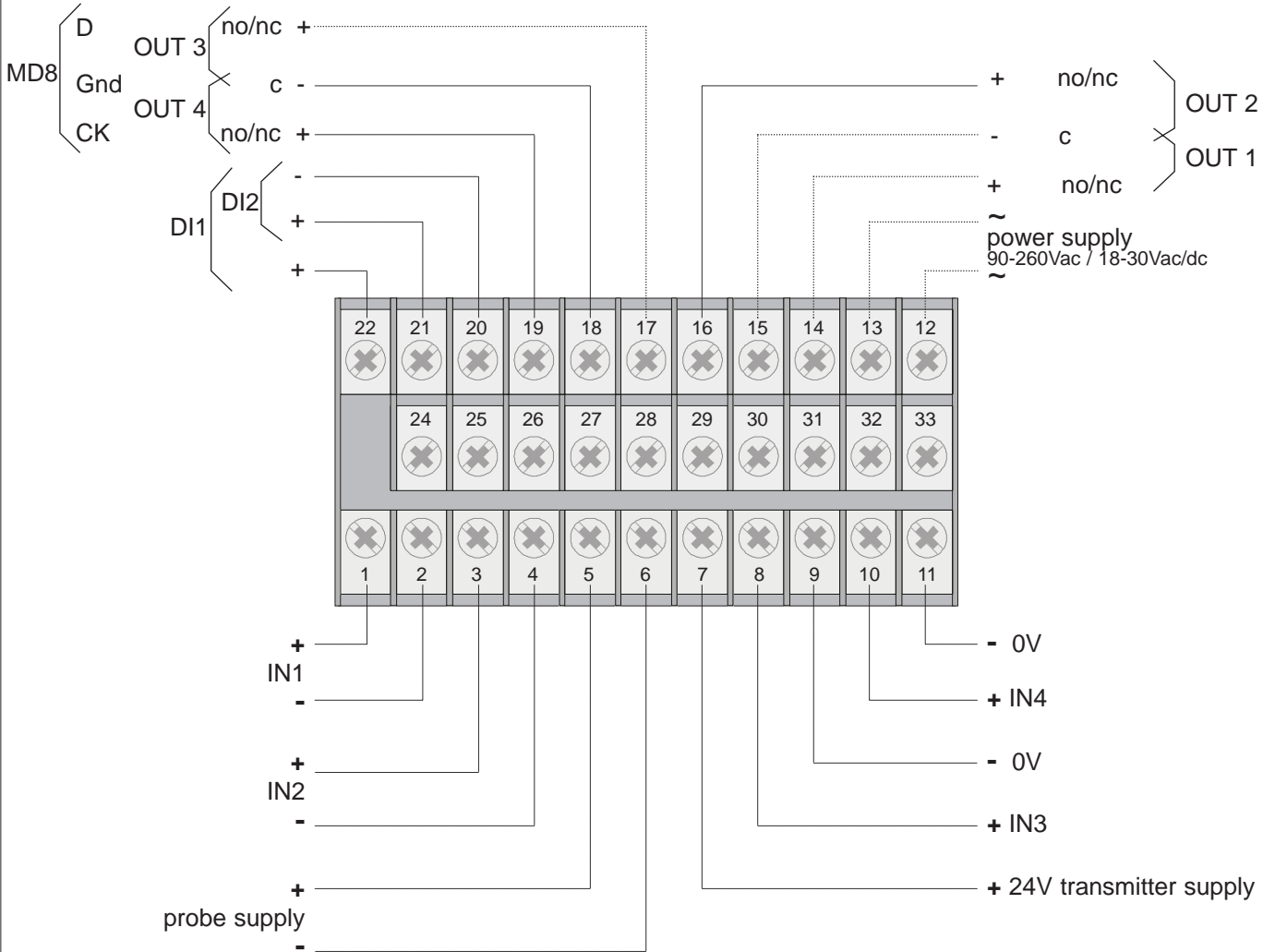

IN2 TC - Thermocouple input

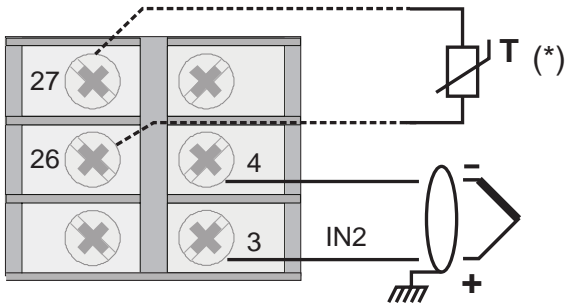

(*) PT100 for possible compensation of remote cold junction

IN1 TC - Thermocouple input

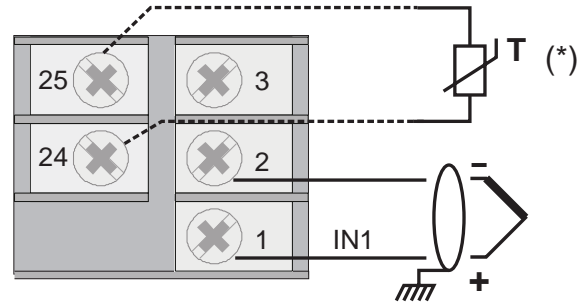

Available thermocouples:

J, K, R, S, T

(B, E, N, L, U, G, D, C possible by inserting custom linearization)

- Respect polarity

- For extensions, use compensated wire suitable to the TC utilized

IN2 linear input with three-wire transmitter powered by instrument

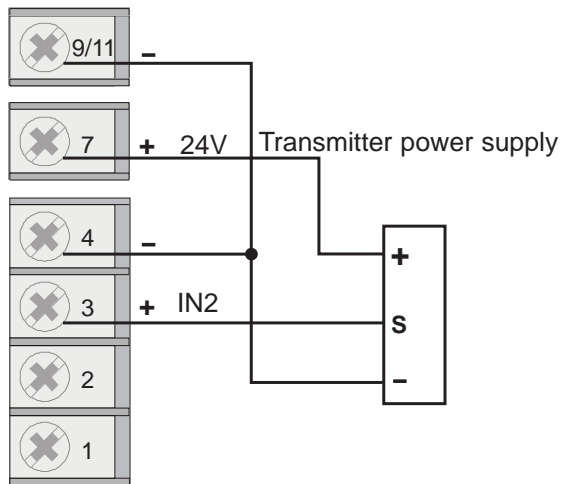

Select the probe according to transmitter type

IN1 linear input with three-wire transmitter powered by instrument

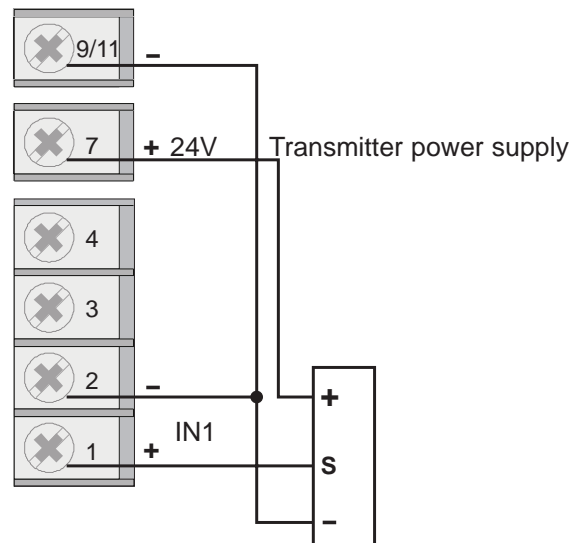

IN2 linear input with two-wire transmitter powered by instrument

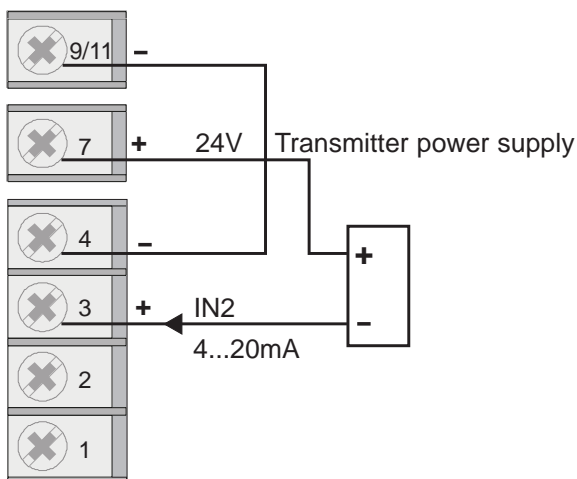

IN1 linear input with two-wire transmitter powered by instrument

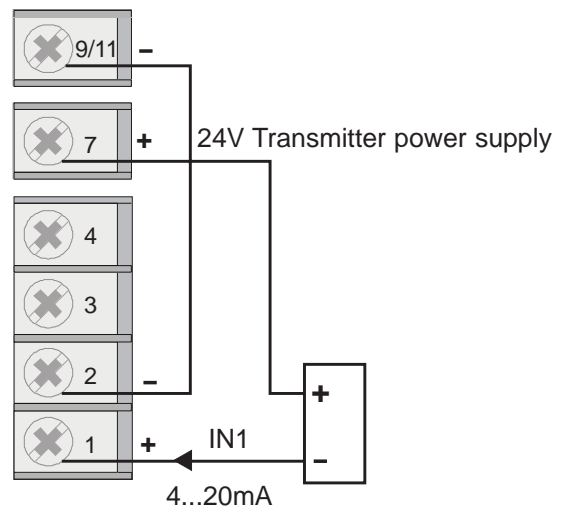

IN2 linear input (I)

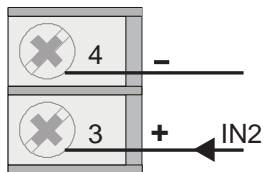

IN1 linear input (I)

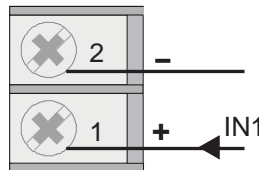

IN2 linear input (V)

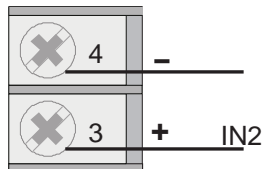

IN1 linear input (V)

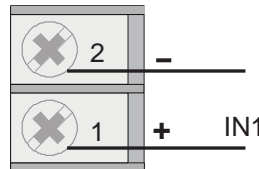

IN2 PT100 input

2-wire connection

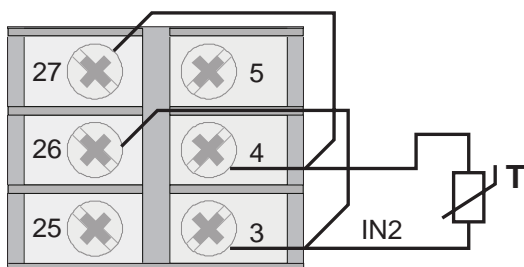

3-wire connection

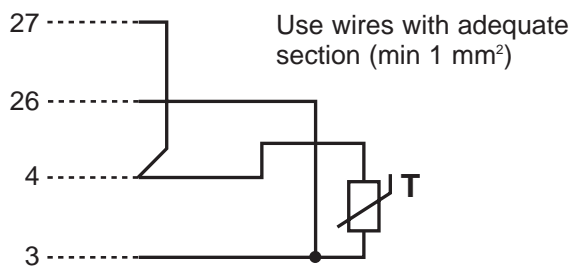

IN1 PT100 input

2-wire connection

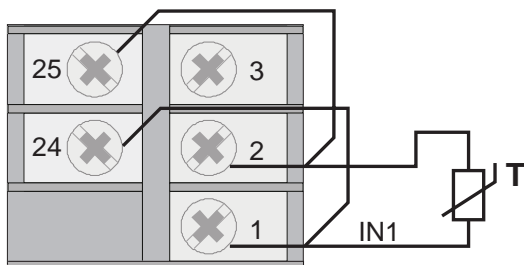

3-wire connection

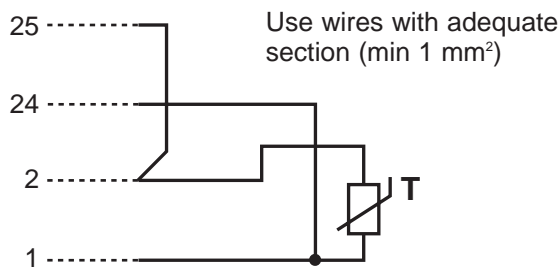

IN2 potentiometer input

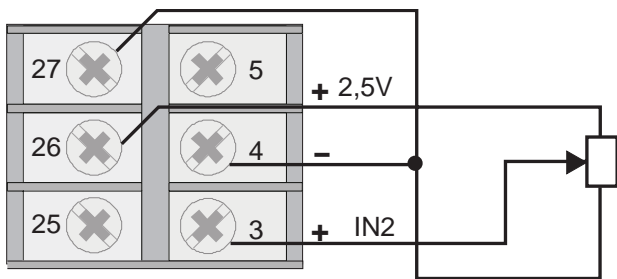

Potentiometer $R \geq 100\Omega$
Power supply 2,5V

IN1 potentiometer input

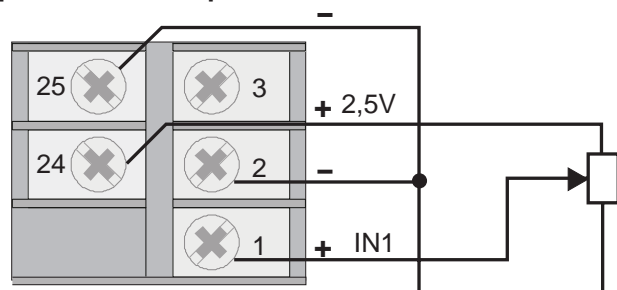

Potentiometer $R \geq 100\Omega$
Power supply 2,5V

IN2 Strain-gauge input 4/6 wires

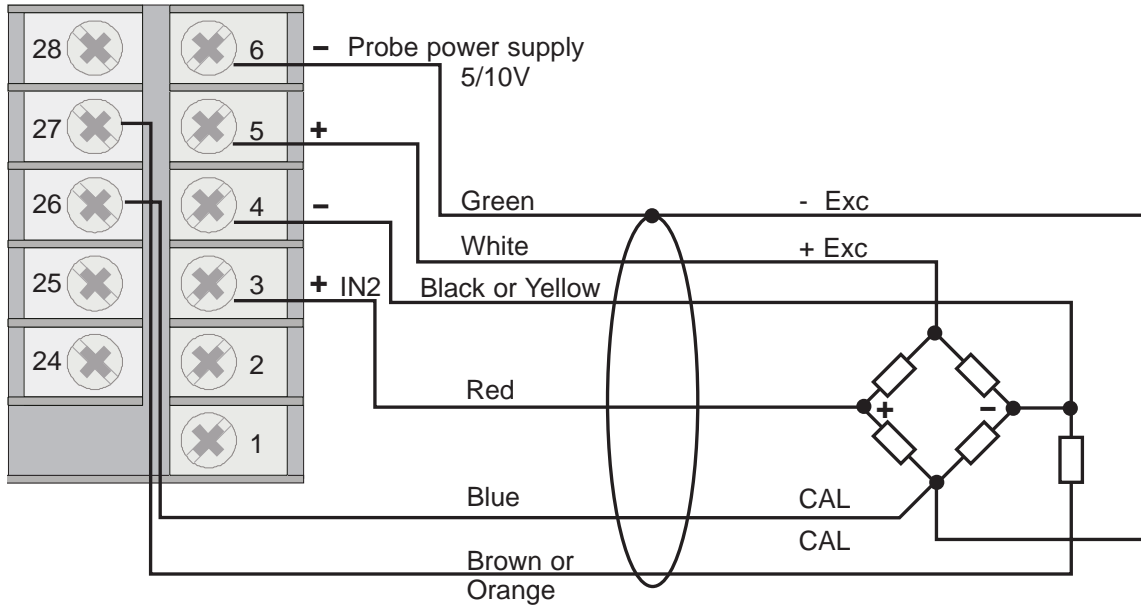

IN1 Strain-gauge input 4/6 wires

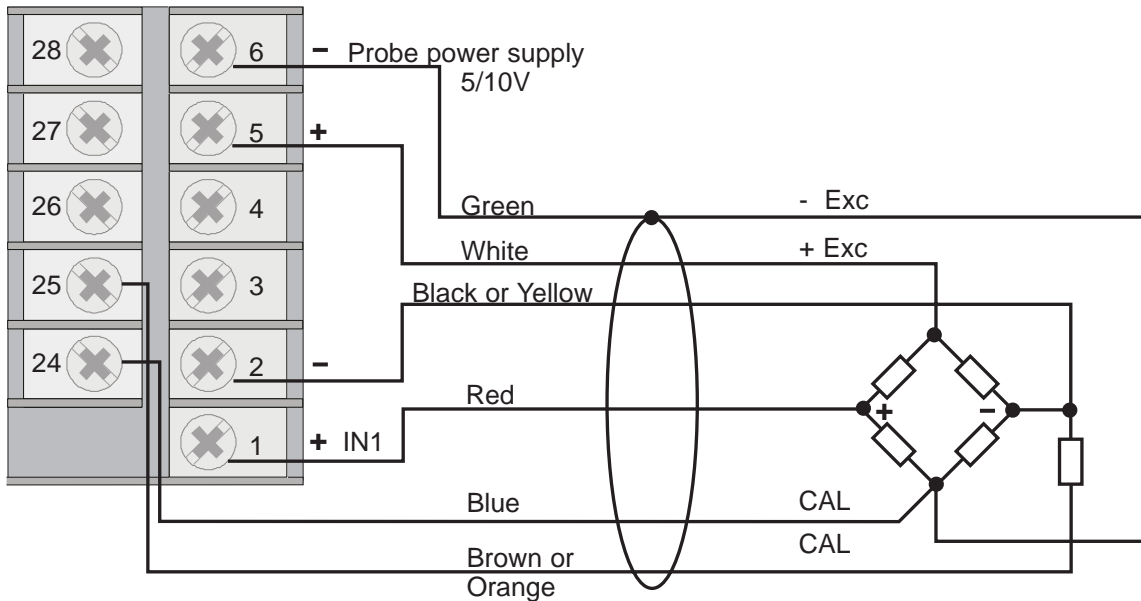

N.B.: Respect the probe connections and FASTON "CAL" connections (PROBE imbalance 80%). FASTON 24 (26) must be connected to the probe at common pin "- EXC". Reversal of the "CAL" 80% imbalance leads is indicated at the end of calibration with error signal "Hi" or "Sbr".

Electrical Connections (for all models)

IN3, IN4 linear inputs with 3-wire transmitter powered by instrument

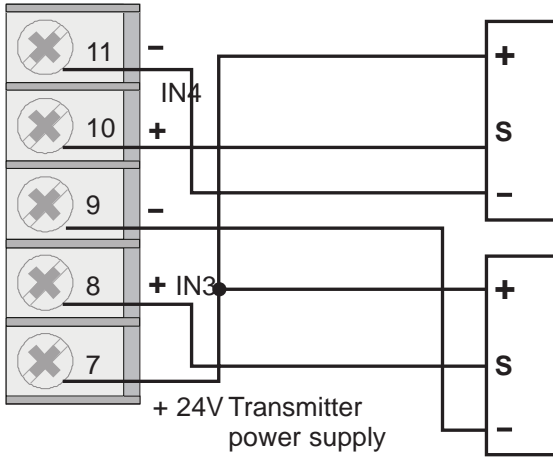

IN3, IN4 linear inputs with 2-wire transmitter powered by instrument

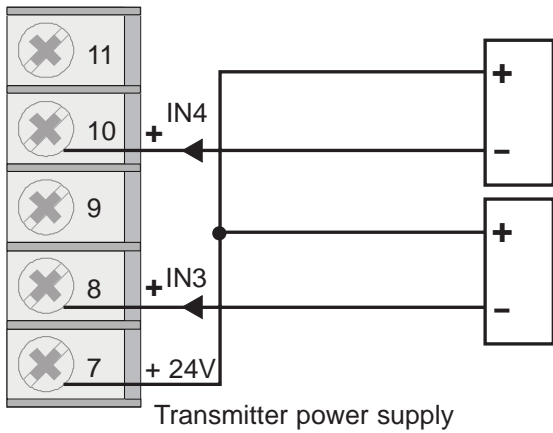

IN3, IN4 linear inputs (I)

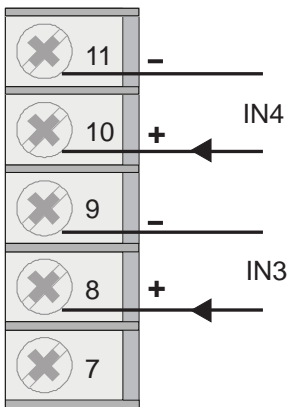

IN3, IN4 potentiometer inputs

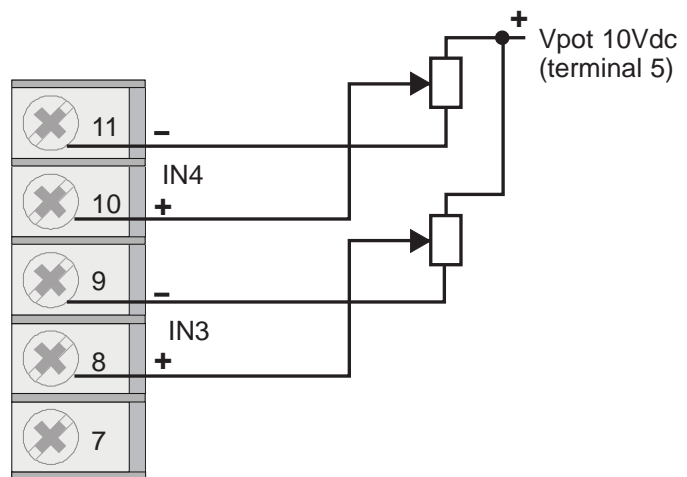

Vpot is the potentiometer power supply voltage.
The 10Vdc probe power supply can be used if available.

IN3, IN4 linear inputs (V)

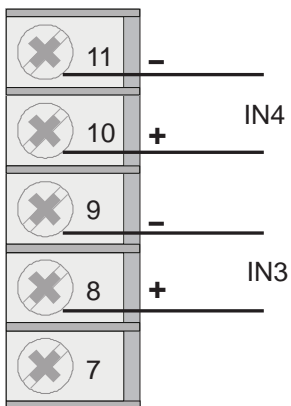

Electrical Connections (for all models)

Digital inputs DI1, DI2

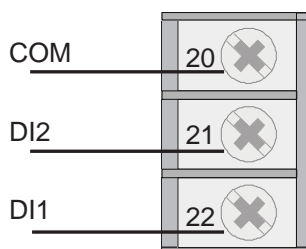

Digital inputs (PNP), 24V, max. 5mA or voltage-free contact (NPN) max. 5mA

Single selection PNP/NPN for DI1, DI2 by setting configuration parameter (Hd1 = +8)

OUT 1, OUT 2, OUT 3, OUT 4 outputs

Relay 5A, 250Vac/30Vdc

Select the no/nc contacts via jumper on power supply board (standard contact no)

(see section 6 - maintenance)

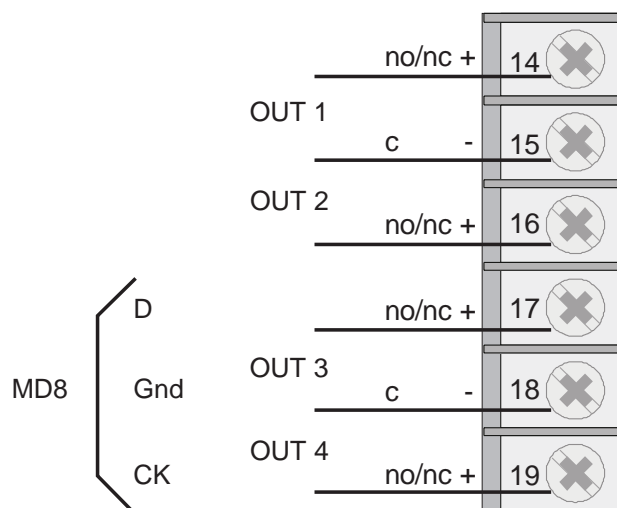

Logic 24V/30mA max

Connection with logic output

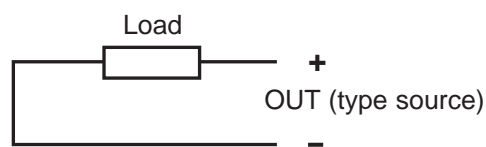
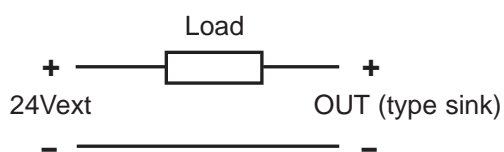

The MD8 expansion interface (D, Gnd, CK) is an alternate to outputs OUT 3, OUT 4

Electrical Connections (for all models)

Retransmission output

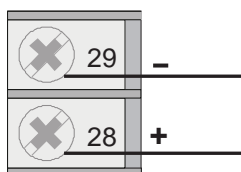

0/2...10V, $\pm 10V$, max. 25mA protection against short circuit
0/4...20mA, on load max. 500 Ω

Select type by means of configuration parameter.

Serial line - MODBUS

RS485 2-wires (standard)

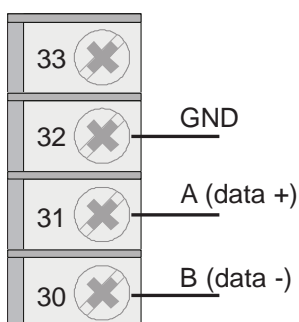

Termination strength 120 Ω line can be inserted via jumper S3 closed, S2 open
Polarization can be inserted via jumpers S4, S5 closed
(S6, S7, S9 closed, S8 open)

RS485 4-wires

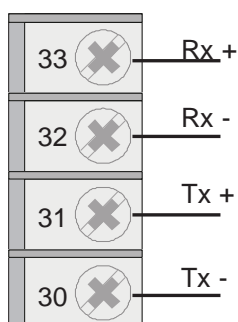

termination strength 120 Ω line can be inserted via jumper S3 closed (Tx) and S2 closed (Rx)

Polarization can be inserted on Rx via jumpers S4, S5 closed
(S6, S7, S9 open, S8 closed)

RS232

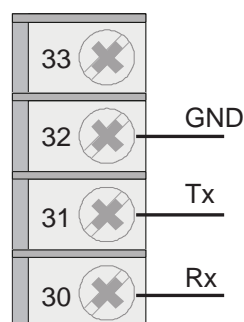

SER/W Board

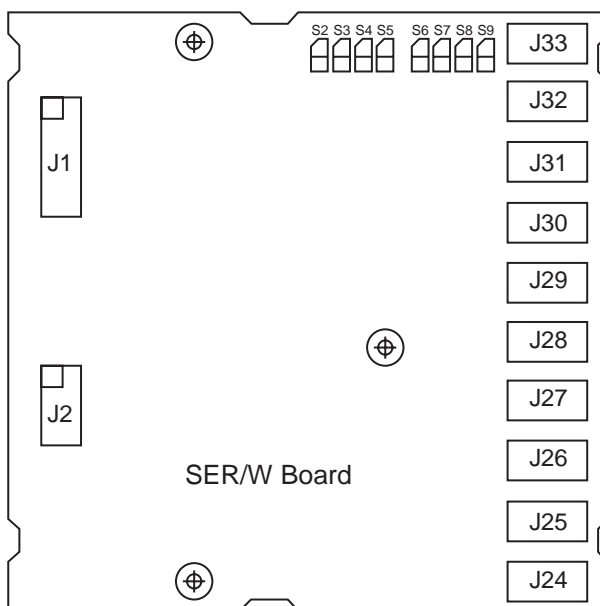

Power supply

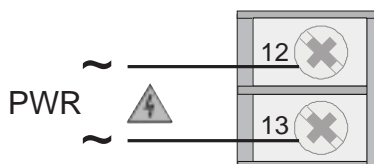

Standard: 100...240Vac/dc $\pm 10\%$
Optional: 20...27Vac/dc $\pm 10\%$
Power: max 20VA; 50/60 Hz

3 • FUNCTIONS

 This section describes the use and functions of the displays, lighted indicators and buttons making up the instrument 2400 operator interface.

It therefore contains essential information for correct programming and configuration of the controllers.

Operator interface



ID	Symbol	Function
1		PV : Displays the process variable, identifies menus, identificative, parameter values and error codes
2		F: Displays the index value for the variable shown on the PV display, units of measurement defined in configuration
3		<p>Raises/Lowers the value of the parameter displayed in SV until the max/min value is reached. When kept pushed: progressively increases the raise/lower speed of the value displayed.</p> <p>Lets you navigate the menus and parameters. Confirms the value of the current (or modified by) parameter and selects the next parameter.</p> <p>Buttons (for configuration, see parameter <i>but1</i>, <i>but2</i>, <i>but3</i> on <i>Hrd</i> menu)</p> <p>Standard configuration:</p> <ul style="list-style-type: none"> activation maximum peak input IN1 check calibration strain-gauge input IN1 disabled (no function) <p>The functions are active only when the 1 display shows the process variable at level 1</p>
		Confirms the value of the current (or modified by) parameter and selects the preceding parameter.
4		alarm state indicators: ON OFF
5		Function indicators: for configuration, see parameter <i>LEd1</i> , <i>LEd2</i> , <i>LEd3</i> , <i>LEd4</i> on <i>Hrd</i> menu. Standard configuration: L1 = ON (displays max. peak IN1) L2 = ON (automatic calibration control IN1) L3 = ON (DI1 on) repeat DI1 OFF (DI1 off) L4 = ON (DI2 on) repeat DI2 OFF (DI2 off)

General Notes on Operation

Switching on and operating the controller

Self-diagnostics

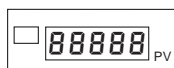

- When switched on, the controller runs a self-diagnostics test. During the test, all segments of the display and the 7 lighted indicators flash.
- If self-diagnostics detects no errors, the controller enters normal operating state (Level 1).
- Any errors detected by self-diagnostics are stored in a register and can be displayed with the *Err* function on the *InF* menu.

Normal operation Level 1

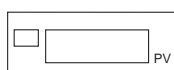

- PV displays the Process Variable value.
- Push briefly **F** to see, in sequence, on the display (and change if necessary) the significant values that influence operation of the controller at Level 1 (Alarm Setpoint)
 - When the button **F** remains pushed for 3 seconds, you enter the Programming/Configuration menu – see Navigating the Controller Menus for details.
 - Push to **▲** **▼** the Setpoint value until reaching the required value.
 - Switching between net and gross values from keyboard and from digital inputs. Display of gross value is indicated by the flashing decimal point of the ones.

Errors during operation

In case of errors during normal operation PV Displays error code.

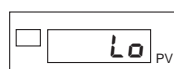

Lo Process Variable < min. scale limit (parameter *Lo5* on *InP* menu of selected Process Variable)

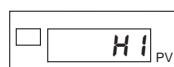

Hi Process Variable > max. scale limit (parameter *Hi5* on *InP* menu of selected Process Variable)

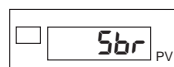

Sbr probe broken or input values exceed maximum limits

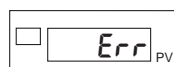

Err PT100 in short circuit and input values below minimum limits (ex. for CT with wrong connection)
4...20mA transmitter broken or not powered

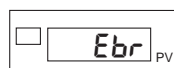

Ebr absence of probe power supply (strain-gauge) due to broken or unconnected probe

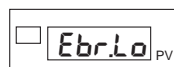

EbrLo no voltage in probe power supply

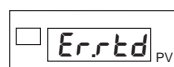

Errtd third wire for PT100 broken or not connected

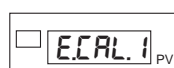

E.CAL.x calibration error on input x (x = 1...4)



To solve the problem, see: Guide to the Solution of Problems in Section 6 Maintenance.

Navigating the Indicator/Interceptor Menus

Keep this button **F** pushed to scroll the menus in succession; release when the required menu appears.
 Push **F** to access the parameters of the selected menu.
 Keep + pushed **F**  to return immediately to level 1.

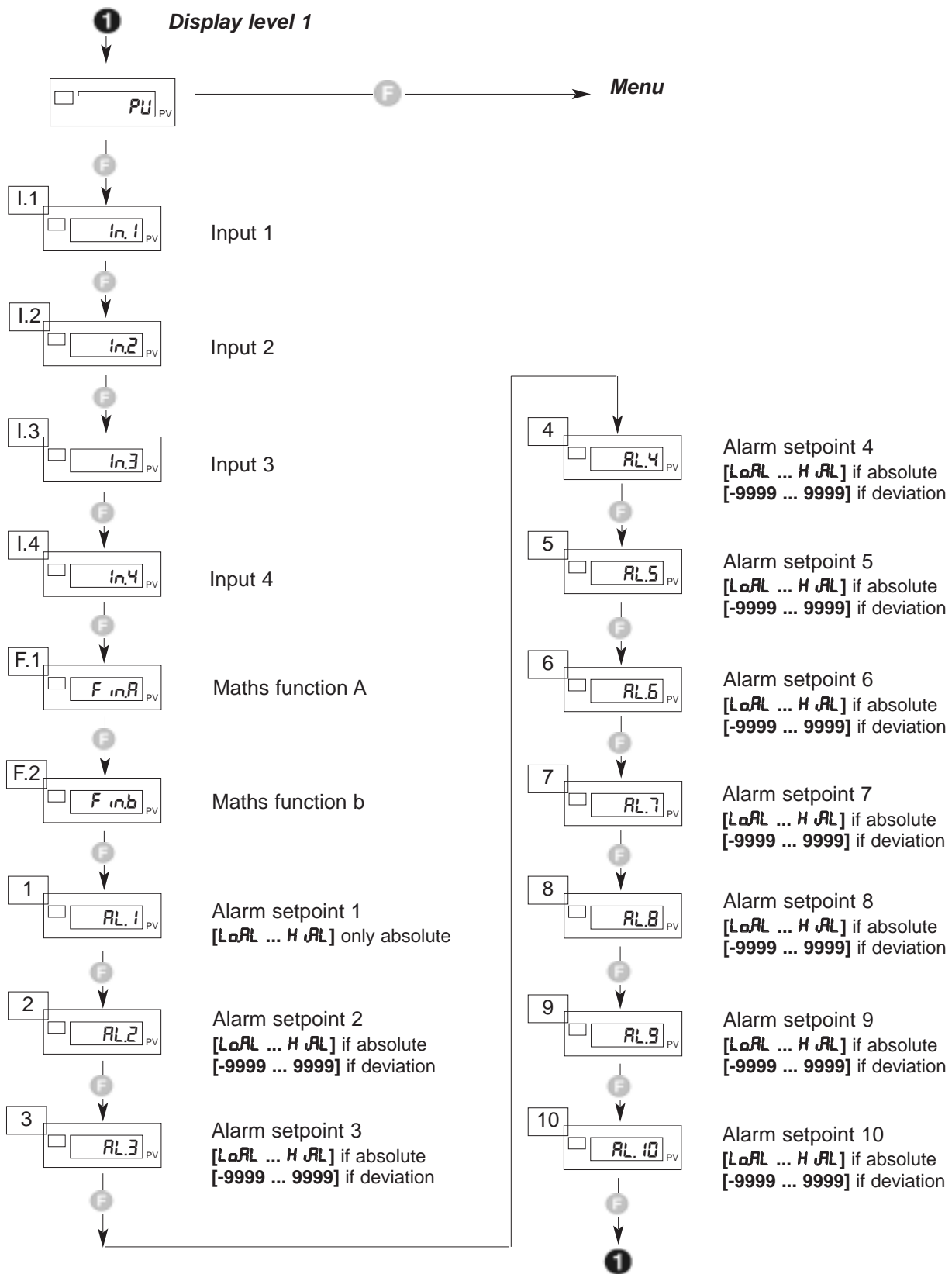

Insignificant configuration parameters and menus are NOT displayed.

*The display returns to level 1 if the keys   **F** are not pressed within about 15 seconds*

Menu

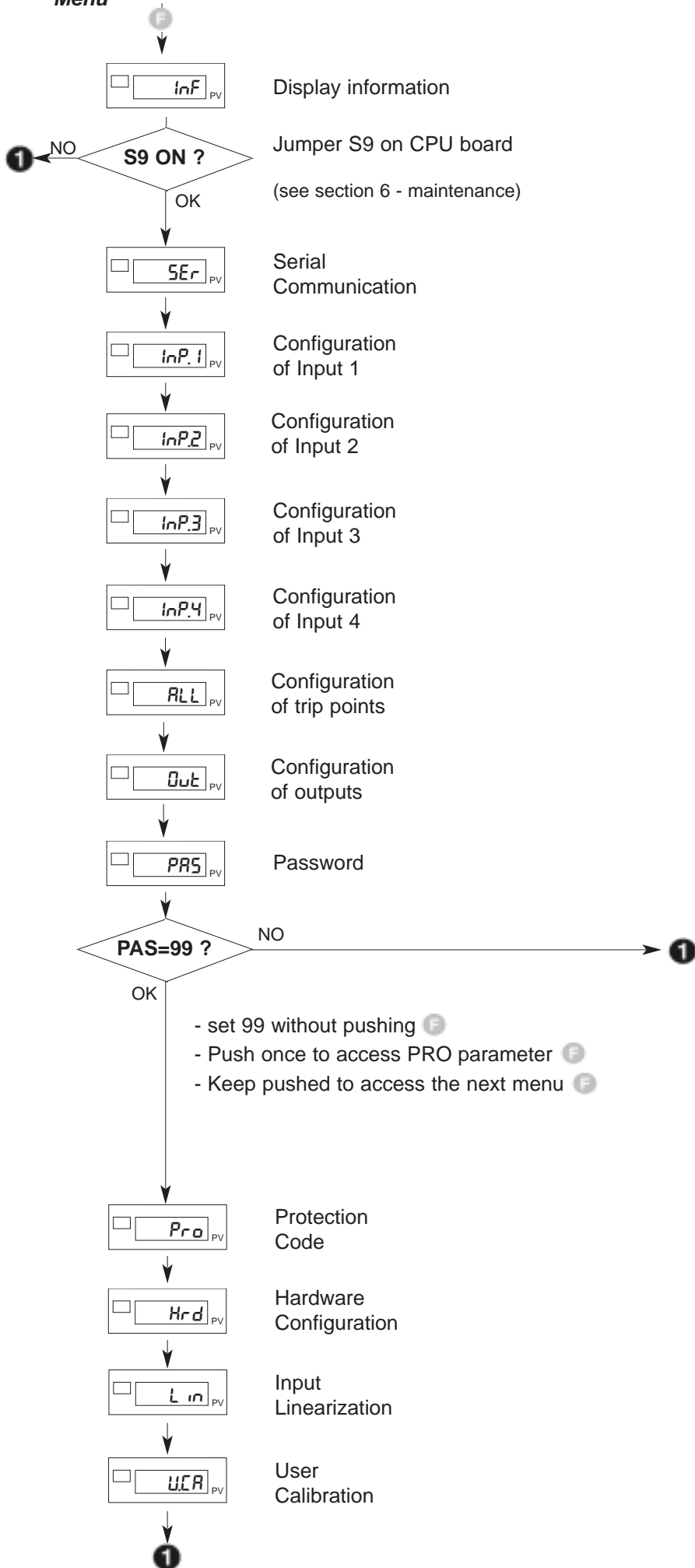

 This section contains the instructions needed to configure the instrument 2400 as required.

To provide optimum functioning in its intended application, the instrument 2400 control parameters have to be correctly configured and programmed.

The flexibility and high performance of these instruments is based on numerous parameters that the user can program directly via the control panel buttons, or transfer from PC in the form of configuration file via the optional RS485 interface.

Configuration

Access to all configuration / programming menus and to all parameters available means that the Controller can be configured extremely precisely to satisfy any applicative requirement.

 The correct setting of configuration parameters assumes expertise in control problems and techniques. Therefore, do not change these parameters if you are not fully aware of the consequences that may derive from improper setting.



To prevent harm to persons or property, the user is responsible for checking that all parameters are correctly set before the instrument is put into operation.

 If you have any doubts or need any explanation, consult the website www.gefran.com or call Gefran Customer Care.

The following pages describe each of the instrument 2400 menus and, for each parameter, provide a concise description of its function, its default value (if any), and its range of settable values.

Supplemental Notes for Consultation of Configuration/Programming Pages

When setting a few highly complex parameters, you need to consult certain tables or detailed notes.

These tables or notes are found on the right side of the page for the parameter in question.

Applicative Notes





Detailed explanations of certain operating modes or special techniques developed by Gefran in its years of experience in the control field are provided at the end of the Configuration/Programming Section, and are a valuable consulting tool for the user.

References are made to these Applicative Notes, where necessary, in the configuration / programming flows.

Password: PR5

The message *PR5* appears when scrolling the menus (button  kept pushed), after the *OUT* menu.

Subsequent menus can be accessed only by setting the parameter *PR5* = 99, then pushing  .

After setting the value 99, push and keep pushed  to access subsequent menus.

Protection Code: Pr0

The *Pr0* parameter lets you enable or disable the display and/or change of certain parameters.

For details, see the description of the *Pr0* parameter in the configuration flows.

Jumper S9 on CPU Board

The absence of jumper S9 on the CPU board blocks access to all menus when the instrument's hardware configuration does not require any change of preset parameters.

This jumper is inserted or removed in the factory, and normally does not need to be changed by the final user.

For more information, see section 6 - Maintenance.

This menu lets you display the state of the instrument

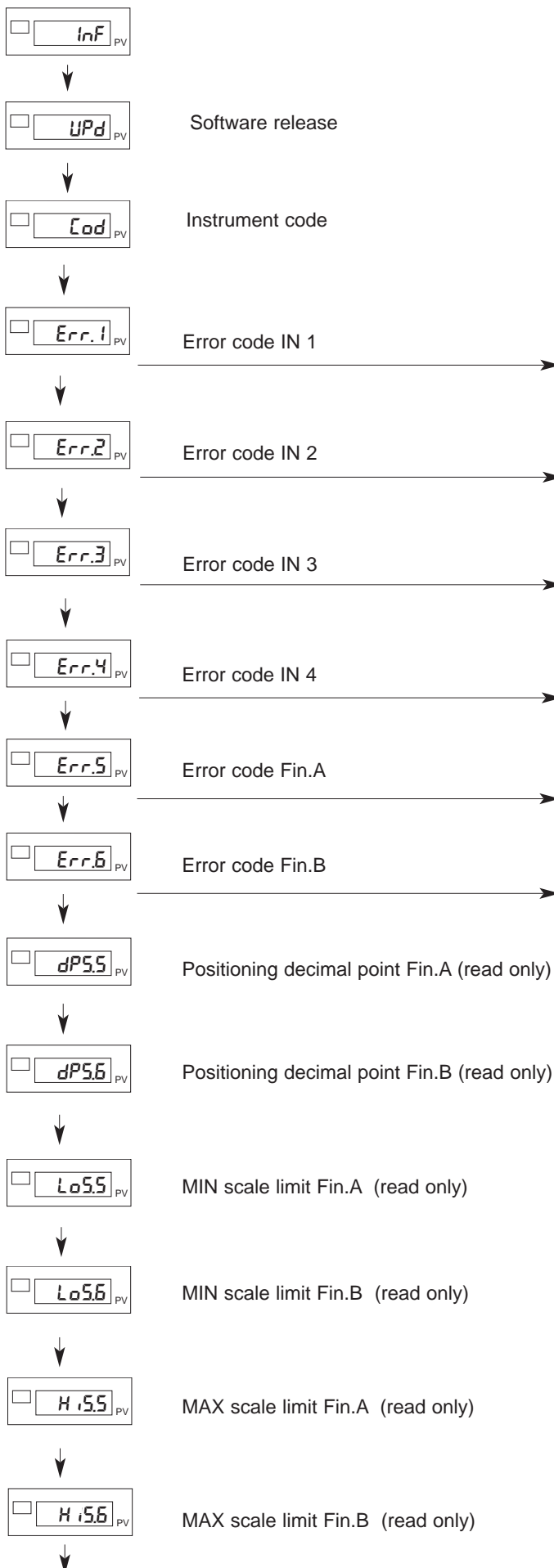

0	no error
1	Lo
2	Hi
3	Err
4	Sbr
5	Ebr
6	Ebr.Lo
7	Er.rtd
8	Er.CAL

See: General notes on operation

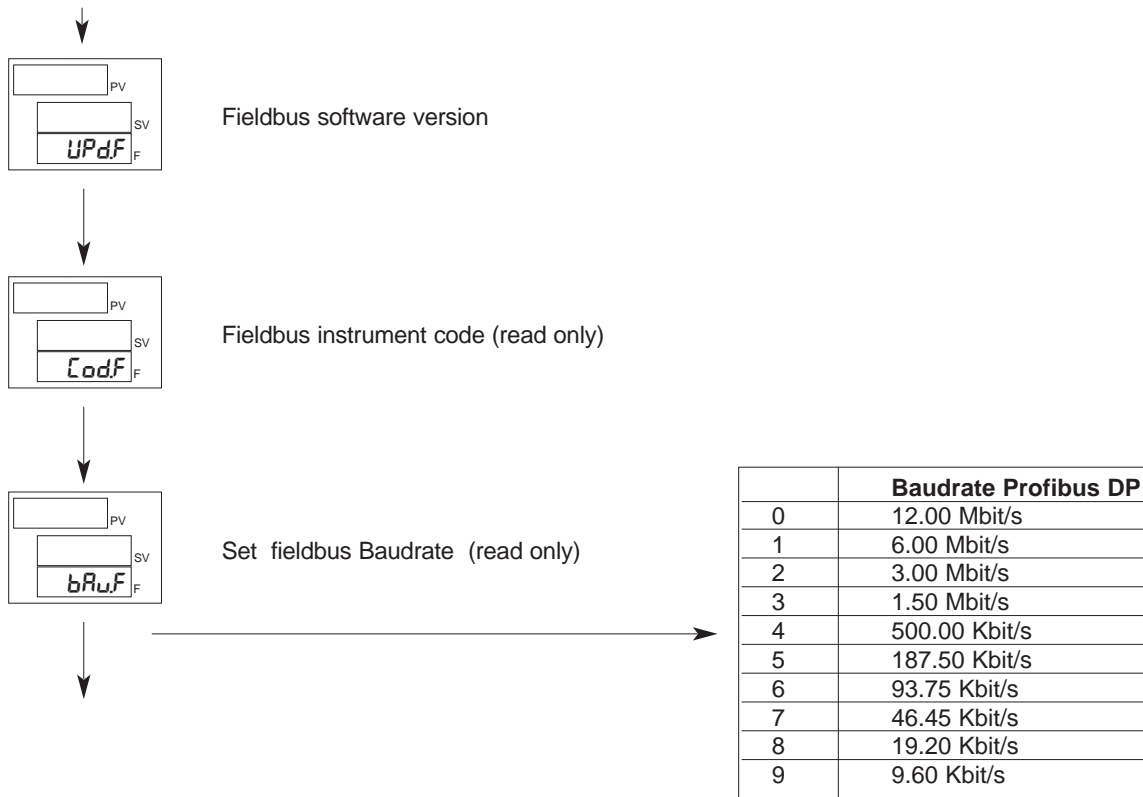

SEr Serial Communication

This menu lets you configure the various parameters that control serial communication between instrument and supervisor.

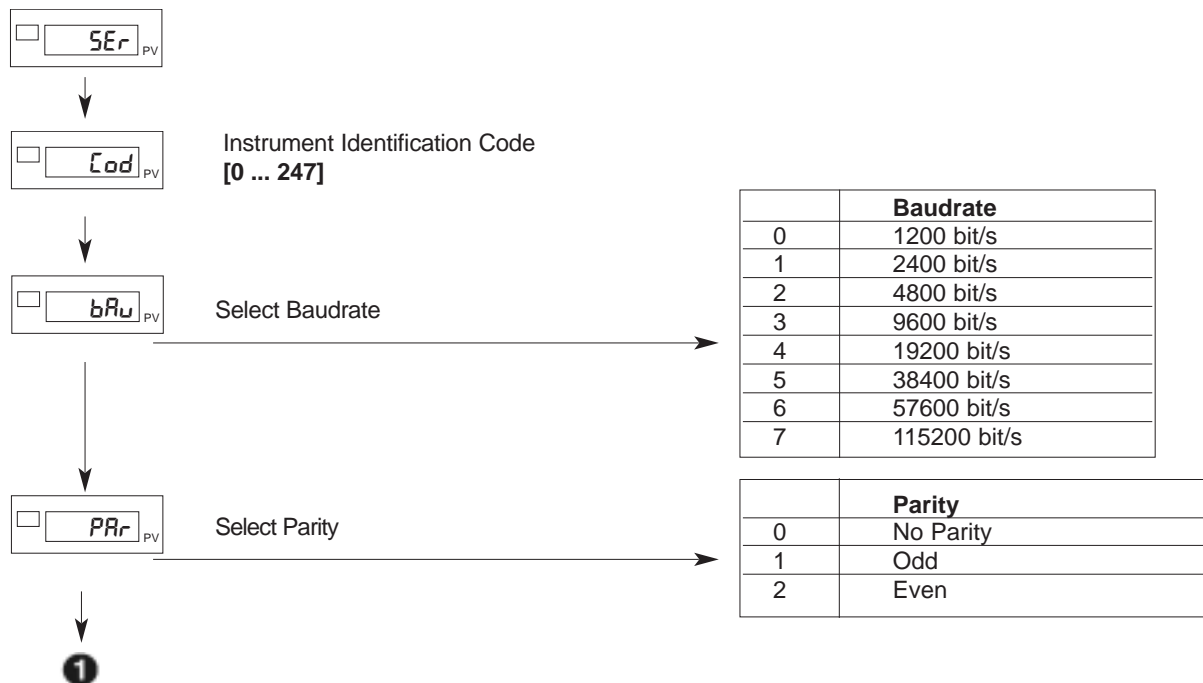

InP.1 Setting Input 1

This menu lets you configure parameters for the input 1 signals

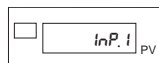

Probe type, signal, enable custom linearization, and main input scale.

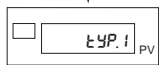

	Probe type	Scale limits
0	Input disabled	
1	TC J °C	0/1000
2	TC J °F	32/1832
3	TC K °C	0/1300
4	TC K °F	32/2372
5	TC R °C	0/1750
6	TC R °F	32/3182
7	TC S °C	0/1750
8	TC S °F	32/3182
9	TC T °C	-200/400
10	TC T °F	-328/752
11	PT100 °C	-200/850
12	PT100 °F	-328/1562

	Probe type	Scale limits
13	Potentiometer ≥100Ω with 2.5V power supply	-19999/99999
14	Strain gauge positive polarization sensitivity: 1.5 ... 4mV/V	-19999/99999
15	Strain gauge symmetrical polarization sensitivity: 1.5 ... 4mV/V	-19999/99999
16	60mV	-19999/99999
17	±60mV	-19999/99999
18	100mV	-19999/99999
19	±100mV	-19999/99999
20	1V	-19999/99999
21	±1V	-19999/99999
22	5V	-19999/99999
23	±5V	-19999/99999
24	10V	-19999/99999
25	±10V	-19999/99999
26	0...20 mA	-19999/99999
27	4...20 mA	-19999/99999
28	Strain-gauge positive polarization calibrated 40mV	-19999/99999
29	Strain-gauge symmetrical polarization calibrated 40mV	-19999/99999

+32 with custom linearization
+64 only for cold junction compensation thermocouples

Note

- For input type 27 (4...20mA), a current below 2mA causes the Err and activates the assigned relay state specified with parameter rEL.
- The type 28, 29, 30, 31 input can be used without having to calibrate the probe. Simply enter the Offset and Sensitivity data requested in configuration (ex.: 0.193mV; 1.985mV/V).
- For types 28, 29 Maximum sensitivity is 4mV/V with 10V power supply.
- For types 30, 31 Maximum sensitivity is 6mV/V with 10V power supply.

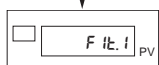

Input 1 Digital Filter
[0.00 ... 20.00] sec

If set to "0" the average filter is excluded on the sampled value

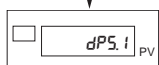

Decimal Point Position for Scale Input 1

	Size
0	xxxxx
1	xxxx.x
2	xxx.xx (*)
3	xx.xxx (*)
4	x.xxxx (*)

(*) **Not** available for TC, RTD probes

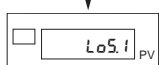

MIN Scale Limit Input 1

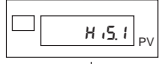

MAX Scale Limit Input 1

+8 disables the Lo and Hi messages for linear inputs only
+16 disables the Ebr message
+32 for differential linear inputs probe type 16...25
Min...Max value assigned to input selected with parameter tYP.1

N.B.:

the scale limits can be reversed for linear inputs only

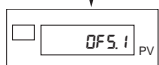

Offset Correction Input 1
[-999 ... +999] scale points



Offset Input 1
[-9.999 ... +9.999] mV



Sensitivity Input 1
[-0.000 ... +9.999] mV/V

Only for probe type 28, 29



inP.2 Setting Input 2

This menu lets you configure parameters for the input 2 signals

inP.2 PV

Probe type, signal, enable custom linearization, and main input scale.

$\epsilon Y P.2$ PV

	Probe type	Scale limits
0	Input disabled	
1	TC J °C	0/1000
2	TC J °F	32/1832
3	TC K °C	0/1300
4	TC K °F	32/2372
5	TC R °C	0/1750
6	TC R °F	32/3182
7	TC S °C	0/1750
8	TC S °F	32/3182
9	TC T °C	-200/400
10	TC T °F	-328/752
11	PT100 °C	-200/850
12	PT100 °F	-328/1562

	Probe type	Scale limits
13	Potentiometer $\geq 100\Omega$ with 2.5V power supply	-19999/99999
14	Strain gauge positive polarization sensitivity: 1.5 ... 4mV/V	-19999/99999
15	Strain gauge symmetrical polarization sensitivity: 1.5 ... 4mV/V	-19999/99999
16	60mV	-19999/99999
17	± 60 mV	-19999/99999
18	100mV	-19999/99999
19	± 100 mV	-19999/99999
20	1V	-19999/99999
21	± 1 V	-19999/99999
22	5V	-19999/99999
23	± 5 V	-19999/99999
24	10V	-19999/99999
25	± 10 V	-19999/99999
26	0...20 mA	-19999/99999
27	4...20 mA	-19999/99999
28	Strain-gauge positive polarization calibrated 40mV	-19999/99999
29	Strain-gauge symmetrical polarization calibrated 40mV	-19999/99999

+32 with custom linearization
+64 only for cold junction compensation thermocouples

Note

- For input type 27 (4...20mA), a current below 2mA causes the *Err* and activates the assigned relay state specified with parameter *-rEL*.
- The type 28, 29, 30, 31 input can be used without having to calibrate the probe. Simply enter the Offset and Sensitivity data requested in configuration (ex.: 0.193mV; 1.985mV/V).
- For types 28, 29 Maximum sensitivity is 4mV/V with 10V power supply.
- For types 30, 31 Maximum sensitivity is 6mV/V with 10V power supply.

$F \# \epsilon.2$ PV

Input 2 Digital Filter
[0.00 ... 20.00] sec

If set to "0" the average filter is excluded on the sampled value

$dP5.2$ PV

Decimal Point Position for Scale Input 2

	Size
0	xxxxx
1	xxxx.x
2	xxx.xx (*)
3	xx.xxx (*)
4	x.xxxx (*)

(*) Not available for TC, RTD probes

$L \sigma 5.2$ PV

MIN Scale Limit Input 2

+8 disables the *L_o* and *H_i* messages for linear inputs only
+16 disables the *Ebr* message
+32 for differential linear inputs probe type 16...25

$H \# 5.2$ PV

MAX Scale Limit Input 2

Min...Max value assigned to input selected with parameter $\epsilon Y P.2$

N.B.:

the scale limits can be reversed for linear inputs only

$\theta F 5.2$ PV

Offset Correction Input 2
[-999 ... +999] scale points

$SG \theta F.2$ PV

Offset Input 2
[-9.999 ... +9.999] mV

Only for probe type 28, 29

$SGSE.2$ PV

Sensitivity Input 2
[-0.000 ... +9.999] mV/V



InP.3 Setting Input 3

This menu lets you configure parameters for the input 3 signals.

InP.3 PV

tYP.3 PV

Probe type, signal, enable custom linearization, and main input scale

	Probe type	Scale limits
0	Input disabled	
1	0...10V	-19999/99999
2	0...20mA	-19999/99999
3	4...20mA	-19999/99999
4	potentiometer	-19999/99999

+32 enable custom linearization

Filt.3 PV

Input 3 Digital Filter
[0.00 ... 20.00] sec

If set to "0" the average filter is excluded on the sampled value

dPS.3 PV

Decimal Point Position for Scale
Input 3

	Size
0	xxxxx
1	xxxx.x
2	xxx.xx
3	xx.xxx
4	x.xxxx

+8 disables the L_o and H_i messages

LoS.3 PV

MIN Scale Limit Input 3

HiS.3 PV

MAX Scale Limit Input 3

Min...Max value assigned to input selected with parameter tYP.3

N.B.:
the scale limits can be reversed

OFS.3 PV

Offset Correction Input 3
[-999 ... +999] scale points

1

inP.4 Setting Input 4

This menu lets you configure parameters for the input 4 signals.

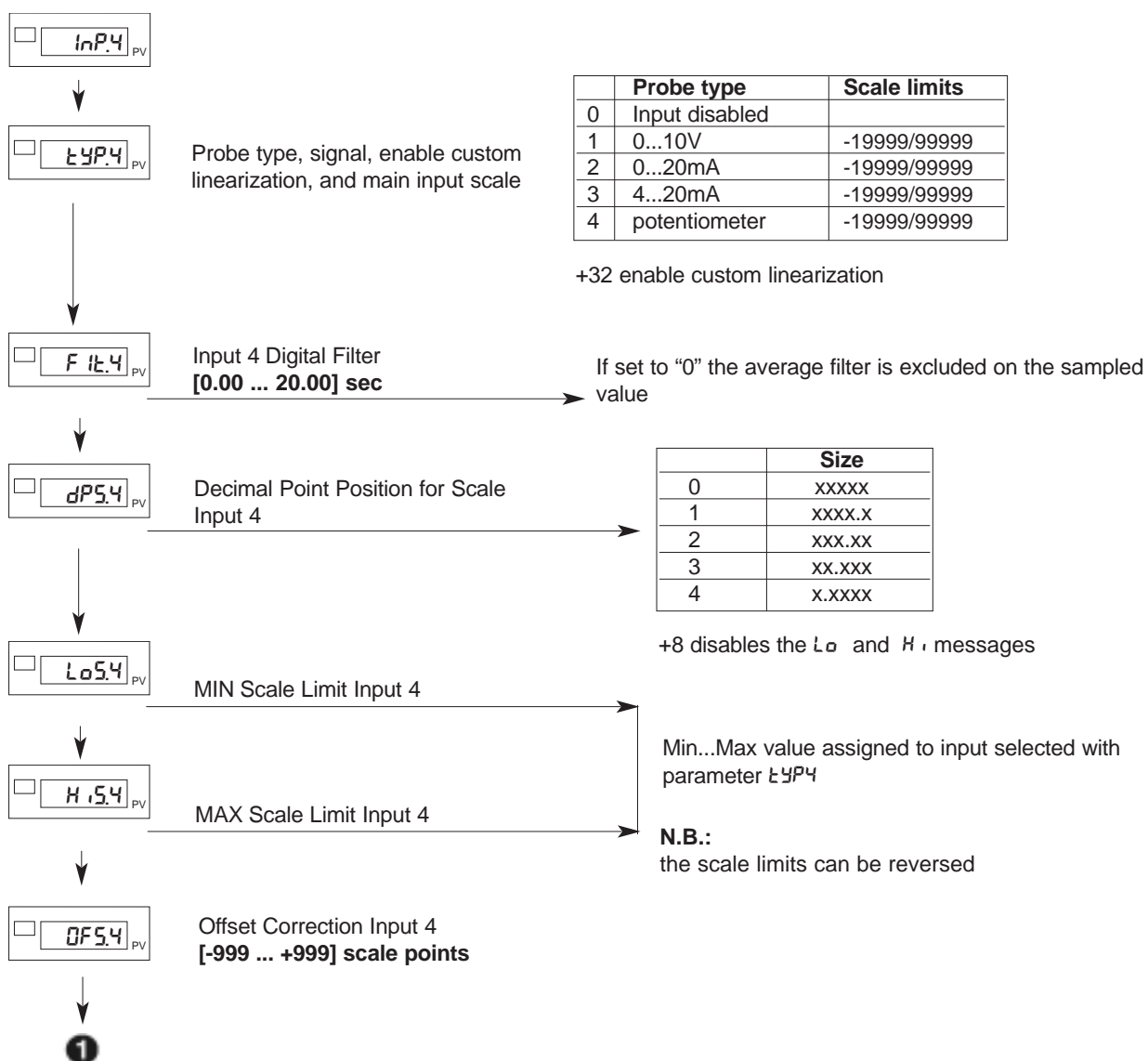

RLI Setting Alarms

This menu lets you configure parameters for the alarm functions.

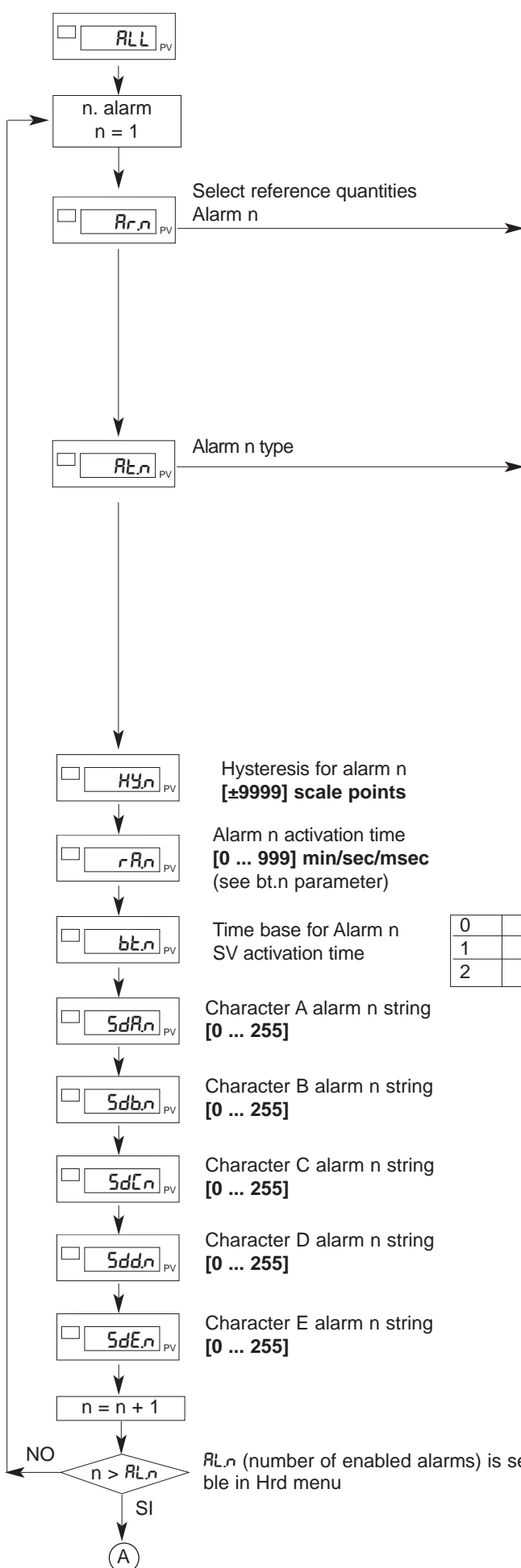

	Reference quantity
0	IN1
1	IN2
2	IN3
3	IN4
4	Fin.A (math function A)
5	Fin.b (math function b)
12	Value acquired from serial line
13	Input 1 maximum peak
14	Input 1 minimum peak
15	Input 1 peak - peak
16	Input 2 maximum peak
17	Input 2 minimum peak
18	Input 2 peak - peak

+32 only for AL1 and AL2 : deviation alarm limit In.3 and In.4 from digital input (diG.1,2 codes: 4, 5, 6)

	Direct (maximum) Inverse (minimum)	Absolute/Relative	Normal Symmetrical (window)
0	Direct	Absolute	Normal
1	Inverse	Absolute	Normal
2	Direct	Relative	Normal
3	Inverse	Relative	Normal
4	Direct	Absolute	Symmetrical
5	Inverse	Absolute	Symmetrical
6	Direct	Relative	Symmetrical
7	Inverse	Relative	Symmetrical

Alarm 1 is only absolute

The deviation alarm refers to the previous absolute.

by adding the following numbers to the value shown in the table, you can enable a series of supplemental functions:

- +8: disable power-on until first trip point.
- +16: enable memory latch.
- +32: change color of PV display in case of active alarm
- +64: deviation alarm refers to input IN3 (except code Rr.n = 2)
- +128: deviation alarm refers to input IN3 (except code Rr.n = 3)
- +256: change color of PV display if limit is exceeded (only for alarms with timed delay)
- +512: enable string if alarm is active
- +1024: enable string if limit is exceeded (only for alarms with timed delay)

N.B.:

For deviation alarms, reference quantities must have the same decimal resolution

0	msec
1	sec
2	min

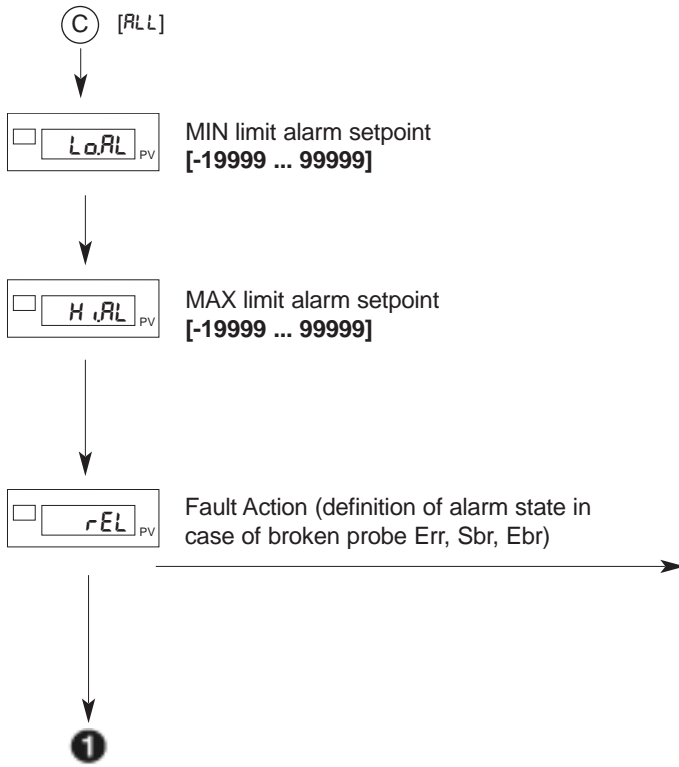

Alarm 3			
0	OFF	OFF	OFF
1	ON	OFF	OFF
2	OFF	ON	OFF
3	ON	ON	OFF
4	OFF	OFF	ON
5	ON	OFF	ON
6	OFF	ON	ON
7	ON	ON	ON

State of alarms 4...10 = OFF
 +16 for state of alarms 4...10 = ON

Out Setting Outputs

This menu lets you configure the output parameters.

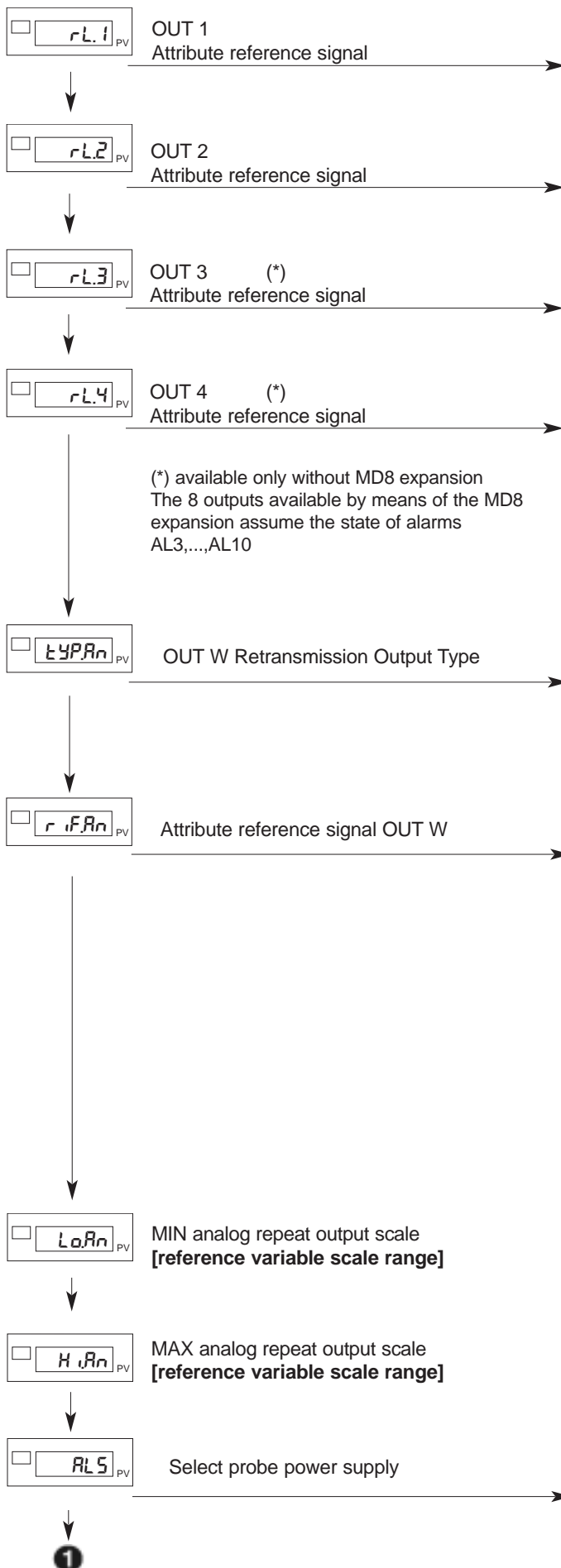

	Function
0	OFF
1	AL1 – alarm 1
2	AL2 – alarm 2
3	AL3 – alarm 3
5	Repeat logic input 1
6	Repeat logic input 2
7	Repeat but 1 key
8	AL1 or AL2
9	AL1 or AL2 or AL3
10	AL1 And AL2
11	AL1 and AL2 and AL3
16	or AL3 ... AL10
17	and AL3 ... AL10
18	AL 4 – alarm 4
19	AL4 or AL5
20	AL4 or AL5 or AL6
21	AL4 or AL5 or AL6 or AL7
22	AL4 and AL5
23	AL4 and AL5 and AL6
24	AL4 and AL5 and AL6 and AL7
25	AL8 or AL9
26	AL8 or AL9 or AL10
27	AL8 and AL9
28	AL8 and AL9 and AL10

Add +32 to the values indicated in the table to obtain the denied logic level in output, or reverse for CO1, CO2.

0	Output disabled
1	0...10V
2	2...10V
3	0...20mA
4	4...20mA
5	±10V

+8 reverse output

	Reference quantity
0	IN1
1	IN2
2	IN3
3	IN4
4	Fin.A (math function A)
5	Fin.b (math function b)
12	Value acquired from serial line
13	Input 1 maximum peak
14	Input 1 minimum peak
15	Input 1 peak-peak
16	Input 2 maximum peak
17	Input 2 minimum peak
18	Input 2 peak-peak
19	AL1 (limit)
20	AL2 (limit)
21	AL3 (limit)

+32 only for riF.An = 0,1,2,3,4,5: output at max/min hardware (beyond calibration limits) for input at Hi/Lo

+64 only for riF.An = 0,1,2,3,4,5: output at minimum if input is in Err, Sbr, Ebr condition

0	2,5V for potentiometers
1	5V for strain gauge
2	10V for strain gauge

max. 200mA

Pro Protection Code

This menu lets you enable/disable the display and/or change of certain parameters.
(To access this menu, see the section “Using the controller menus”)

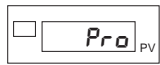

	Display	Change
0	<i>in.1, in.2, in.3, in.4</i> <i>F in.A, F in.B,</i> <i>RL.1, RL.2, RL.3, ... RL.10</i>	<i>RL.1, RL.2, RL.3</i> <i>RL.4, ... RL.10</i>
1	<i>in.1, in.2, in.3, in.4</i> <i>F in.A, F in.B,</i> <i>RL.1, RL.2, RL.3, ... RL.10</i>	
3	<i>F in.A, F in.B,</i>	

by adding the following numbers to the value shown in the table,
you can enable a series of supplemental functions:

- +4: disable menus *in.P.1, in.P.2, in.P.3, in.P.4, RL.L, Out*
- +8: disable menus *SEr*
- +16: disable software “on – off” from keyboard
- +32: disable save tare

1

Hrd Hardware Configuration

This menu lets you configure the hardware parameters.
(To access this menu, see the section “Using the controller menus”).

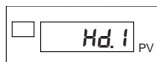
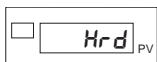

Process type and line frequency,
enable MD8 module

	Process type	Line frequency
0	Fast	50Hz
2	Slow	50Hz
4	Fast	60Hz
6	Slow	60Hz

- +8: digital inputs DI1, DI2, type NPN.
digital inputs NPN is on with open contact.
If you want reverse logic, set +64 in parameter *d iux*
- +16: enable MD8 expansion control
- + 32: disable menu rEL

A

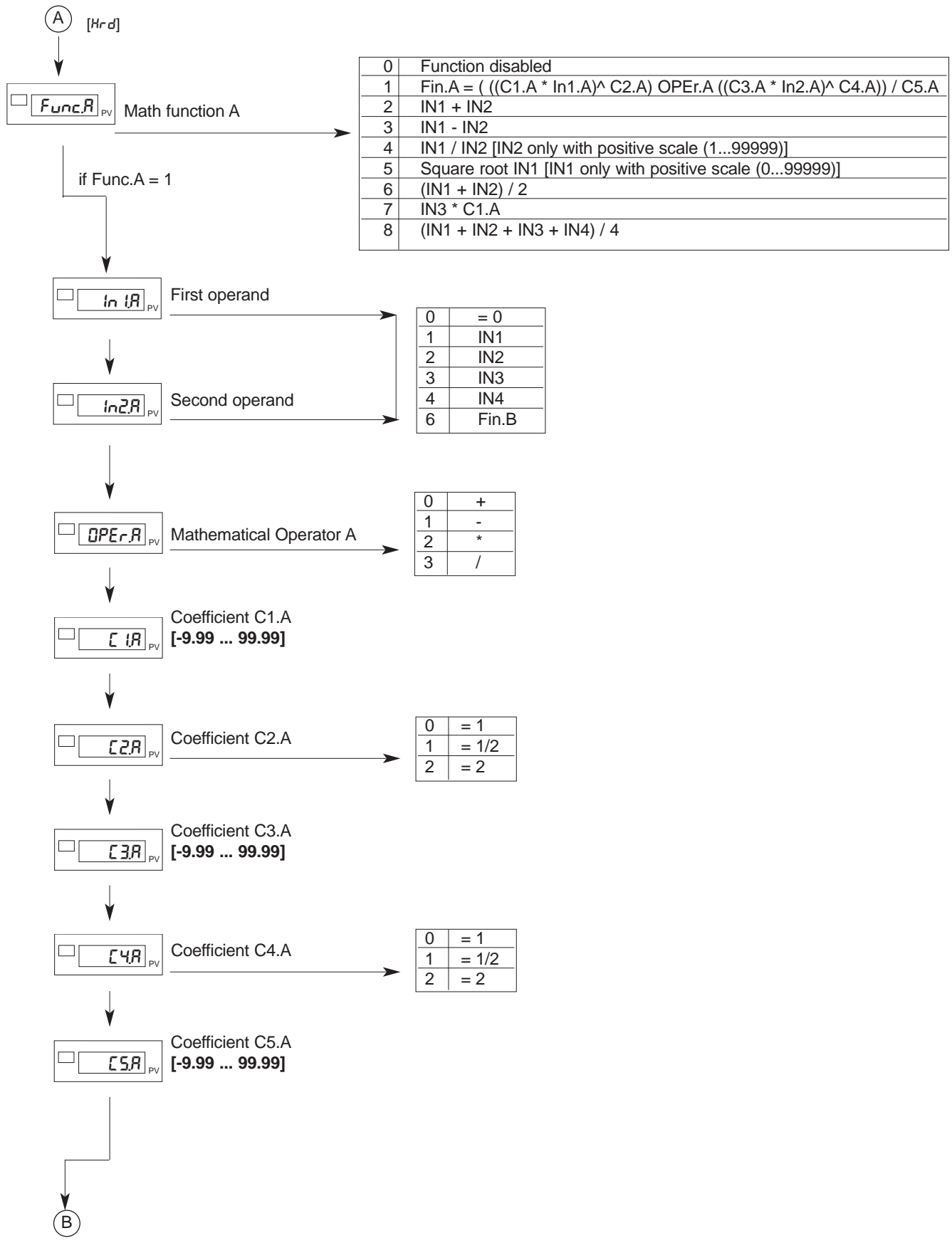

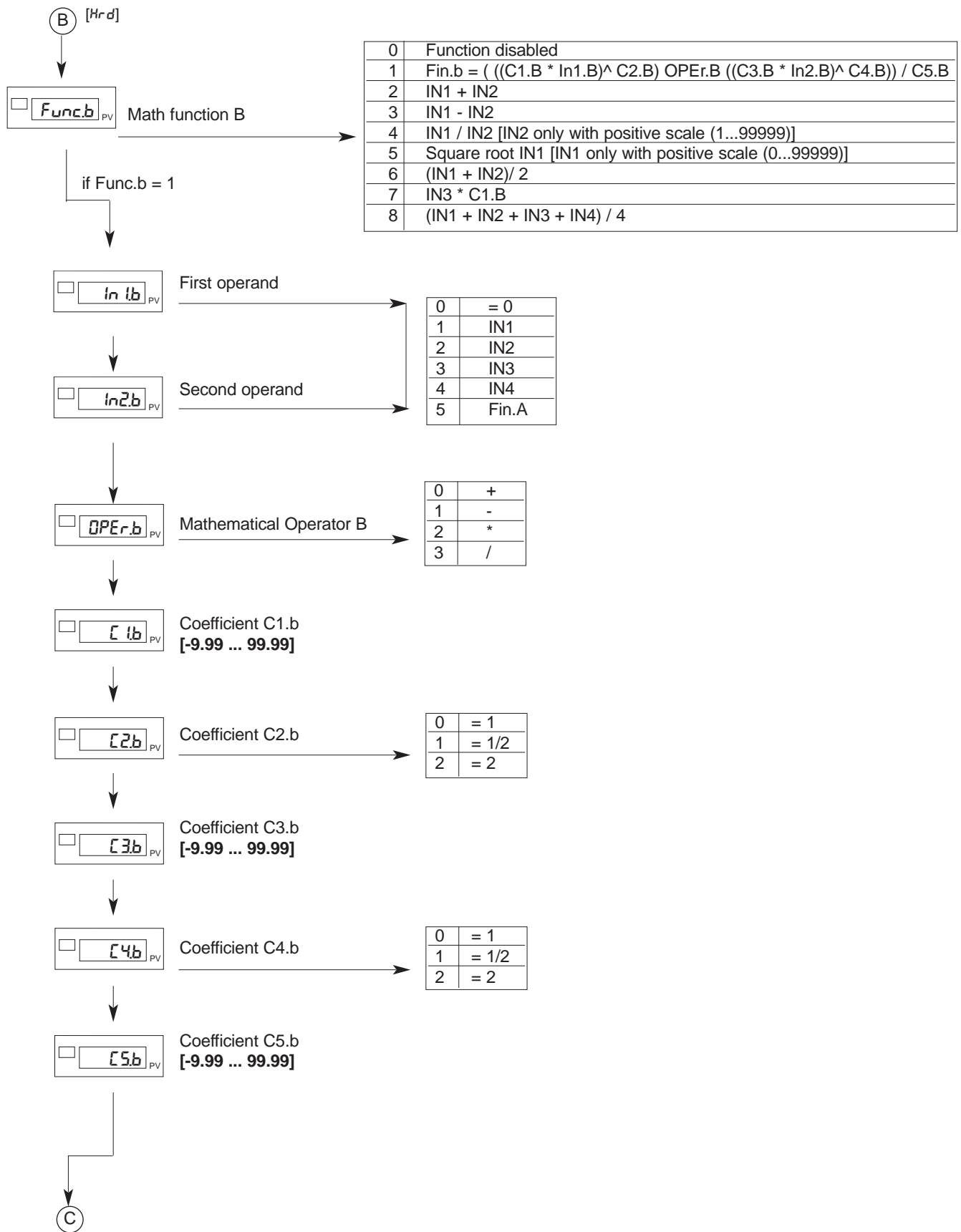

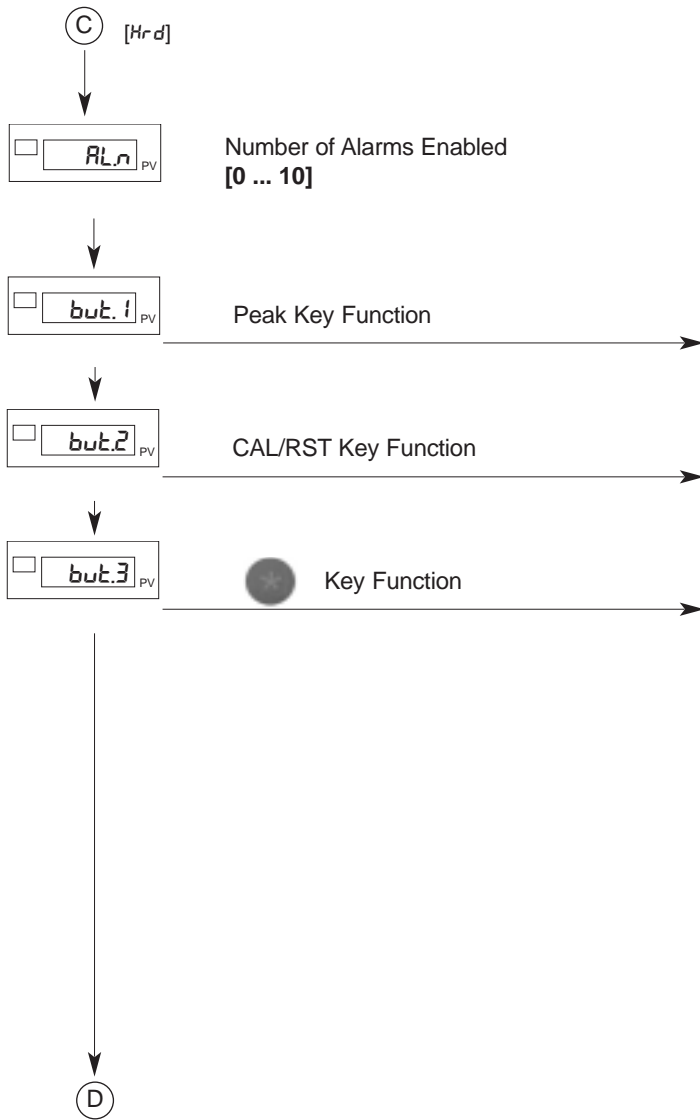



	Function
0	Disabled (no function)
2	HOLD IN1
3	Reset memory latch
7	Set / Reset outputs OUT 1 ... OUT 4 (for but.1 only)
8	Peak ON + (maximum) IN1
9	Peak ON - (minimum) IN1
10	Peak ON - peak (maximum peak - minimum peak) IN1
11	Reset memory peak IN1
12	Reset alarms / peak IN1
15	Check calibration strain-gauge IN1 (6-wire probe)
16	Calibrate strain-gauge IN1
17	U.CAL calibration (from version 1.44)
23	Zero tare IN1
24	Zero tare IN1 / Reset alarm latch
25	Zero tare IN1 / Reset peak latch IN1
26	Zero tare IN1 / Reset alarm latch / Reset peak latch IN1
27	Display HOLD
28	FLASH IN1
29	Net / Gross IN1 (display of gross value is indicated by the flashing decimal point of the ones)

+32 to refer to input IN2. (only for values on table referred to IN1)

for but3 only, adding +64 to value shown in table, disable "back menu" function (immediate exit from configuration menus with key combination  + ).

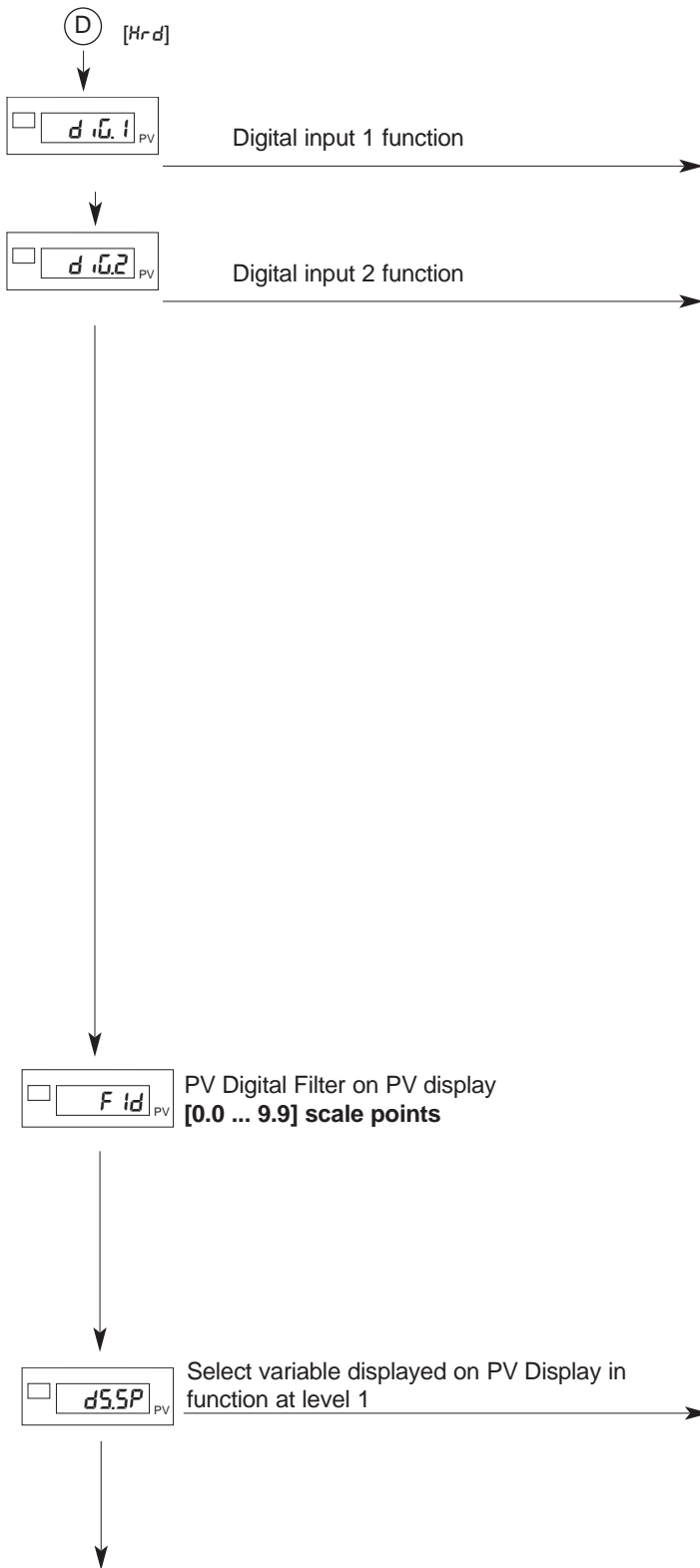

	Function
0	Disabled (no function)
2	HOLD IN1
3	Reset alarm latch
4	Alarm limit 1 from input In.3
5	Alarm limit 2 from input In.4
6	Alarm limit 1 from input In.3 and alarm limit 2 from input In.4
7	Set / Reset outputs OUT 1 ... OUT 4
8	Peak ON + (maximum) IN1
9	Peak ON - (minimum) IN1
10	Peak ON - peak (maximum peak - minimum peak) IN1
11	Reset memory peak IN1
12	Reset memory alarms / peak IN1
13	Selection IN.1...IN/4 for visualization on display PV (Lsb)
14	Selection IN.1...IN/4 for visualization on display PV (msb)
15	Check calibration strain-gauge IN1 (6-wire probe)
16	Calibration strain-gauge IN1
17	Software off/on
18	Block key
19	Remoting key F
20	Remoting key INC
21	Remoting key DEC
23	Zero tare IN1
24	Zero tare IN1 / Reset alarm latch
25	Zero tare IN1 / Reset peak latch IN1
26	Zero tare IN1 / Reset alarm latch / Reset peak latch IN1
27	Display HOLD IN1
28	FLASH IN1
29	Net / Gross (if on = Gross)
30	Change color of PV display

By adding the following numbers to the value shown in the table, you can enable a series of supplemental functions:
 +32: to refer to input IN2 (only for values on table referred to IN1)
 +64: input in denied logic
 +128: force logic state 1 (ON)

	Function
1	IN1
2	IN2
3	IN3
4	IN4
8	Retransmission output
9	F InR
10	F Inb
12	Selection IN.1...IN.4 from digital inputs
32	Alternation of IN1, IN2 (with time approx. 1.2 sec)
64	Alternation of IN1, IN2, IN3 (with time approx. 1.2 sec)
128	Alternation of IN1, IN2, IN3, IN4 (with time approx. 1.2 sec)

+16 green PV display
 + 256 Alternating with the time 2,4sec

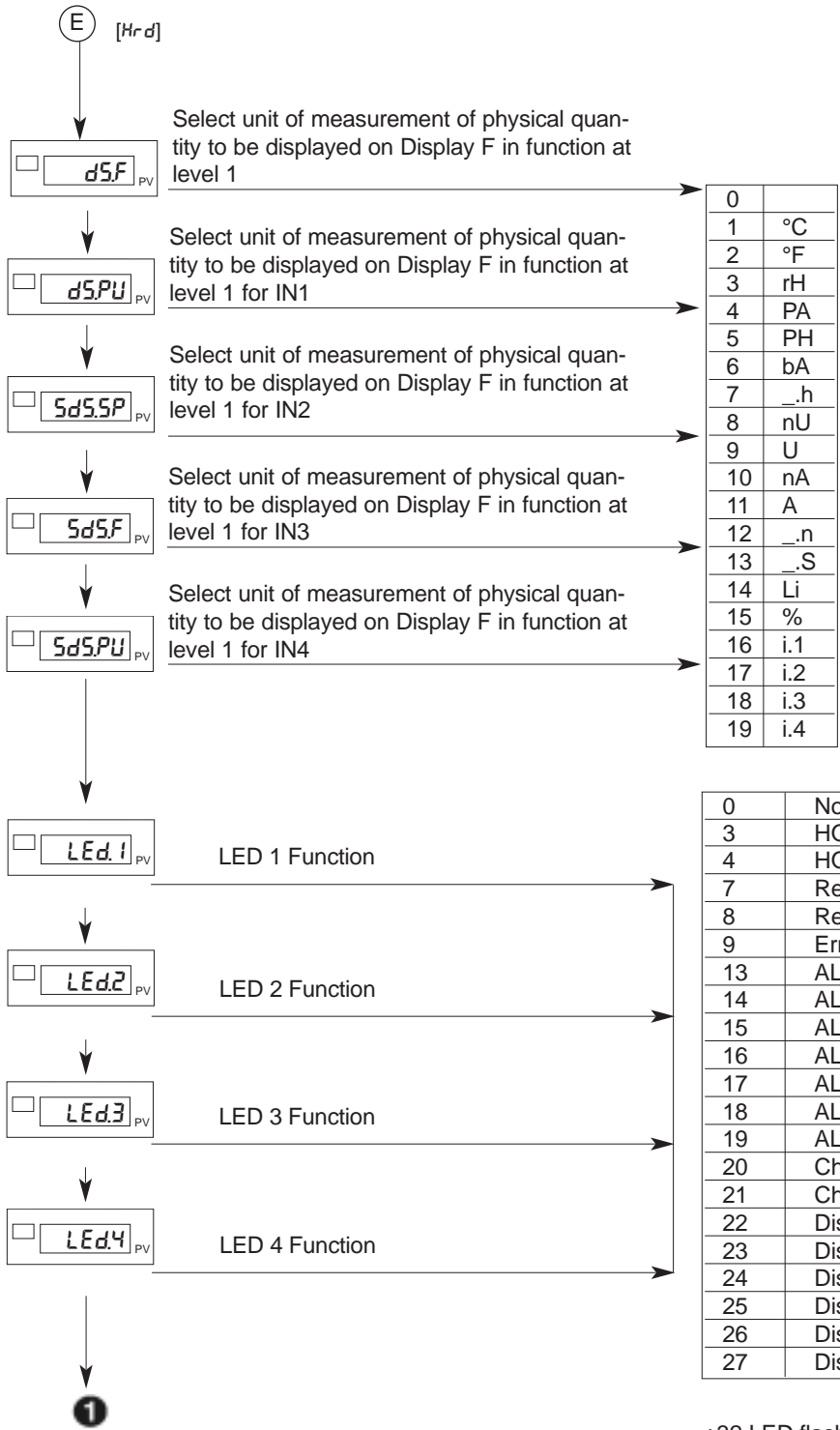

+32 LED flashes if on
 +64 LED state reversed

Lin Input Linearization

This menu lets you run custom linearization.

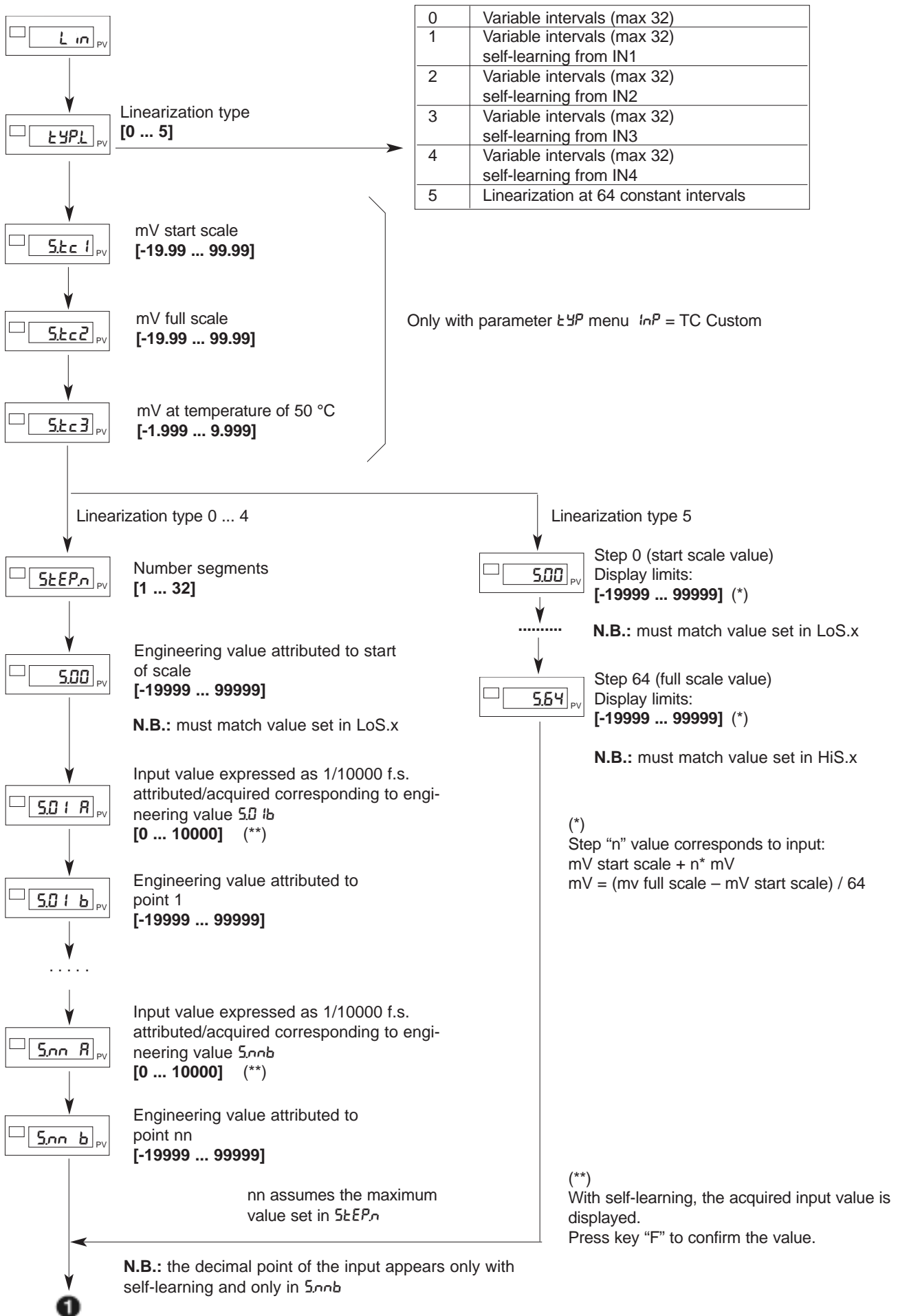

U.CAL User Calibration

This menu lets you run user calibration

	Function
0	-
1	Input IN1 *
2	Input IN2 *
3	Input IN3 *
4	Input IN4 *
7	CRt - retransmission output trimming
8	IN1 potentiometer input - manual setting of calibration values.

Note.: only for model with a single input: model 2400-0-...

Note:
calibration 4-20mA **NOT** allowed
(calibrate with 0-20mA input)
(from version V1.44)

+32 Reset factory calibration of selected input
(* Calibration takes place according to the type of input selected in configuration)

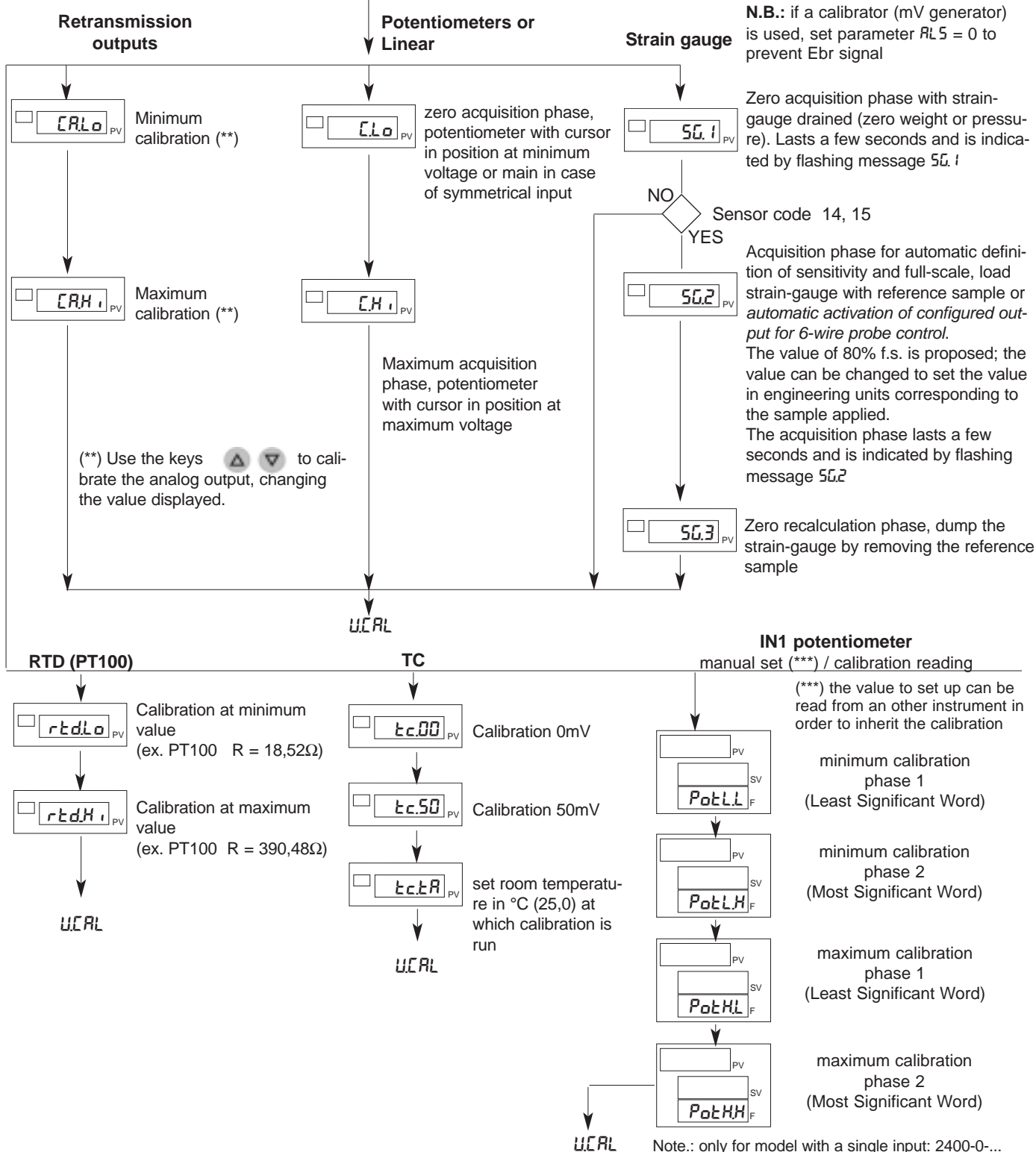

HOLD Function

The input value and alarms are frozen while the logic input is closed. With logic input closed, a reset turns OFF both the relay outputs and the alarms latch.

FLASH function

The input value is sampled, the setpoints are “frozen”, when the logic input switches on the input value is “frozen” and the setpoints are updated based on the last acquired value.

Alarms

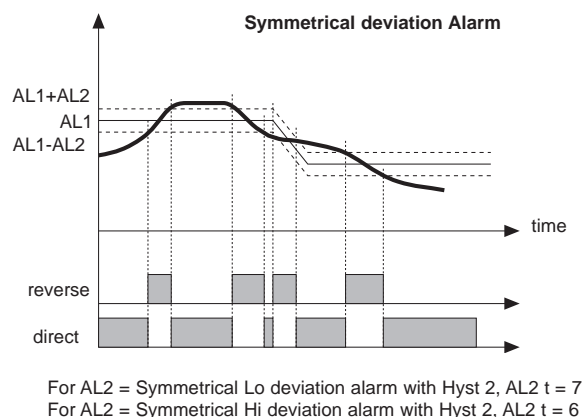
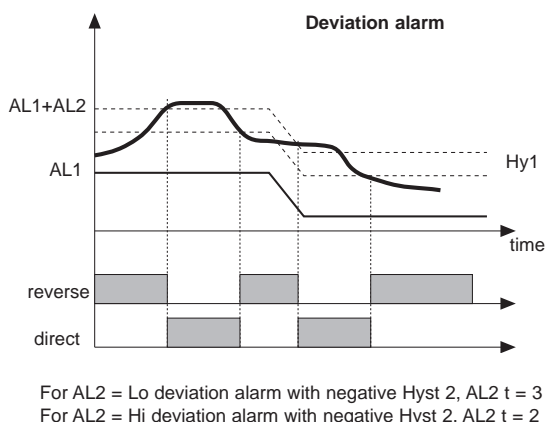
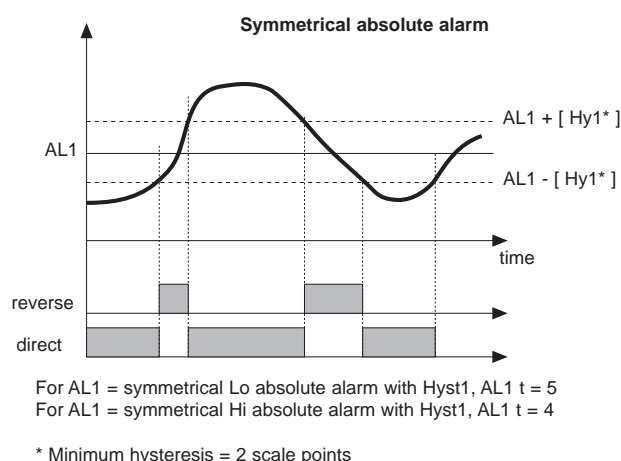
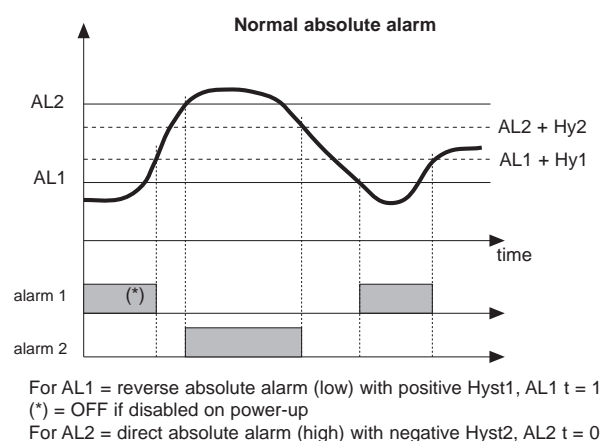

N.B.: For deviation alarms (At.n = deviation) with different reference quantities (Ar.n), which are set with different decimal points, the switch setpoint always refers to scale points without considering decimal point.
 ex.: if Ar.n = 0 (referred to IN1) and At.n = 6 (deviation referred to IN3) and IN1 with dP = 1, IN3 with dP = 2 AL1 = 200.0 IN3 = 10.00 dS.SP = 1, the alarm setpoint is 300.0

Software ON/OFF switching function

How to switch the unit OFF: hold down the “F” and “Raise” keys simultaneously for 5 seconds to deactivate the unit, which will go to the OFF state while keeping the line supply connected and keeping the process value displayed, keeping the “OFF” message displayed.

All outputs (alarms and controls) are OFF (logic level 0, relays de-energized) and all unit functions are disabled except the switch-on function and digital communication.

How to switch the unit ON: hold down the “F” key for 5 seconds and the unit will switch OFF to ON. If there is a power failure during the OFF state, the unit will remain in OFF state at the next power-up (ON/OFF state is memorized).

The function is normally enabled, but can be disabled by setting the parameter Prot = Prot +16. This function can be assigned to a digital input (d.i.G), not é subject to the disabilitazione from parameter “Prot” and excludes deactivation from the keyboard.

String assigned to an alarm

Each enabled alarm can be assigned an alphanumeric string composed of 5 characters, to be displayed on the PV in level 1.

The string of alarm n (with n from 1 to 10) is enabled by means of parameter At.n = +512 (to display the string when the alarm trips) or At.n = +1024 (to display the string when the alarm limit is exceeded in case of alarm with time delay).

The string is composed of parameters SdA.n, Sdb.n, SdC.n, Sdd.n and SdE.n, which define characters A, B, C, D and E of the PV display.

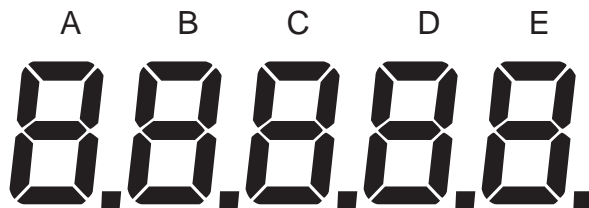

The 8 parameter set bits identify the 7 display segments and the decimal point; they are shown below in decimal values to be added, corresponding to the segments to be switched on.

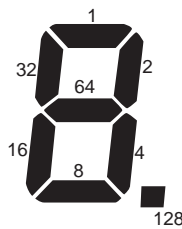

Example: to compose character "3" you have to set the parameter corresponding to the value $1+2+4+8+64 = 79$

The table with the settings corresponding to the most-used characters appears below.

Character to be displayed	Parameter setting	Character to be displayed	Parameter setting	Character to be displayed	Parameter setting
0	63	a	95	i	4
1	6	A	119	l	6
2	91	b	124	L	56
3	79	c	88	M	55
4	102	C	57	n	84
5	109	d	94	o	92
6	125	e	123	O	63
7	7	E	121	P	115
8	125	F	113	r	115
9	111	G	61	S	109
-	128	h	116	t	120
		H	118	U	62

In case of simultaneous strings on the PV display, the string corresponding to the lower alarm number has priority.

5 • TECHNICAL SPECIFICATIONS



This section contains a list of the Technical Specifications for the instrument 2400.

Display	1 x 5 red/green bicolor digits, height 13mm 1 x 2 red digits, height 7mm 14 x red led
Keys	6 mechanical keys (Peak, Cal/Rst, *, INC, DEC, F)
Accuracy	0.1% f.s. ± 1 at 25°C room temperature
Thermal drift	< 150ppm/°C on f.s. for current/voltage and strain-gauge inputs
IN1, IN2 main input/s	Strain-gauge: 350 Ω , sensibility 1,5...4mV/V, with probe power supply 5/10Vdc $\pm 5\%$ Potentiometer: $\geq 100\Omega$, Ri > 10M Ω @ 2,5Vdc Linear DC: $\pm 60\text{mV}$, $\pm 100\text{mV}$, $\pm 1\text{V}$, $\pm 5\text{V}$, $\pm 10\text{V}$, Ri > 10M Ω 0/4...20mA, Ri = 50 Ω TC, RTD Sampling time 2msec
TC type (Thermocouples) (ITS90)	J, K, R, S, T (IEC 584-1, CEI EN 60584-1,60584-2) a 64 segment custom linearization can be inserted
Cold junction error	0,1°C / °C
RTD type (Temperature resistance) (ITS90)	Pt100 (DIN 43760), 20 Ω
Max. line resistance for RTD	
Safety	Detection of short-circuit or opening of probes, no probe power; LBA alarm
IN3, IN4 auxiliary inputs	Potentiometer: 1...10K Ω , @ 10Vdc Linear DC: 10V, Ri > 2M Ω 0/4...20mA, Ri = 50 Ω Sampling time 10ms
Linear scale ranges	-19999...99999, with configurable decimal point position
Type of relay contact	NO (NC) 5A, 250V/30Vdc $\cos\phi = 1$
OUT 1, OUT 2, OUT 3, OUT 4 outputs	
Logic output	24Vdc, > 18V at 20mA, source / sink type
OUT 1, OUT 2, OUT 3, OUT 4 outputs	Ru = 390 Ω
Relay / logic outputs with MD8 OUT3, ..., OUT 10	The outputs are assigned to the state of alarms AL3,...,AL10 Refresh every 2ms.
Digital inputs	Isolation 1500V, sampling time 60ms
DI1, DI2	24Vdc, 5mA (PNP) or by voltage-free contact (NPN) max 5mA select PNP/NPN via configuration parameter
OUT W analog retransmission	Continuous, resolution improved by 0,03%, isolation 1500V refresh every 2msec in sync with sampling of variables IN1 and IN2 0/2...10V, $\pm 10\text{V}$ max 25mA, short-circuit protection 0/4...20mA, max load 500 Ω
Max power limit	-100.0 ... 100.0%
Fault power setting	Maintains PV value display
Configurable alarms	Up to 3 alarm functions assignable to an output and configurable of type: maximum, minimum, symmetrical, absolute, relative, LBA for AL1, AL2 calculation every 2ms in sync with sampling of variables IN1 and IN2, For AL3, ..., AL 10 calculation every 2...4 ms, depending on number of alarms
Alarm masking	Exclusion during warm up, memory, reset from faceplate and/or contact
Probe power supply	5Vdc, 10Vdc, for strain-gauge probes, max 200mA 1,2Vdc for potentiometers $\geq 100\Omega$
Transmitter power supply	24Vdc $\pm 5\%$, max 100mA
Serial interface	RS485 isolation 1500V
Baudrate	1200, 2400, 4800, 9600, 19200, 38400, 57600, 115200 bit/s
Protocol	MODBUS RTU
Power supply (switching type)	(standard) 100...240Vac/dc $\pm 10\%$ (optional) 20...27Vac/dc $\pm 10\%$ 50/60Hz, max 20VA protection via internal fuse, not replaceable by operator
Faceplate protection	IP54 (optional IP65)
Working / Storage temperature range	0...50°C/-20...70°C
Relative humidity	20...85% Ur non-condensing
Environmental working conditions	For indoor use, altitudes up to 2000m
Installation	Panel, removable faceplate
Installation specifications	Installation category II, pollution level 2, double isolation
Weight	450g

6 • MAINTENANCE



This section gives the information and the necessary warnings for routine maintenance of the instrument 2400 and contains a Troubleshooting Guide which should be read before seeking help from the Gefran Customer Service Assistance, in the event of instrument malfunction.

If installed and configured correctly according to the instructions and the recommendations provided in Sections 2 and 4 of these Instructions for use, the instrument 2400 will work normally without any need for maintenance, apart from the usual operations of cleaning the faceplate, and if necessary the internal parts of the instrument.



To gain access to the inside of the instrument (for example for cleaning or to check the jumpers) just undo the screw at the bottom of the faceplate and take out the instrument without having to disconnect the cables.

Make sure that the power is turned off upstream of the instrument however.

Remember that the instrument 2400 is not equipped with an ON/OFF switch.



Cleaning

To clean the faceplate and the case use only a cloth dampened in water or ethyl alcohol.

Do not use hydrocarbon-based solvents (trichlorethylene, petrol, etc.).

Do not use compressed air to remove dust from the electronic circuit boards, if necessary use a clean brush with soft bristles.



Repairs

Repairs to the Controller must only be carried out by qualified technicians, properly trained and authorized by Gefran.

Any attempts at repair or modification of the Controller hardware characteristics by unauthorized personnel will invalidate the warranty.

Checking the jumpers

CPU Board

The component side of the CPU board contains the jumper S9 which enables (if on) access to the instrument menus.

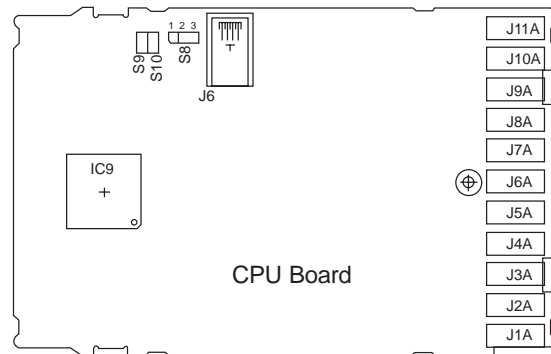

POWER Board

Jumpers J1, J2, J3, J4 for selection of contact type no/nc for the relay outputs are present on the component side of the POWER board.

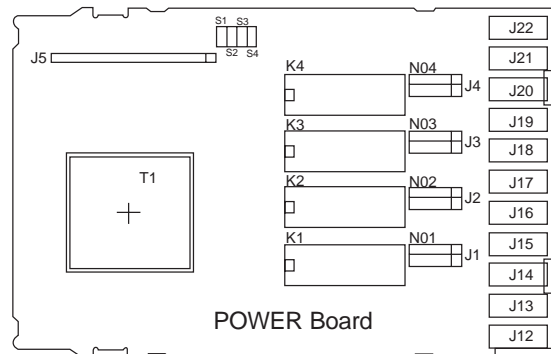

The controller contains components which are sensitive to electrostatic discharge, so the relevant precautions must be taken when handling the electronic circuit boards contained in it, in order to avoid permanent damage to components themselves.

Troubleshooting Guide

Symptom	Cause and Recommended remedy
The Controller display and Led do not come on	Instrument power supply problem. Check that power is being supplied to terminals 10-11. make sure the power supply corresponds with the one stated in the order code: 2400 - x - x - x - x - 1 = 100..240Vac/dc 2400 - x - x - x - x - 0 = 20..27Vac/dc
The characters shown on the display are incomplete or illegible	Possible fault with one of the display segments. Check that all the segments are working properly by switching the instrument off and then on again. When it is switched on again a self-diagnostic test is performed that checks intermittent start up of all the segments (displays the value BBBBB). If one or more segments do not light up contact your Gefran dealer.
When pressing down F none of the configuration menus can be accessed	If the problem occurs in the initial installation phase, it probably means that the instrument hardware configuration does not give the option of editing the preset parameters, apart from the setpoint value or the alarm point, at level 1 to display. (For modified of parameters jumper S9 on the CPU board).
When pressing down F not all of the parameters and/or configuration menus can be accessed	Access to some menus and/or parameters is controlled by a password (PR5) and by a protection code (Pr0) which disables the modalità configuration mode. To set the password and the protection code correctly refer to Section 4 "Configuration/Programming".
Instead of the process variable the PV display shows one of the following: L0 - H1 - Sbr - Err - Ebr Ebr.L0 - Err.Ed	In the first four cases it means that an input error has been found (for details refer to Section 3 - Functions). Err , means that in case of Pt100 probe, the input is in short circuit. In case of TC in short circuit, the PV display shows room temperature instead of the process variable. In case of input 4...20mA, it indicates that the transmitter is broken or not powered. Ebr means strain-gauge probe broken or not powered. Ebr.L0 no power to probe Err.Ed third wire of PT100 probe broken or not connected

7 • TECHNICAL/COMMERCIAL INFORMATION



This section contains information regarding the instrument order codes and the main accessories available.

As stated in the Preliminary Warnings of these Instructions for Use, correct interpretation of the Controller order code allows the hardware configuration for the controller to be identified immediately and so it is essential to quote the order code each time the Gefran Customer Care Service is contacted for assistance with any problems.

Order code – Indicator / Interceptor 2400

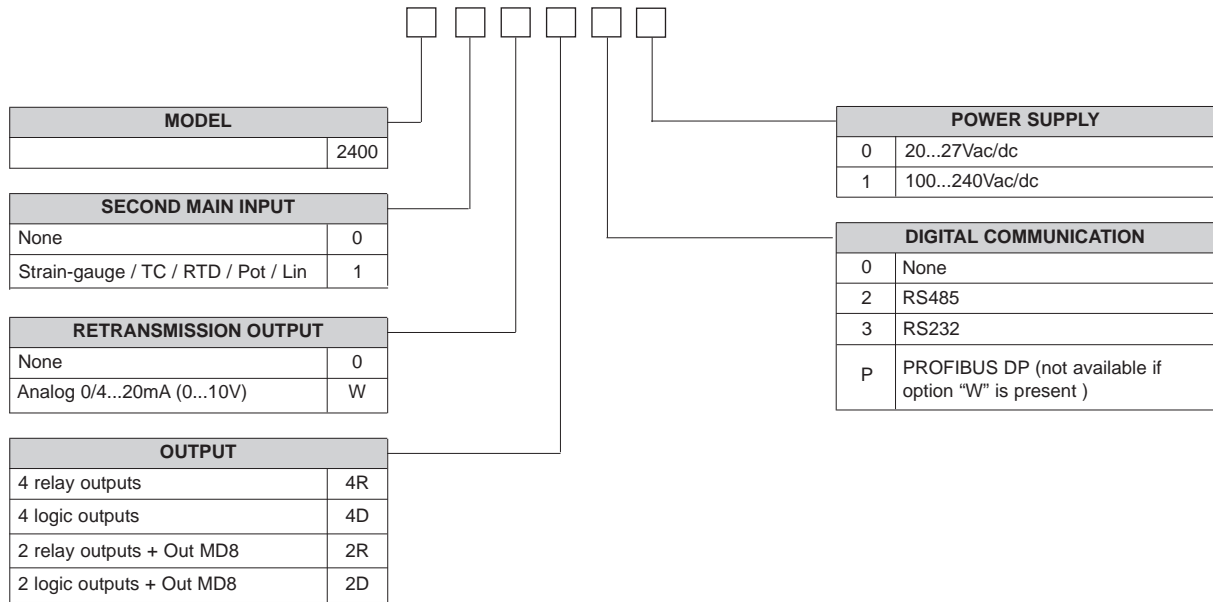

The MD8 expansion must be version MD8-2, specific for the 2400



For information on the availability of codes please contact your Gefran dealer.

ACCESSORIES

• RS232 / TTL interface for GEFRAN instrument configuration



N.B. RS232 interface for PC configuration is supplied with the WINSTRUM programming software. Make connection with instrument powered but with inputs and outputs disconnected.

• ORDER CODE

WSK-0-0-0

Cable interface + CD Winstrum

APPENDIX

Display	Default	CONF	Description
Menu MAIN			
<i>PU / SU / F</i>	-		
<i>In.1</i>	-		Input IN 1 main
<i>In.2</i>	-		Input IN 2 main
<i>In.3</i>	-		Input IN3 auxiliary
<i>In.4</i>	-		Input IN4 auxiliary
<i>FinA</i>	-		Result math function A
<i>FinB</i>	-		Result math function b
<i>AL.1</i>	100		Alarm 1 setpoint
<i>AL.2</i>	200		Alarm 2 setpoint
<i>AL.3</i>	300		Alarm 3 setpoint
<i>AL.4</i>	400		Alarm 4 setpoint
<i>AL.5</i>	500		Alarm 5 setpoint
<i>AL.6</i>	600		Alarm 6 setpoint
<i>AL.7</i>	700		Alarm 7 setpoint
<i>AL.8</i>	800		Alarm 8 setpoint
<i>AL.9</i>	900		Alarm 9 setpoint
<i>AL.10</i>	1000		Alarm 10 setpoint
Menu InF			
<i>UPd</i>	-		Software release
<i>Cod</i>	-		Instrument code
<i>Err.1</i>	-		Error code for IN1
<i>Err.2</i>	-		Error code for IN2
<i>Err.3</i>	-		Error code for IN3
<i>Err.4</i>	-		Error code for IN4
<i>Err.5</i>	-		Error code for Fin. A
<i>Err.6</i>	-		Error code for Fin. b
<i>dPS.5</i>	-		Decimal point position Fin. A
<i>dPS.6</i>	-		Decimal point position Fin. b
<i>Lo.5.5</i>	-		MIN scale limit Fin. A (read only)
<i>Lo.5.6</i>	-		MIN scale limit Fin. b (read only)
<i>Hi.5.5</i>	-		MAX scale limit Fin. A (read only)
<i>Hi.5.6</i>	-		MAX scale limit Fin. b (read only)
<i>UPdF</i>	-		Fieldbus software version
<i>CodF</i>	-		Fieldbus instrument code (read only)
<i>bRv.F</i>	-		Set fieldbus baudrate (read only)
Menu SEr			
<i>Cod</i>	1		Instrument code
<i>bRv</i>	4		Serial communication baudrate
<i>PRr</i>	0		Serial communication parity
Menu InP1			
<i>tYP.1</i>	14		Type of probe or signal for input IN1
<i>FLt.1</i>	0.1		Digital filter input IN1
<i>dPS.1</i>	0		Decimal point position for IN1
<i>Lo.5.1</i>	0		Min. scale limit input IN1
<i>Hi.5.1</i>	3500		Max. scale limit input IN1
<i>OF5.1</i>	0.0		Offset input IN1
<i>SGOF.1</i>	0.000		Offset input IN1 calibrated 40mV
<i>SGSE.1</i>	4.000		Sensitivity input IN1 calibrated 40mV
Menu InP2			
<i>tYP.2</i>	0		Type of probe or signal for input IN2
<i>FLt.2</i>	0.1		Digital filter input IN2
<i>dPS.2</i>	0		Decimal point position for IN2
<i>Lo.5.2</i>	0		Min. scale limit input IN2
<i>Hi.5.2</i>	1000		Max. scale limit input IN2
<i>OF5.2</i>	0		Offset input IN2
<i>SGOF.2</i>	0.000		Offset input IN2 calibrated 40mV
<i>SGSE.2</i>	4.000		Sensitivity input IN2 calibrated 40mV
Menu InP3			
<i>tYP.3</i>	1		Type of probe or signal for input IN3
<i>FLt.3</i>	0.1		Digital filter input IN3
<i>dPS.3</i>	0		Decimal point position for IN3
<i>Lo.5.3</i>	0		Min. scale limit input IN3
<i>Hi.5.3</i>	1000		Max. scale limit input IN3
<i>OF5.3</i>	0		Offset input IN3

Display	Default	CONF	Description
Menu <i>InP4</i>			
<i>EP4</i>	0		Type of probe or signal for input IN4
<i>FL4</i>	0.1		Digital filter input IN4
<i>dP5.4</i>	0		Decimal point position for IN4
<i>Lo5.4</i>	0		Min. scale limit input IN4
<i>H 15.4</i>	1000		Max. scale limit input IN4
<i>OF5.4</i>	0		Offset input IN4
Menu <i>ALL</i>			
<i>Ar.1</i>	0		Alarm reference 1
<i>Al.1</i>	0		Type alarm 1
<i>HY.1</i>	-1		Alarm hysteresis 1
<i>rR.1</i>	0		Activation time alarm 1
<i>bt.1</i>	0		Time base for activation time alarm 1
<i>SdR.1</i>	0		Character A alarm string 1
<i>Sdb.1</i>	0		Character B alarm string 1
<i>SdC.1</i>	0		Character C alarm string 1
<i>Sdd.1</i>	0		Character D alarm string 1
<i>SdE.1</i>	0		Character E alarm string 1
<i>Ar.2</i>	0		Alarm reference 2
<i>Al.2</i>	0		Type alarm 2
<i>HY.2</i>	-1		Alarm hysteresis 2
<i>rR.2</i>	0		Activation time alarm 2
<i>bt.2</i>	0		Time base for activation time alarm 2
<i>SdR.2</i>	0		Character A alarm string 2
<i>Sdb.2</i>	0		Character B alarm string 2
<i>SdC.2</i>	0		Character C alarm string 2
<i>Sdd.2</i>	0		Character D alarm string 2
<i>SdE.2</i>	0		Character E alarm string 2
<i>Ar.3</i>	0		Alarm reference 3
<i>Al.3</i>	0		Type alarm 3
<i>HY.3</i>	-1		Alarm hysteresis 3
<i>rR.3</i>	0		Activation time alarm 3
<i>bt.3</i>	0		Time base for activation time alarm 3
<i>SdR.3</i>	0		Character A alarm string 3
<i>Sdb.3</i>	0		Character B alarm string 3
<i>SdC.3</i>	0		Character C alarm string 3
<i>Sdd.3</i>	0		Character D alarm string 3
<i>SdE.3</i>	0		Character E alarm string 3
<i>Ar.4</i>	0		Alarm reference 4
<i>Al.4</i>	0		Type alarm 4
<i>HY.4</i>	-1		Alarm hysteresis 4
<i>rR.4</i>	0		Activation time alarm 4
<i>bt.4</i>	0		Time base for activation time alarm 4
<i>SdR.4</i>	0		Character A alarm string 4
<i>Sdb.4</i>	0		Character B alarm string 4
<i>SdC.4</i>	0		Character C alarm string 4
<i>Sdd.4</i>	0		Character D alarm string 4
<i>SdE.4</i>	0		Character E alarm string 4
<i>Ar.5</i>	0		Alarm reference 5
<i>Al.5</i>	0		Type alarm 5
<i>HY.5</i>	-1		Alarm hysteresis 5
<i>rR.5</i>	0		Activation time alarm 5
<i>bt.5</i>	0		Time base for activation time alarm 5
<i>SdR.5</i>	0		Character A alarm string 5
<i>Sdb.5</i>	0		Character B alarm string 5
<i>SdC.5</i>	0		Character C alarm string 5
<i>Sdd.5</i>	0		Character D alarm string 5
<i>SdE.5</i>	0		Character E alarm string 5
<i>Ar.6</i>	0		Alarm reference 6
<i>Al.6</i>	0		Type alarm 6
<i>HY.6</i>	-1		Alarm hysteresis 6
<i>rR.6</i>	0		Activation time alarm 6
<i>bt.6</i>	0		Time base for activation time alarm 6
<i>SdR.6</i>	0		Character A alarm string 6
<i>Sdb.6</i>	0		Character B alarm string 6
<i>SdC.6</i>	0		Character C alarm string 6
<i>Sdd.6</i>	0		Character D alarm string 6

Display	Default	CONF	Description
<i>SdE.6</i>	0		Character E alarm string 6
<i>Rr.7</i>	0		Alarm reference 7
<i>Rt.7</i>	0		Type alarm 7
<i>HY.7</i>	-1		Alarm hysteresis 7
<i>rR.7</i>	0		Activation time alarm 7
<i>bt.7</i>	0		Time base for activation time alarm 7
<i>SdR.7</i>	0		Character A alarm string 7
<i>Sdb.7</i>	0		Character B alarm string 7
<i>SdC.7</i>	0		Character C alarm string 7
<i>Sdd.7</i>	0		Character D alarm string 7
<i>SdE.7</i>	0		Character E alarm string 7
<i>Rr.8</i>	0		Alarm reference 8
<i>Rt.8</i>	0		Type alarm 8
<i>HY.8</i>	-1		Alarm hysteresis 8
<i>rR.8</i>	0		Activation time alarm 8
<i>bt.8</i>	0		Time base for activation time alarm 8
<i>SdR.8</i>	0		Character A alarm string 8
<i>Sdb.8</i>	0		Character B alarm string 8
<i>SdC.8</i>	0		Character C alarm string 8
<i>Sdd.8</i>	0		Character D alarm string 8
<i>SdE.8</i>	0		Character E alarm string 8
<i>Rr.9</i>	0		Alarm reference 9
<i>Rt.9</i>	0		Type alarm 9
<i>HY.9</i>	-1		Alarm hysteresis 9
<i>rR.9</i>	0		Activation time alarm 9
<i>bt.9</i>	0		Time base for activation time alarm 9
<i>SdR.9</i>	0		Character A alarm string 9
<i>Sdb.9</i>	0		Character B alarm string 9
<i>SdC.9</i>	0		Character C alarm string 9
<i>Sdd.9</i>	0		Character D alarm string 9
<i>SdE.9</i>	0		Character E alarm string 9
<i>Rr.10</i>	0		Alarm reference 10
<i>Rt.10</i>	0		Type alarm 10
<i>HY.10</i>	-1		Alarm hysteresis 10
<i>rR.10</i>	0		Activation time alarm 10
<i>bt.10</i>	0		Time base for activation time alarm 10
<i>SdR.10</i>	0		Character A alarm string 10
<i>Sdb.10</i>	0		Character B alarm string 10
<i>SdC.10</i>	0		Character C alarm string 10
<i>Sdd.10</i>	0		Character D alarm string 10
<i>SdE.10</i>	0		Character E alarm string 10
<i>LoAL</i>	0		Lower limit alarm setpoint
<i>H IRL</i>	3500		Upper limit alarm setpoint
<i>rEL</i>	0		Alarm state in Fault Action condition
Menu Out			
<i>rL.1</i>	1		Output reference OUT1
<i>rL.2</i>	2		Output reference OUT2
<i>rL.3</i>	3		Output reference OUT3
<i>rL.4</i>	18		Output reference OUT4
<i>tYPRn</i>	0		Type of retransmission output W
<i>r IFRn</i>	0		Output reference W
<i>LoRn</i>	0		Minimum scale output W
<i>H I Rn</i>	3500		Maximum scale output W
<i>RLS</i>	2		Select probe power supply
Menu PRS			
<i>PRS</i>	0		Pass-word
<i>Pro</i>	0		Protection code
Menu Hrd			
<i>hd.1</i>	8		Enable multiset/type process/line freq.
<i>Func.R</i>	0		Math function A
<i>In 1R</i>	0		First operand of <i>Func.R</i>
<i>In 2R</i>	0		Second operand of <i>Func.R</i>
<i>OPER.R</i>	0		Operator of <i>Func.R</i>
<i>C 1R</i>	0		Coefficient <i>C 1R</i>
<i>C 2R</i>	0		Coefficient <i>C 2R</i>
<i>C 3R</i>	0		Coefficient <i>C 3R</i>

Display	Default	CONF	Description
$C4A$	0		Coefficient $C4A$
$C5A$	0		Coefficient $C5A$
$F_{unc.b}$	0		Math function b
$In1b$	0		First operand of $F_{unc.b}$
$In2b$	0		Second operand of $F_{unc.b}$
$OP_{Er.b}$	0		Operator of $F_{unc.b}$
$C1b$	0		Coefficient $C1b$
$C2b$	0		Coefficient $C2b$
$C3b$	0		Coefficient $C3b$
$C4b$	0		Coefficient $C4b$
$C5b$	0		Coefficient $C5b$
AL_n	4		Number of alarms enabled
$but.1$	8		Function key (Peak)
$but.2$	15		Function key (Cal/Rst)
$but.3$	0		Function key (*)
$dIG.1$	0		Digital function input DI1
$dIG.2$	0		Digital function input DI2
FLd	0.5		Digital filter on PV display
dSP	1		Select variable displayed on SV display
dSF	0		Select variable displayed on F display
$dSPU$	16		Select unit of measurement on display F for In.1
dSP	17		Select unit of measurement on display F for In.2
dSF	18		Select unit of measurement on display F for In.3
$dSPU$	19		Select unit of measurement on display F for In.4
$LEd.1$	22		Function Led 1
$LEd.2$	20		Function Led 2
$LEd.3$	7		Function Led 3
$LEd.4$	8		Function Led 4

Display	Default	CONF	Description
Menu L <i>n</i>			
LYPL	0		Type linearization
SEPN	32		Number segments
S00 (5.00)	0		Segment 0 low scale linearized value (Step 0)
S01 A (5.01)	313		Segment 1 input value [1/10.000] f.s. (Step 1)
S01 b (5.02)	31		Segment 1 linearized value (Step 2)
S02 A (5.03)	625		Segment 2 input value [1/10.000] f.s. (Step 3)
S02 b (5.04)	63		Segment 2 linearized value (Step 4)
S03 A (5.05)	938		Segment 3 input value [1/10.000] f.s. (Step 5)
S03 b (5.06)	94		Segment 3 linearized value (Step 6)
S04 A (5.07)	1250		Segment 4 input value [1/10.000] f.s. (Step 7)
S04 b (5.08)	125		Segment 4 linearized value (Step 8)
S05 A (5.09)	1563		Segment 5 input value [1/10.000] f.s. (Step 9)
S05 b (5.10)	156		Segment 5 linearized value (Step 10)
S06 A (5.11)	1875		Segment 6 input value [1/10.000] f.s. (Step 11)
S06 b (5.12)	188		Segment 6 linearized value (Step 12)
S07 A (5.13)	2188		Segment 7 input value [1/10.000] f.s. (Step 13)
S07 b (5.14)	219		Segment 7 linearized value (Step 14)
S08 A (5.15)	2500		Segment 8 input value [1/10.000] f.s. (Step 15)
S08 b (5.16)	250		Segment 8 linearized value (Step 16)
S09 A (5.17)	2813		Segment 9 input value [1/10.000] f.s. (Step 17)
S09 b (5.18)	281		Segment 9 linearized value (Step 18)
S10 A (5.19)	3125		Segment 10 input value [1/10.000] f.s. (Step 19)
S10 b (5.20)	313		Segment 10 linearized value (Step 20)
S11 A (5.21)	3438		Segment 11 input value [1/10.000] f.s. (Step 21)
S11 b (5.22)	344		Segment 11 linearized value (Step 22)
S12 A (5.23)	3750		Segment 12 input value [1/10.000] f.s. (Step 23)
S12 b (5.24)	375		Segment 12 linearized value (Step 24)
S13 A (5.25)	4063		Segment 13 input value [1/10.000] f.s. (Step 25)
S13 b (5.26)	406		Segment 13 linearized value (Step 26)
S14 A (5.27)	4375		Segment 14 input value [1/10.000] f.s. (Step 27)
S14 b (5.28)	438		Segment 14 linearized value (Step 28)
S15 A (5.29)	4688		Segment 15 input value [1/10.000] f.s. (Step 29)
S15 b (5.30)	469		Segment 15 linearized value (Step 30)
S16 A (5.31)	5000		Segment 16 input value [1/10.000] f.s. (Step 31)
S16 b (5.32)	500		Segment 16 linearized value (Step 32)
S17 A (5.33)	5313		Segment 17 input value [1/10.000] f.s. (Step 33)
S17 b (5.34)	531		Segment 17 linearized value (Step 34)
S18 A (5.35)	5625		Segment 18 input value [1/10.000] f.s. (Step 35)
S18 b (5.36)	563		Segment 18 linearized value (Step 36)
S19 A (5.37)	5938		Segment 19 input value [1/10.000] f.s. (Step 37)
S19 b (5.38)	594		Segment 19 linearized value (Step 38)
S20 A (5.39)	6250		Segment 20 input value [1/10.000] f.s. (Step 39)
S20 b (5.40)	625		Segment 20 linearized value (Step 40)
S21 A (5.41)	6563		Segment 21 input value [1/10.000] f.s. (Step 41)
S21 b (5.42)	656		Segment 21 linearized value (Step 42)
S22 A (5.43)	6875		Segment 22 input value [1/10.000] f.s. (Step 43)
S22 b (5.44)	688		Segment 22 linearized value (Step 44)
S23 A (5.45)	7188		Segment 23 input value [1/10.000] f.s. (Step 45)
S23 b (5.46)	719		Segment 23 linearized value (Step 46)
S24 A (5.47)	7500		Segment 24 input value [1/10.000] f.s. (Step 47)
S24 b (5.48)	750		Segment 24 linearized value (Step 48)
S25 A (5.49)	7813		Segment 25 input value [1/10.000] f.s. (Step 49)
S25 b (5.50)	781		Segment 25 linearized value (Step 50)
S26 A (5.51)	8125		Segment 26 input value [1/10.000] f.s. (Step 51)
S26 b (5.52)	813		Segment 26 linearized value (Step 52)
S27 A (5.53)	8438		Segment 27 input value [1/10.000] f.s. (Step 53)
S27 b (5.54)	844		Segment 27 linearized value (Step 54)
S28 A (5.55)	8750		Segment 28 input value [1/10.000] f.s. (Step 55)
S28 b (5.56)	875		Segment 28 linearized value (Step 56)
S29 A (5.57)	9063		Segment 29 input value [1/10.000] f.s. (Step 57)
S29 b (5.58)	906		Segment 29 linearized value (Step 58)
S30 A (5.59)	9375		Segment 30 input value [1/10.000] f.s. (Step 59)
S30 b (5.60)	938		Segment 30 linearized value (Step 60)
S31 A (5.61)	9688		Segment 31 input value [1/10.000] f.s. (Step 61)
S31 b (5.62)	969		Segment 31 linearized value (Step 62)
S32 A (5.63)	10000		Segment 32 input value [1/10.000] f.s. (Step 63)
S32 b (5.64)	1000		Segment 32 linearized value (Step 64)
SEc1	0.00		Step mV start scale - for custom Tc only
SEc2	0.00		Step mv full scale - for custom Tc only
SEc3	0.000		Step mV at 50°C - for custom Tc only

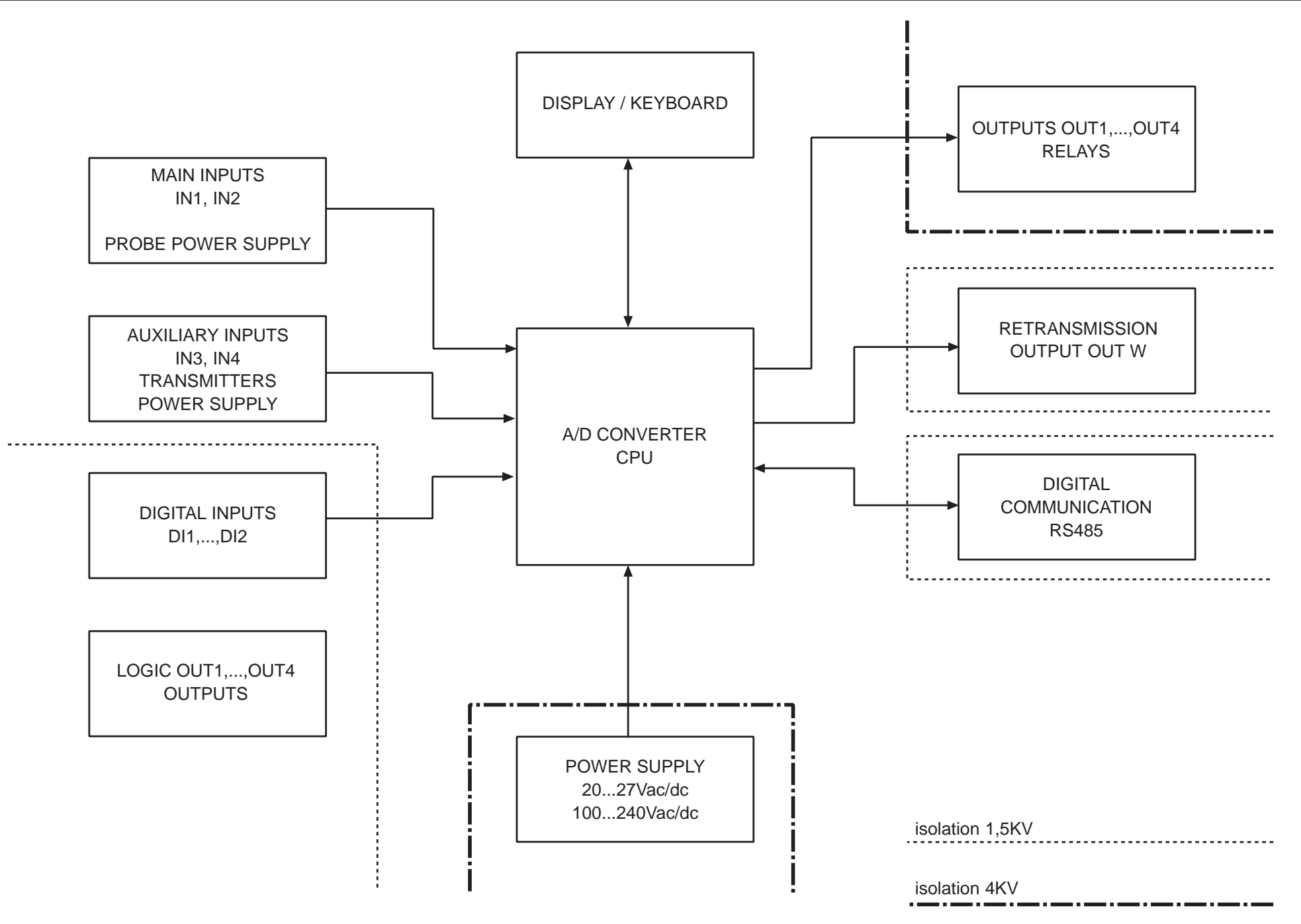

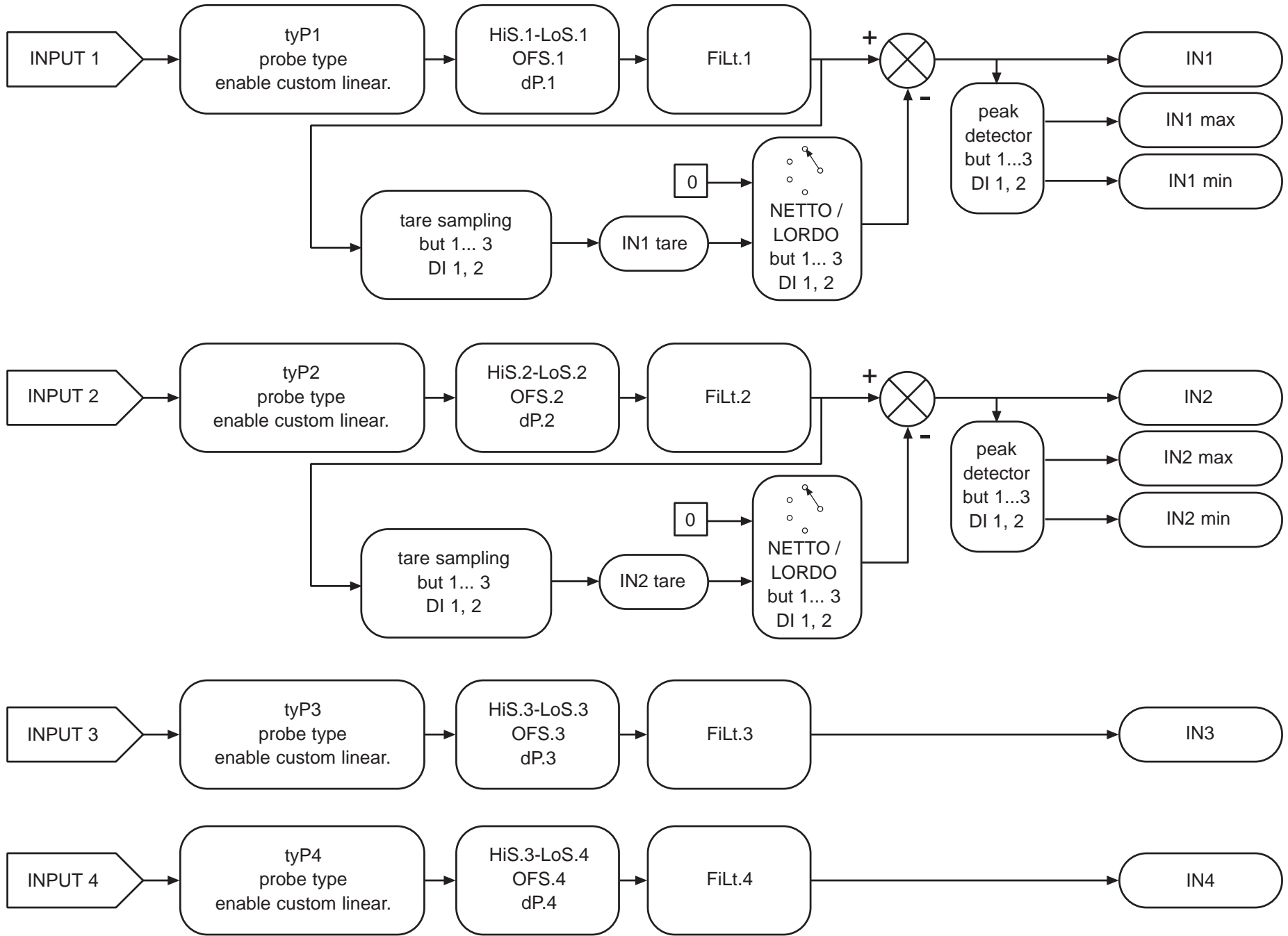

FUNCTIONAL DIAGRAM

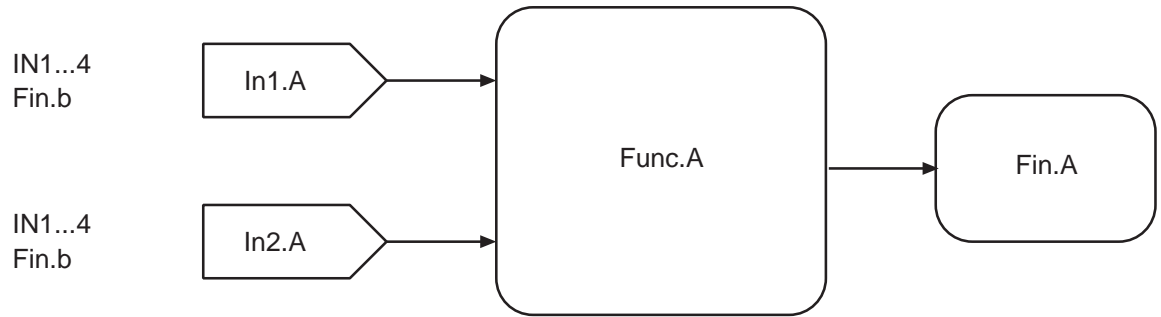

$$\text{Fin.A} = (((\text{C1.A} * \text{In1.A})^{\text{C2.A}} \text{OPER.A} ((\text{C3.A} * \text{In2.A})^{\text{C4.A}})) / \text{C5.A}$$

where OPER.A = +, -, *, /

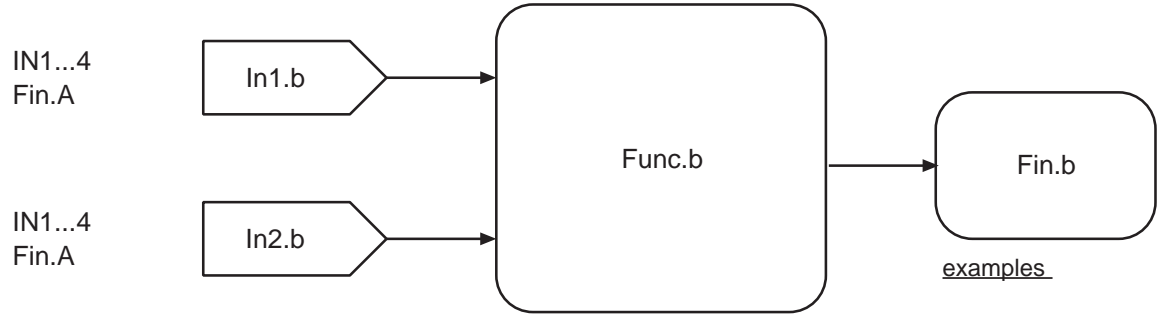

$$\text{Fin.b} = (((\text{C1.b} * \text{In1.b})^{\text{C2.b}} \text{OPER.b} ((\text{C3.b} * \text{In2.b})^{\text{C4.b}})) / \text{C5.b}$$

where OPER.b = +, -, *, /

examples

	<u>In.1</u>	<u>In.b</u>	<u>OPER</u>	<u>C1</u>	<u>C2</u>	<u>C3</u>	<u>C4</u>	<u>C5</u>
IN1+IN2	IN1	IN2	+	1	1	1	1	1
IN1-IN2	IN1	IN2	-	1	1	1	1	1
IN1/IN2	IN1	IN2	/	1	1	1	1	1
square root IN1	IN1	0	+	1	0.5	0	1	1
(IN1+IN2) / 2	IN1	IN2	+	1	1	1	1	2
IN3 * C1	IN1	0	+	C1	1	0	1	1

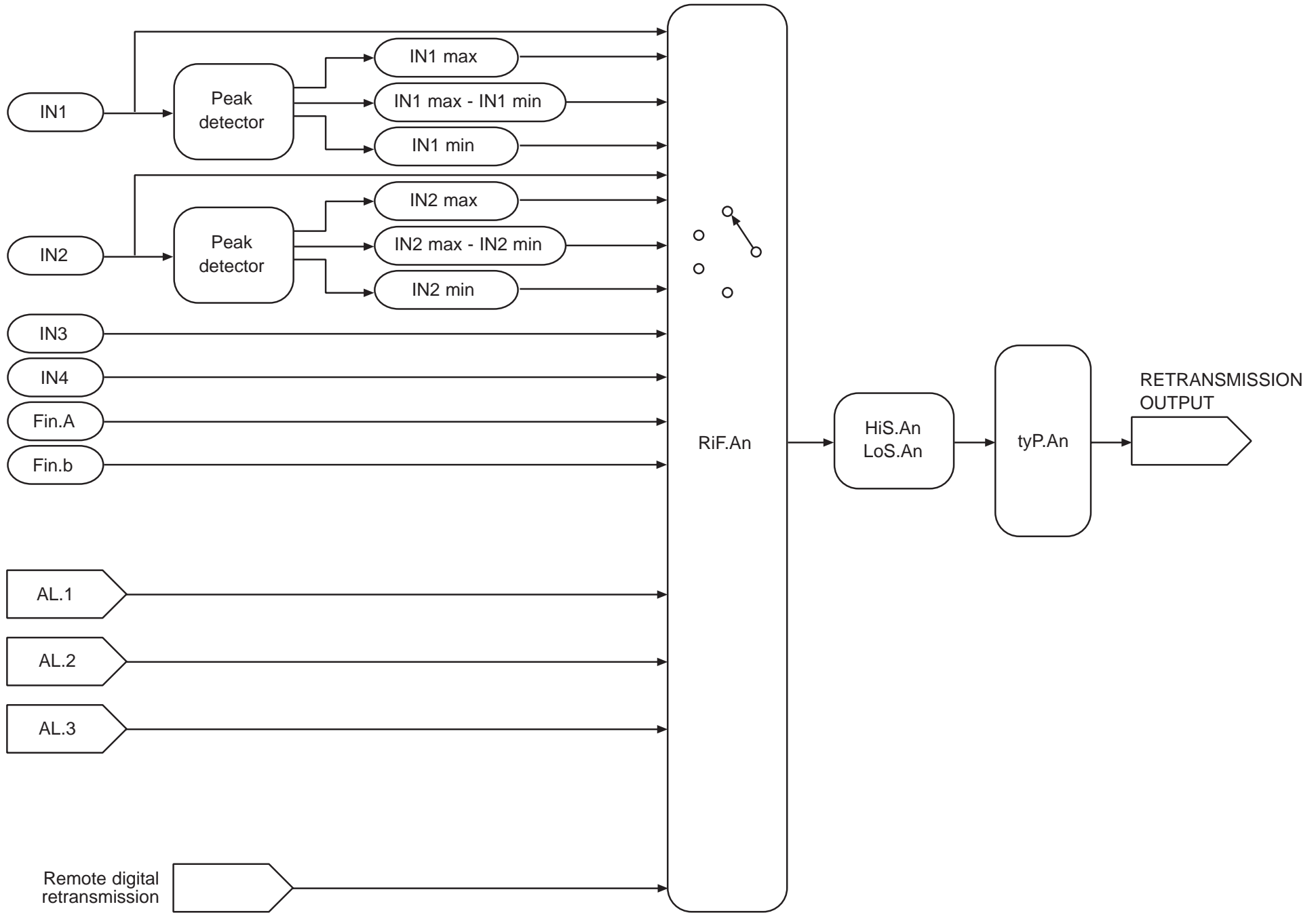

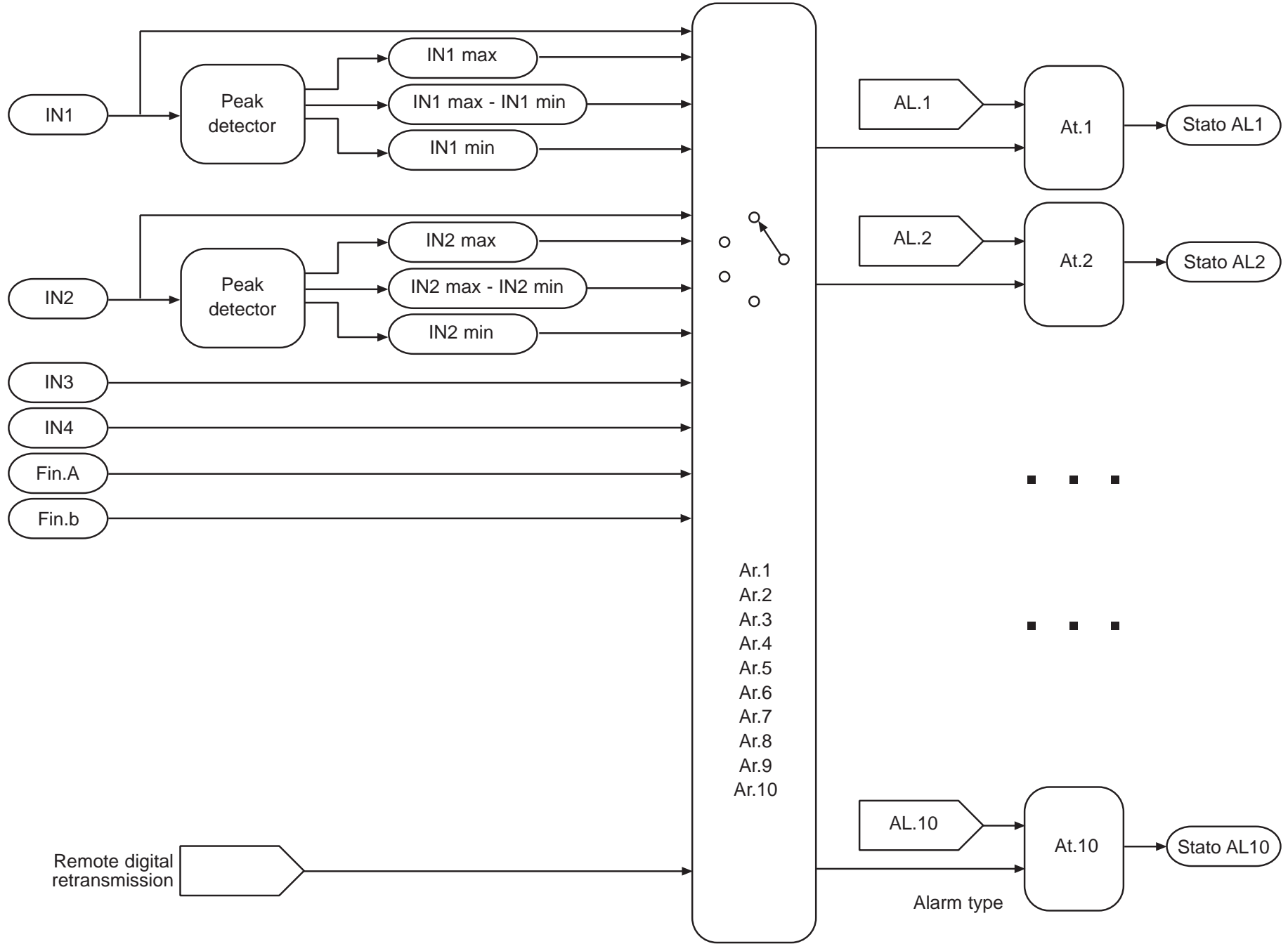

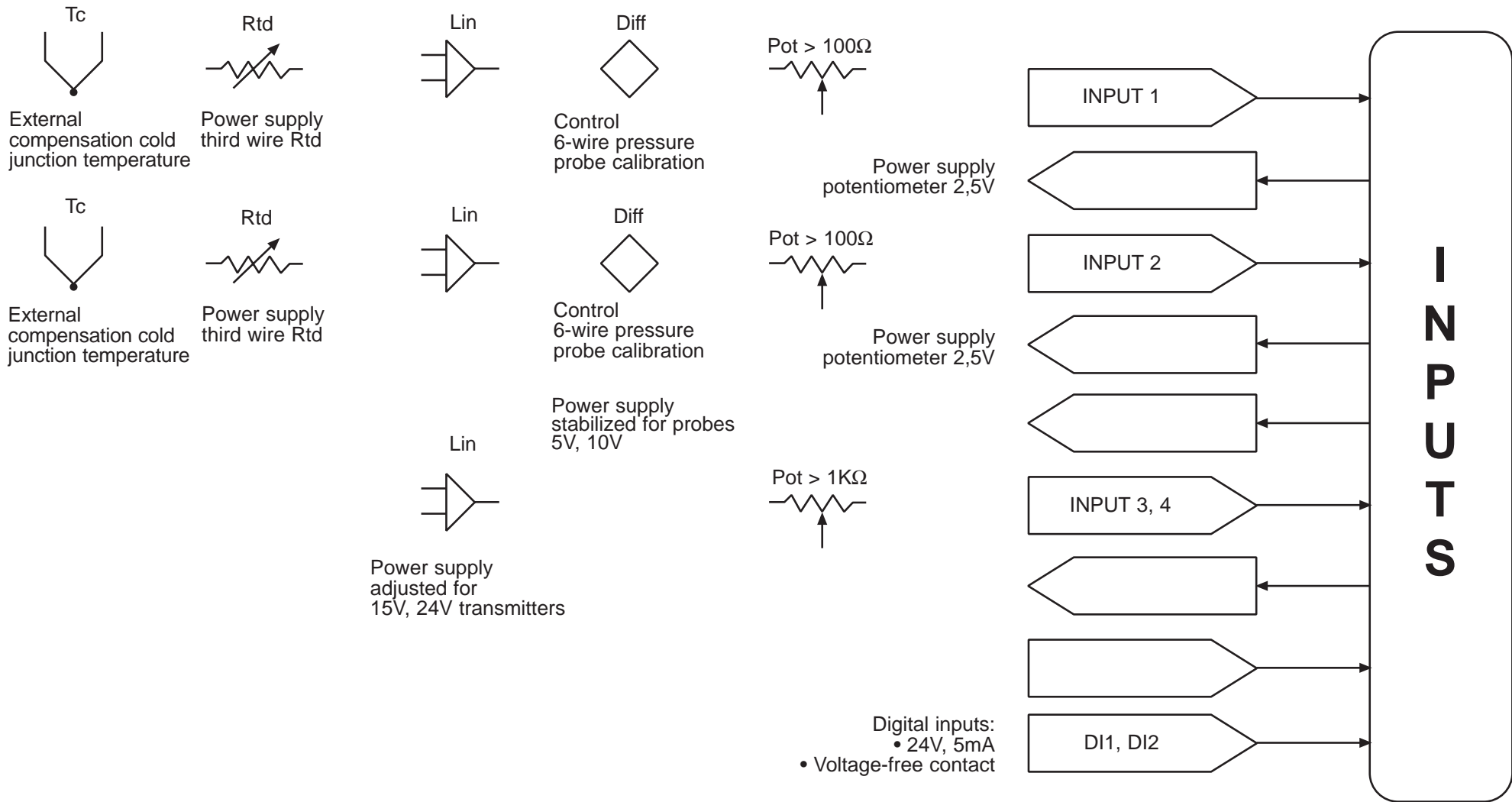

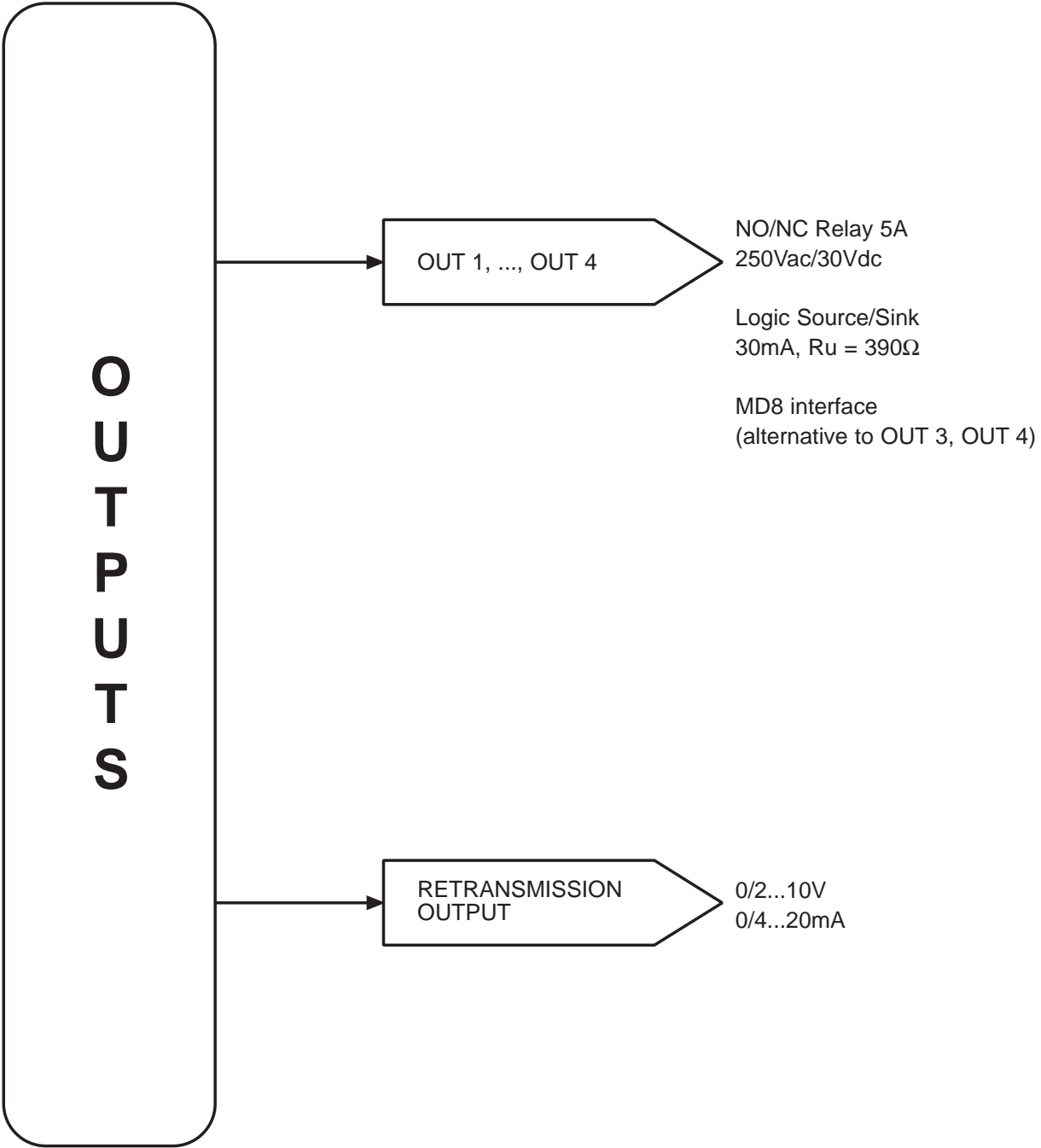

EXAMPLES OF CUSTOM LINEARIZATION

Example of custom linearization: type 0
(at variable amplitude intervals, max. 32)

For positive polarization signals (ex. 0...50mV) 5.00 is the value displayed for minimum input (ex. 0mV);
if 32 intervals are set, 5.32b is the value displayed for input = $5.32A * (f.s. / 10000)$
(ex. if $5.32A = 10000$, 5.32b is the value displayed with input = 50mV)

For symmetrical polarization signals (ex. -25mV...+25mV) 5.00 is the value displayed for minimum input (ex. -25mV);
if 32 intervals are set, 5.32b is the value displayed for input = $5.32A * (f.s. / 10000)$
(ex. if $5.32A = 10000$, 5.32b is the value displayed with input = +25mV)

In case of linearization type 1, ... ,4 5.00A values are acquired directly by its input IN1, ... ,IN4

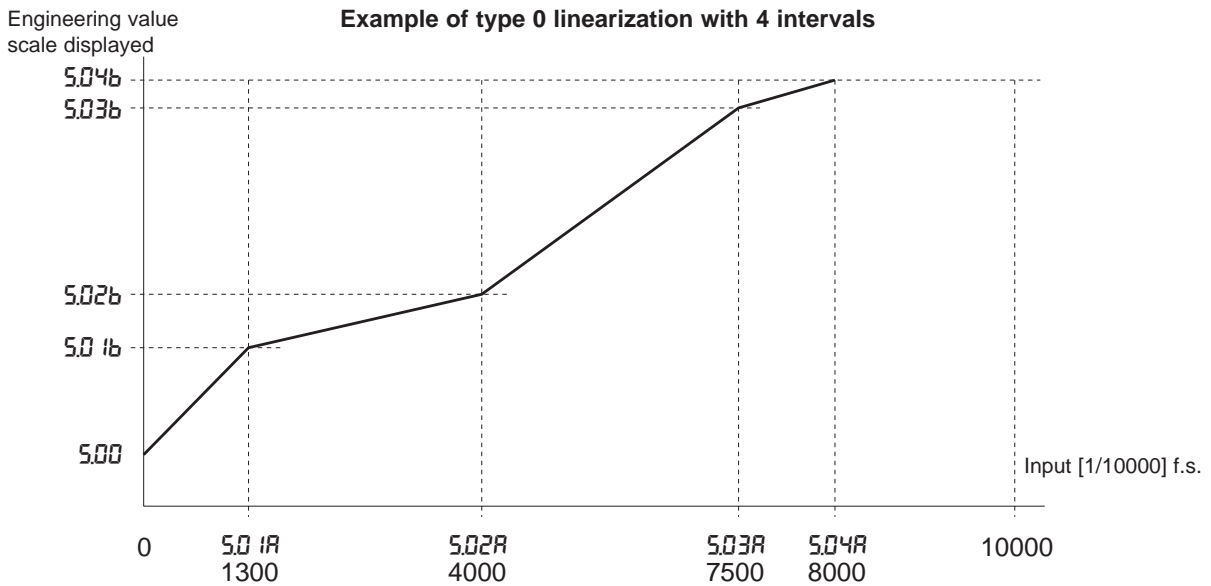

Example of custom linearization: type 5
(at 64 constant amplitude intervals = f.s. / 64)

For positive polarization signals (ex. 0...50mV) 5.00 is the value displayed for minimum input (ex. 0mV);
5.54 is the value displayed for maximum input (ex. 50mV)

For positive polarization signals (ex. -25mV...+25mV) 5.00 is the value displayed for minimum input (ex. -25mV);
5.54 is the value displayed for maximum input (ex. +25mV)

