

# FS-600 Series – No Moving Part, Thermal Dispersion Flow Switch

**Flow Rate Settings:** 0.1 GPM to 11 GPM (0.5 LPM to 41 LPM)

**Port Size:** 1/2" to 1-1/2" (NPT or G thread)

**Setting Type:** Fixed

The FS-600 series uses proven thermal dispersion technology to provide a robust no moving part flow switch even without filtration. The solid state sensor is compatible with both conductive and non-conductive fluids. Suitable for fluids with particulates or slurries, and is immune to changes in media viscosity. The straight through switch is designed for a long life and can be mounted in any orientation and can handle a wide range of flow rates. No moving parts means years of reliable service.

## Specifications

<b>Wetted Materials</b>	
<b>Probe</b>	303 Stainless Steel
<b>Flow Body</b>	316 Stainless Steel
<b>Operating Pressure (Max.)</b>	363 PSIG (25 bar)
<b>Operating Temperature</b>	-14° F to 140°F (-10°C to 60°C)
<b>Power on Delay Time</b>	15 Seconds Max (Output On)
<b>Response Time</b>	10 Seconds Max.
<b>Inlet/Outlet Ports</b>	1/2", 3/4", 1", 1-1/2" NPT 1/2", 3/4", 1", 1-1/2" G Internal
<b>Operating Voltage</b>	24 Vdc or 24Vac +/- 15%
<b>Current Consumption</b>	Less than 50mA
<b>Switch Contact Rating</b>	30Vac@45mA, 42Vdc @65mA
<b>Switch Logic</b>	Normally Open
<b>Ingress Protection</b>	IP65
<b>Set point Accuracy</b>	15%
<b>Set point Differential</b>	20% (Max.)
<b>Electrical Termination</b>	M12 x 1 (4-Pin) (1 meter cable included)
<b>Approvals</b>	CE

## Accessories

Description	Part#
M12 cord Set-1 meter (Red 1, Green 2, Blue 3, Yellow 4) 22 AWG	<b>557703-01M0</b>
M12 cord Set-3 meter (Red 1, Green 2, Blue 3, Yellow 4) 22 AWG	<b>557703-03M0</b>
M12 cord Set-4 meter (Red 1, Green 2, Blue 3, Yellow 4) 22 AWG	<b>557703-04M0</b>
M12 cord Set-5 meter (Red 1, Green 2, Blue 3, Yellow 4) 22 AWG	<b>557703-05M0</b>

## Calorimetric Principle/Thermal Dispersion

The operating principle of the FS-600 flow switch is based on the calorimetric principle. The FS-600 uses the cooling effect of a flowing fluid or gas to monitor the flow rate. The amount of thermal energy that is removed from the tip determines the local flow rate. This temperature-based operating principle can reliably sense the flow of virtually any liquid or gas.

The sensor tip of the FS-600 flow sensor houses two transistors and a heater element. One transistor is located in the sensor tip, closest to the flowing fluid. This transistor is used to detect changes in the flow velocity of the liquid. The second transistor is bonded to the cylindrical wall and is a reference for ambient fluid conditions.

In order to make the sensor sense flow, it is necessary to heat one of the transistors in the probe. When power is applied, the tip of the probe is heated. As the fluid starts to flow, heat will be carried away from the sensor tip. Cooling of the first transistor is a function of how fast heat is conducted away by the flowing liquid. The difference in temperature between the two transistors provides a measurement of fluid velocity past the sensor probe. When fluid velocity is high, the temperature differential is small. As fluid velocity decreases, there is an increase in temperature differential.

CE



## Dimensions

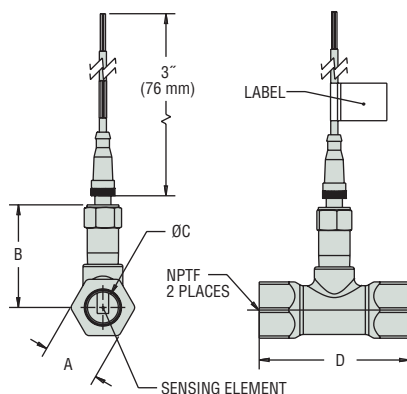

Port Size NPTF	A	B	C	D
1/2"	1.13 (28.7)	2.65 (67.3)	0.62 (15.8)	3.06 (77.8)
3/4"	1.50 (38.1)	2.75 (69.9)	0.824 (20.9)	4.00 (101.6)
1"	1.50 (38.1)	2.75 (69.9)	1.05 (26.7)	4.00 (101.6)
1-1/2"	2.25 (57.1)	3.00 (76.2)	1.61 (40.9)	4.25 (107.9)

- Notes:
1. Standard calibration is in water with units in a horizontal position.
  2. Consult Gems for special applications.

**Wiring Diagram**

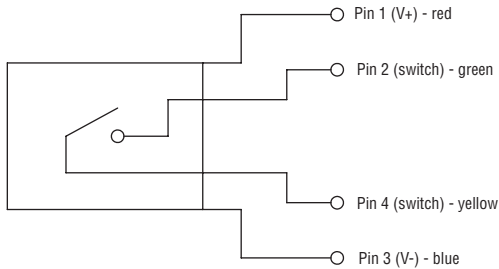

**How To Order – Standard Models**

Specify Part Number based on flow rates for the FS-600 Series per the following chart.

Port Size NPT	Flow Setting		Part Numbers	Port Size NPT	Flow Setting		Part Numbers
	GPM	LPM			GPM	LPM	
1/2"	0.13	0.48	<b>230500-1-5</b>	1"	0.64	2.20	<b>230500-3-5</b>
	0.24	0.90	<b>230500-1-10</b>		0.97	3.20	<b>230500-3-10</b>
	0.35	1.31	<b>230500-1-15</b>		1.31	4.25	<b>230500-3-15</b>
	0.46	1.73	<b>230500-1-20</b>		1.65	5.30	<b>230500-3-20</b>
	0.57	2.14	<b>230500-1-25</b>		1.99	6.5	<b>230500-3-25</b>
	0.68	2.56	<b>230500-1-30</b>		2.32	7.5	<b>230500-3-30</b>
	0.79	2.98	<b>230500-1-35</b>		2.66	8.5	<b>230500-3-35</b>
	0.90	3.39	<b>230500-1-40</b>		3.00	9.5	<b>230500-3-40</b>
	1.01	3.81	<b>230500-1-45</b>		3.33	10.0	<b>230500-3-45</b>
	1.12	4.23	<b>230500-1-50</b>		3.67	12.0	<b>230500-3-50</b>
	1.23	4.64	<b>230500-1-55</b>		4.01	13.0	<b>230500-3-55</b>
1.34	5.06	<b>230500-1-60</b>	4.34	14.0	<b>230500-3-60</b>		
3/4"	0.35	1.31	<b>230500-2-5</b>	1-1/2"	1.48	5.50	<b>230500-4-5</b>
	0.57	2.15	<b>230500-2-10</b>		2.28	8.5	<b>230500-4-10</b>
	0.79	2.99	<b>230500-2-15</b>		3.07	11.6	<b>230500-4-15</b>
	1.01	3.83	<b>230500-2-20</b>		3.86	14.6	<b>230500-4-20</b>
	1.23	4.67	<b>230500-2-25</b>		4.66	17.6	<b>230500-4-25</b>
	1.46	5.51	<b>230500-2-30</b>		5.45	20.6	<b>230500-4-30</b>
	1.68	6.00	<b>230500-2-35</b>		6.0	22.7	<b>230500-4-35</b>
	1.90	7.00	<b>230500-2-40</b>		7.0	26.5	<b>230500-4-40</b>
	2.12	8.00	<b>230500-2-45</b>		8.0	30.3	<b>230500-4-45</b>
	2.34	9.00	<b>230500-2-50</b>		9.0	34.1	<b>230500-4-50</b>
	2.57	10.00	<b>230500-2-55</b>		10.0	37.9	<b>230500-4-55</b>
2.79	11.00	<b>230500-2-60</b>	11.0	41.6	<b>230500-4-60</b>		

Notes:  
 1. G threads are available upon request. Minimum order quantities apply. Contact factory.  
 2. -5 through -60 = fluid velocity (cm/s)

**Fluid Velocity vs. Flow Rate in GPM/LPM**

1/2" NPT Ports (1/2" G Port)

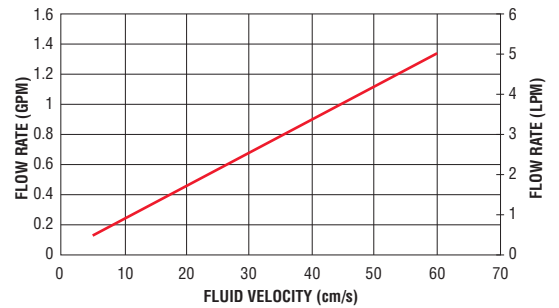

3/4" NPT and 1" NPT Ports (3/4" and 1" G Ports)

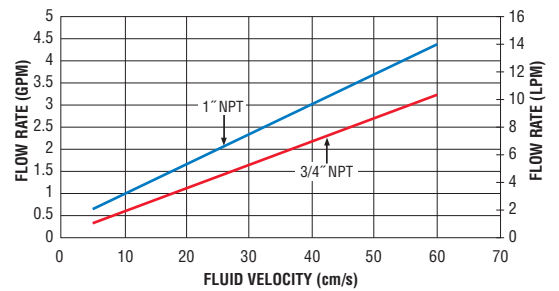

1-1/2" NPT Ports (1-1/2" G Ports)

