

## XT-1000 Series

### Magnetostrictive Level Sensor

- ▶ Measuring accuracy up to  $\pm 0.008''$  (0.2 mm)
- ▶ Resolution better than  $0.004''$  (0.1 mm)
- ▶ Temperature-compensated
- ▶ 2-wire terminal (4-20mA)
- ▶ Measuring range along the complete probe length
- ▶ Lengths of  $8''$  to  $157''$  (200 to 4,000 mm)

The high-precision and robust level sensor is designed to provide continuous gauging of liquid media levels in tanks. The measuring principle used by the sensor exploits the physical effect of magnetostriction and is largely unaffected by temperature. Magnetostriction is particularly ideal where level measurements are required to be extremely accurate, e.g. in the chemical industry. The level sensor outputs measuring signals in the range 4 to 20 mA. Available in lengths of  $8''$  to  $157''$  (200 to 6,000 mm), it is compatible with a variety of tank dimensions. It also comes in the following versions:

The explosion-proof version of the level sensor can be installed in potentially explosive atmospheres in which electrical equipment of category 1 (zone 0) or category 1/2 (zone 0/1) are required. Operating on the digital HART protocol, the HART level sensor is able to output the position of the first, second or both floats.

#### Specifications

<b>Housing</b>	
Protection Type	IP 68
Material	Stainless Steel
Cable Diameter	0.19" to 0.394" (5 to 10 mm)
<b>Probe Tube</b>	
Diameter	0.472" (12 mm)
Material	Stainless Steel 316 Ti; Hastelloy C
Length	8" to 157" (200 to 4,000 mm)
<b>Electrical</b>	
Connection	2-wire
Supply	10 to 30 VDC
Current Signal	4 to 20 mA
Error Message	Adjustable to 3.6 or 21.5 mA
<b>Measuring Accuracy</b>	
Filling Level	Up to $0.020''$ (0.5 mm)
Resolution	Up to $0.004''$ (0.1 mm)
Analog Part	$\pm 0.1\%$ / K, resolution better 0.5 $\mu$ A

#### Operating Principle

Inside the probe tube there is a rigid wire (1) made of magnetostrictive material. The sensor circuitry emits pulses of current (2) through the wire, generating a circular magnetic field (3). The level transmitter is a magnet (4), which is integrated into the float. Its magnetic field magnetizes the wire axially. Since the two magnetic fields are superimposed, around the float magnet a torsion wave (5) is generated which runs in both directions along the wire. One wave runs directly to the probe head while the other is reflected at the bottom of the probe tube. The time is measured between emission of the current pulse and arrival of the wave at the probe head. The position of the float is determined on the basis of the transit times.

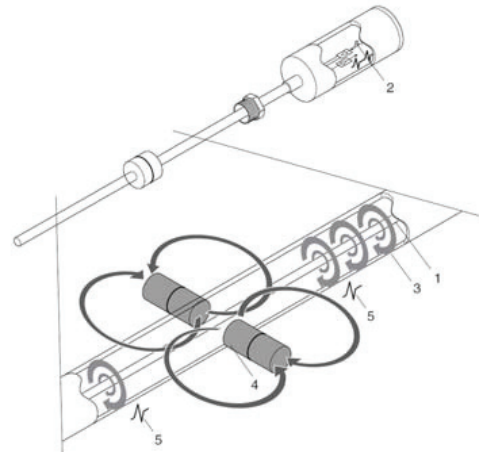

**Mounting Types**

Size	Material	Mounting Type	Code
R 1-1/2*	Brass	Threaded	<b>1</b>
2" NPT	316 Stainless Steel	Threaded	<b>2</b>
3" - 150#		Flange	<b>3</b>

\* Includes adjustable mounting option

**Float Types**

Min. Specific Gravity	Max. Operating Pressure	Float Type	Material	Diameter	Code
≥0.50	290 psi (20 bar)	Ball	Titanium	1.99" (50 mm)	<b>11</b>
≥0.60			316 Ti	2.05" (52 mm)	<b>02</b>
≥0.70	145 psi (10 bar)	Cylinder	C276	1.81" (46 mm)	<b>12</b>
	232 psi (16 bar)				<b>07</b>
≥0.85	290 psi (20 bar)	Ball	316 Ti	1.69" (43 mm)	<b>09</b>
≥0.95	725 psi (50 bar)				<b>03</b>

**Temperature Ranges**

<b>Ambient</b>	-40°F to +185°F (-40°C to +85°C)
----------------	----------------------------------

**Process Medium**

Temperature	Range	Code
Standard	-40°F to +257°F (-40°C to +125°C)	<b>1</b>
Low	-85°F to +257°F (-65°C to +125°C)	<b>4</b>
High	-40°F to +482°F (-40°C to +250°C)	<b>3</b>
Highest	-40°F to +842°F (-40°C to +450°C)	<b>5</b>

**How to Order**

Use the **bold** characters from the chart below to construct a product code

**XT-1000 - X - XXX - XX - X - X - X - X**

<p>Probe Tube Material</p> <p><b>B</b> - 4-20 mA</p> <p><b>N</b> - 0.5-4.5 V</p> <p>Probe Lengths</p> <p>For flanged version state the fitting length</p> <p>Length in inches</p> <p>Float Type</p> <p><b>00</b> - None</p> <p><b>02</b> - Ball dia. 2.05" (52 mm), 316 Ti, 290 psi (20 bar), ≥ 0.60 SG</p> <p><b>03</b> - Ball dia. 1.69" (43 mm), 316 Ti, 725 psi (50 bar), ≥ 0.95 SG</p> <p><b>07</b> - Cylinder dia. 1.69" (43 mm), 316 Ti, 232 psi (16 bar), ≥ 0.70 SG</p> <p><b>09</b> - Ball dia. 1.69" (43 mm), 316 Ti, 290 psi (20 bar), ≥ 0.85 SG</p> <p><b>10</b> - Ball dia. 2.05" (52 mm), 316 Ti, 40 bar, ≥ 0.70 SG</p> <p><b>11</b> - Ball dia. 1.99" (50 mm), Titanium, 20 bar, ≥ 0.50 SG</p> <p><b>12</b> - Cylinder dia. 1.81" (46 mm), C276, 10 bar, ≥ 0.70 SG</p>	<p>HART</p> <p><b>0</b> - None</p> <p><b>1</b> - Hart Protocol</p> <p>Certificate</p> <p><b>0</b> - None</p> <p><b>1</b> - Ex (ATEX)</p> <p>Medium Temperature Range</p> <p><b>1</b> - Standard Temperature</p> <p><b>3</b> - High Temperature</p> <p><b>4</b> - Low Temperature</p> <p><b>5</b> - Highest Temperature</p> <p>Mounting Type</p> <p><b>0</b> - None</p> <p><b>1</b> - Threaded, Brass, R 1-1/2</p> <p><b>2</b> - 2" NPT, Stainless Steel 316</p> <p><b>3</b> - 3" 150# Flange, Stainless Steel</p>
---	---

**Dimensions – in. (mm)**

**Threaded**

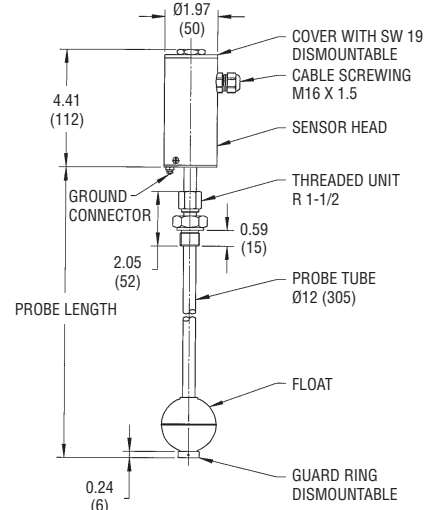

**Flange**

