

# SENSORS PLASTIC INDUSTRY THERMOCOUPLES — MELT

## Adjustable Plastic Melt Thermocouple Also Available with Hastalloy Tip for Max. Abrasion Resistance

ADJUSTABLE MELT ASSEMBLY	
CATALOG NUMBER	"L" DIMENSION
Single element <b>PTC-3110</b>	3"
	4"
	5"
	6"
Dual Element <b>PTC-3110-D</b>	3"
	4"
	5"
	6"

To Order Give: **PTC** - **J** -  
Catalog No. ANSI Type "L"

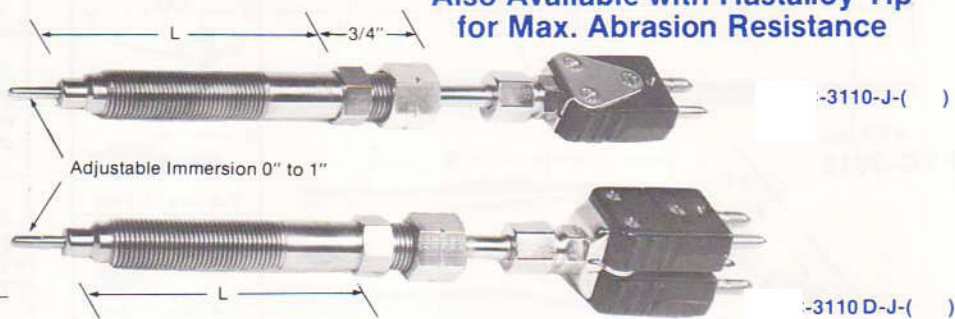

THERMOCOUPLE REPLACEMENT	
CATALOG NUMBER	FOR BARREL DIMENSION "L"
Single element <b>PTC-3111</b>	3"
	4"
	5"
	6"
Dual element <b>PTC-3111-D</b>	3"
	4"
	5"
	6"

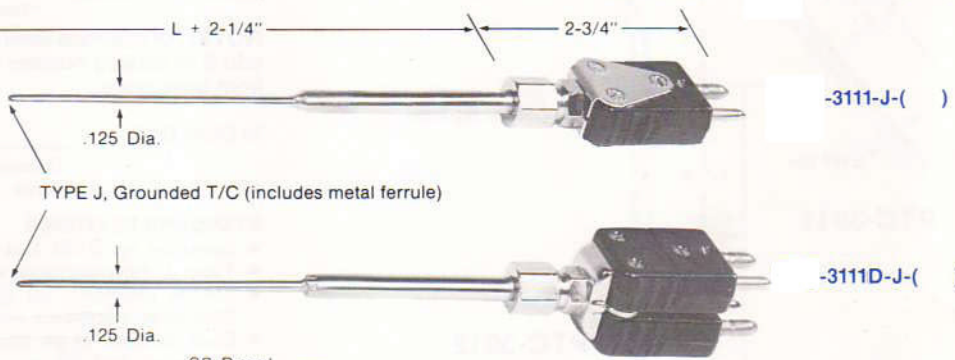

BARREL REPLACEMENT (Includes Metal Ferrule and Hex Nut)	
CATALOG NUMBER	"L" DIMENSION
<b>PTC-3112</b>	3"
	4"
	5"
	6"

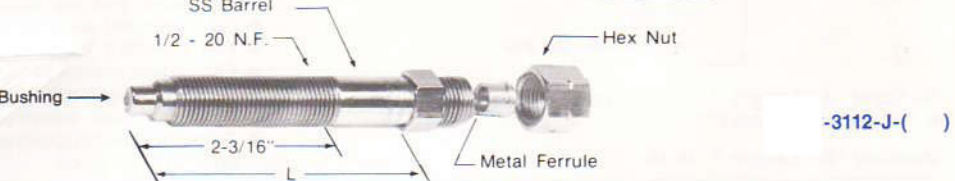

FIXED IMMERSION MELT TC ASSEMBLY		
CATALOG NO.	"L"	"A"
Single element		
Rigid Extension <b>PTC-3070</b>	3"	Specify (0, 1/4", 1/2", 3/4", or 1")
Flexible Exten. <b>PTC-3090</b>	4"	
	5"	
	6"	
Dual element		
Rigid Extension <b>PTC-3070-D</b>	3"	Specify (0, 1/4", 1/2", 3/4", or 1")
Flexible Exten. <b>PTC-3090-D</b>	4"	
	5"	
	6"	

## Fixed Immersion Plastic Melt Thermocouple

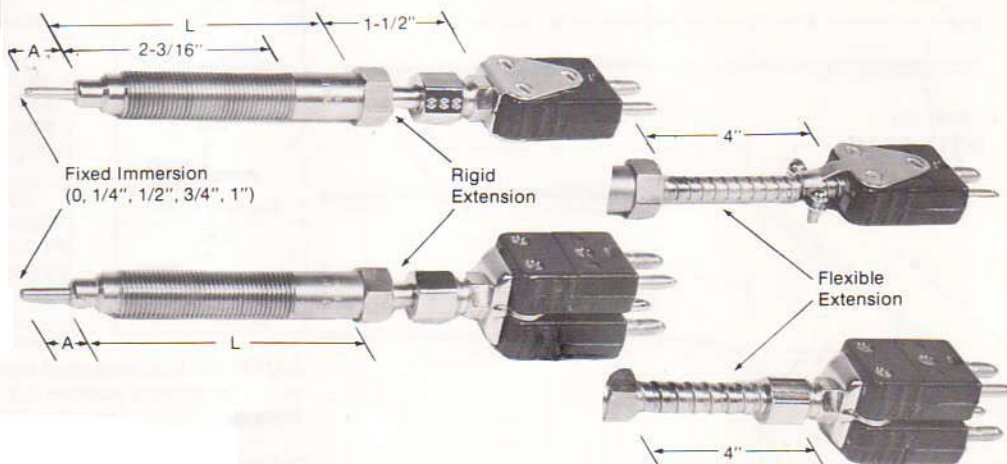

### STANDARD FEATURES & OPTIONS

- Stainless steel construction
- 1/8" Dia., Type J, grounded junction, Marlox Thermocouple standard
- Single or Dual Element Thermocouple
- Quick Connector Plug Termination
- Teflon Bushing Standard
- Ceramic Bushing available
- Add suffix C to catalog no., i.e. PTC-3113C-J-3"
- Other Thermocouple Types available e.g. K, T, E use proper ANSI code and add 10% to list price.
- For additional flexible extension
- For additional Barrel Length "L"
- For Hastalloy Tip use suffix HST

### Construction detail for plastic melt thermocouples

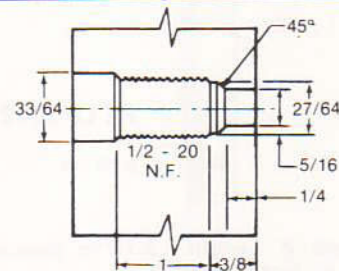
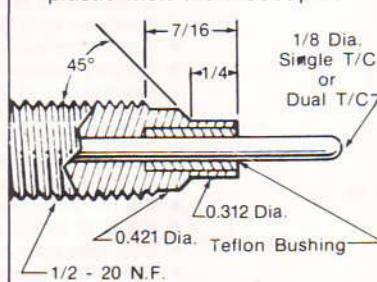

**Recommended dimensions** in plastic molding machine barrel for correct mounting of plastic melt extruder type thermocouple.

Since 1952

**Marlin**