



Displays Programmable displays with a wide selection of inputs and outputs for display of temperature, volume and weight, etc. Feature linearisation, scaling, and difference measurement functions for programming via PReset software.



Ex barriers Interfaces for analogue and digital signals as well as HART® signals between sensors / I/P converters / frequency signals and control systems in Ex zone 0, 1 & 2 and for some modules in zone 20, 21 & 22.



Isolation Galvanic isolators for analogue and digital signals as well as HART® signals. A wide product range with both loop-powered and universal isolators featuring linearisation, inversion, and scaling of output signals.



Temperature A wide selection of transmitters for DIN form B mounting and DIN rail modules with analogue and digital bus communication ranging from application-specific to universal transmitters.



Universal PC or front programmable modules with universal options for input, output and supply. This range offers a number of advanced features such as process calibration, linearisation and auto-diagnosis.



DK Side 1

UK Page 25

FR Page 49

DE Seite 73

4 2 2 2

**Universal
I/f Converter**

No. 4222V100-IN (0647)
From ser. no.060867001



SIGNALS THE BEST



Rullende hjælpetekster i displaylinie 3

- [01] Angiv korrekt password
- [02] Gå til avanceret opsætningsmenu?
- [03] Vælg temperaturindgang
 - Vælg potentiometerindgang
 - Vælg lineær modstandsindgang
 - Vælg strømindgang
 - Vælg spændingsindgang
- [04] Vælg 0.0-1 V indgangsområde
 - Vælg 0.2-1 V indgangsområde
 - Vælg 0-2.5 V indgangsområde
 - Vælg 0.5-2.5 V indgangsområde
 - Vælg 0-5 V indgangsområde
 - Vælg 1-5 V indgangsområde
 - Vælg 0-10 V indgangsområde
 - Vælg 2-10 V indgangsområde
- [05] Vælg 0-20 mA indgangsområde
 - Vælg 4-20 mA indgangsområde
- [06] Vælg 2-leder følertilslutning
 - Vælg 3-leder følertilslutning
 - Vælg 4-leder følertilslutning
- [07] Indstil 0% modstandsværdi
- [08] Indstil 100% modstandsværdi
- [09] Vælg Celsius som temperaturenhed
 - Vælg Fahrenheit som temperaturenhed
- [10] Vælg TC-følertype
 - Vælg Ni-følertype
 - Vælg Pt-følertype
- [11] Vælg displayenheder
- [12] Vælg kommaplacering
- [13] Indstil displayvisning lav
- [14] Indstil displayvisning høj
- [16] Vælg Pt10 som følertype
 - Vælg Pt20 som følertype
 - Vælg Pt50 som følertype
 - Vælg Pt100 som følertype
 - Vælg Pt200 som følertype
 - Vælg Pt250 som følertype
 - Vælg Pt300 som følertype
 - Vælg Pt400 som følertype
 - Vælg Pt500 som følertype
 - Vælg Pt1000 som følertype
- [17] Vælg Ni50 som følertype
 - Vælg Ni100 som følertype
 - Vælg Ni120 som følertype
 - Vælg Ni1000 som følertype
- [18] Vælg TC-B som følertype
 - Vælg TC-E som følertype
 - Vælg TC-J som følertype
 - Vælg TC-K som følertype
 - Vælg TC-L som følertype
 - Vælg TC-N som følertype
 - Vælg TC-R som følertype
 - Vælg TC-S som følertype
 - Vælg TC-T som følertype
 - Vælg TC-U som følertype
 - Vælg TC-W3 som følertype
 - Vælg TC-W5 som følertype
 - Vælg TC-Lr som følertype
- [19] Vælg 50% duty cycle udgang
 - Vælg programmerbar impulstid
- [20] Vælg Hz som udgangstype
 - Vælg impulser/minut som udgangsenhed
 - Vælg impulser/time som udgangsenhed
 - Vælg impulser/dag som udgangsenhed
- [21] Indstil udgangsfrekvens for 0% indgang
- [22] Indstil udgangsfrekvens for 100% indgang
- [23] Indstil nedre cut-off frekvens
- [24] Indstil impulstid i millisekunder
- [25] Ingen følerfejlsaktion - udefineret status ved fejl
 - Udsend specifik frekvens ved fejl på indgang?
- [26] Indstil udgangsfrekvens ved fejl på indgang
- [40] Indstil udgangens reaktionstid i sekunder
- [41] Indstil temperatur for frekvensudgang lav
- [42] Indstil temperatur for frekvensudgang høj
- [43] Gå til indstillinger for sprog
 - Gå til password-indstilling
 - Gå til simuleringstilstand
 - Udfør proceskalibrering
 - Gå til displayopsætning
 - Udfør memory-operationer
- [44] Overfør gemt opsætning til modul
 - Gem modulopsætning i displayfront
- [45] Juster LCD-kontrast
- [46] Juster LCD-baggrundsbelysning
- [47] Skriv en TAG - max. 6 karakterer
- [48] Udgangsfrekvens vises i displaylinie 3
 - TAG vises i displaylinie 3
- [49] Kalibrer indgang lav til procesværdi?
- [50] Kalibrer indgang høj til procesværdi?
- [51] Aktiver simuleringmode
- [52] Indstil simulering indgangsværdi
- [54] Aktiver passwordbeskyttelse?
- [55] Angiv nyt password
- [59] Vælg sprog
- [60] Brug proceskalibreringsværdier?
- [61] Indstil værdi for lavt kalibreringspunkt
- [62] Indstil værdi for højt kalibreringspunkt

UNIVERSAL I/f CONVERTER

PREASY 4222

CONTENTS

Warnings	26
Safety instructions.....	27
Declaration of Conformity	29
How to dismantle SYSTEM 4000.....	30
Advanced features	31
Application	31
Technical characteristics	31
PR 4501 display / programming front.....	32
Applications.....	33
Order codes	34
Electrical specifications.....	34
Configuration of sensor error detection.....	37
Display readout on the 4501:	
Display outside range.....	37
Sensor error detection limits.....	38
Signal conditioning limits	38
Error indications	38
Connections	39
Block diagram	40
Configuration / operating the function keys	41
Routing diagram.....	44
Routing diagram, advanced settings (ADV.SET).....	47
Scrolling help text in display line 3	48



GENERAL

WARNING!

This module is designed for connection to hazardous electric voltages. Ignoring this warning can result in severe personal injury or mechanical damage. To avoid the risk of electric shock and fire, the safety instructions of this manual must be observed and the guidelines followed. The specifications must not be exceeded, and the module must only be applied as described in the following. Prior to the commissioning of the module, this manual must be examined carefully. Only qualified personnel (technicians) should install this module. If the equipment is used in a manner not specified by the manufacturer, the protection provided by the equipment may be impaired.



HAZARDOUS VOLTAGE

WARNING!

Until the module is fixed, do not connect hazardous voltages to the module.
The following operations should only be carried out on a disconnected module and under ESD safe conditions:
General mounting, connection and disconnection of wires.
Troubleshooting the module.



Repair of the module and replacement of circuit breakers must be done by PR electronics A/S only.



INSTALLATION

WARNING

SYSTEM 4000 must be mounted on a DIN rail according to DIN 46277.



WARNING

Do not open the front plate of the module as this will cause damage to the connector for the display / programming front PR 4501. This module contains no DIP-switches or jumpers.

SYMBOL IDENTIFICATION



Triangle with an exclamation mark: Warning / demand. Potentially lethal situations.



The CE mark proves the compliance of the module with the essential requirements of the directives.



The double insulation symbol shows that the module is protected by double or reinforced insulation.

SAFETY INSTRUCTIONS

DEFINITIONS:

Hazardous voltages have been defined as the ranges: 75 to 1500 Volt DC, and 50 to 1000 Volt AC.

Technicians are qualified persons educated or trained to mount, operate, and also troubleshoot technically correct and in accordance with safety regulations.

Operators, being familiar with the contents of this manual, adjust and operate the knobs or potentiometers during normal operation.

RECEIPT AND UNPACKING:

Unpack the module without damaging it and make sure that the manual always follows the module and is always available. The packing should always follow the module until this has been permanently mounted.

Check at the receipt of the module whether the type corresponds to the one ordered.

ENVIRONMENT:

Avoid direct sunlight, dust, high temperatures, mechanical vibrations and shock, as well as rain and heavy moisture. If necessary, heating in excess of the stated limits for ambient temperatures should be avoided by way of ventilation.

All modules fall under Installation Category II, Pollution Degree 1, and Insulation Class II.

MOUNTING:

Only technicians who are familiar with the technical terms, warnings, and instructions in the manual and who are able to follow these should connect the module.

Should there be any doubt as to the correct handling of the module, please contact your local distributor or, alternatively,

PR electronics A/S, Lerbakken 10, DK-8410 Rønede, Denmark,
tel: +45 86 37 26 77.

Mounting and connection of the module should comply with national legislation for mounting of electric materials, i.a. wire cross section, protective fuse, and location. Descriptions of input / output and supply connections are shown in the block diagram and side label.

The following apply to fixed hazardous voltages-connected modules:

The max. size of the protective fuse is 10 A and, together with a power switch, it should be easily accessible and close to the module. The power switch should be marked with a label indicating that it will switch off the voltage to the module.

Year of manufacture can be taken from the first two digits in the serial number.

UL INSTALLATION REQUIREMENTS:

Use 60/75°C copper conductors only.

For use only in pollution degree 2 or better.

Max. ambient temperature..... 60°C

Max. wire size..... AWG 26-14

UL file number..... E231911

CALIBRATION AND ADJUSTMENT:

During calibration and adjustment, the measuring and connection of external voltages must be carried out according to the specifications of this manual. The technician must use tools and instruments that are safe to use.

NORMAL OPERATION:

Operators are only allowed to adjust and operate modules that are safely fixed in panels, etc., thus avoiding the danger of personal injury and damage. This means there is no electrical shock hazard, and the module is easily accessible.

CLEANING:

When disconnected, the module may be cleaned with a cloth moistened with distilled water or ethyl alcohol.

LIABILITY:

To the extent that the instructions in this manual are not strictly observed, the customer cannot advance a demand against PR electronics A/S that would otherwise exist according to the concluded sales agreement.

DECLARATION OF CONFORMITY

As manufacturer

PR electronics A/S
Lerbakken 10
DK-8410 Rønede

hereby declares that the following product:

Type: 4222
Navn: Universal I/f converter

is in conformity with the following directives and standards:

The EMC Directive 2004/108/EC and later amendments
EN 61326

For specification of the acceptable EMC performance level, refer to the electrical specifications for the module.

The Low Voltage Directive 73/23/EEC and later amendments
EN 61010-1

Rønede, 25 Oct. 2006



Peter Rasmussen
Manufacturer's signature

HOW TO DISMANTLE SYSTEM 4000

First, remember to demount the connectors with hazardous voltages.



Picture 1:

Detach the module from the DIN rail by lifting the bottom lock.

UNIVERSAL I/f CONVERTER PREASY 4222

- *Input for RTD, TC, Ohm, potentiometer, mA and V*
- *Frequency output NPN, PNP and TTL*
- *Generates frequencies from 0.001...25000 Hz*
- *2-wire supply > 16 V*
- *Universal AC or DC supply*

Advanced features:

- Programmable by way of detachable display front (4501), process calibration, signal simulation, password protection, error diagnostics and help text available in several languages.

Application:

- Linearised, electronic temperature measurement with RTD or TC sensor.
- Conversion of linear resistance variation to a frequency signal, e.g. from solenoids and butterfly valves or linear movements with attached potentiometer.
- Power supply and signal isolator for 2-wire transmitters.
- Process control by way of a frequency signal transmitted to e.g. a PLC or a process computer.
- Galvanic separation and conversion of analogue signals to frequency signals.

Technical characteristics:

- When 4222 is used in combination with the 4501 display / programming front, all operational parameters can be modified to suit any application. As the 4222 is designed with electronic hardware switches, it is not necessary to open the module for setting of DIP-switches.
- A green front LED indicates normal operation.
- Continuous check of vital stored data for safety reasons.
- 3-port 2.3 kVAC galvanic isolation.

PR 4501 DISPLAY / PROGRAMMING FRONT



Functionality:

The simple and easily understandable PReasy menu structure and the explanatory help texts guide you effortlessly and automatically through the configuration steps, thus making the product very easy to use. Functions and configuration options are described in the section "Configuration / operating the function keys".

Application:

- Communications interface for modification of operational parameters in 4222.
- Can be moved from one 4222 module to another and download the configuration of the first converter to subsequent converters.
- Fixed display for readout of process data and status.

Technical characteristics:

- LCD display with 4 lines; line 1 (H = 5.57 mm) shows input signal, line 2 (H = 3.33 mm) shows units. Line 3 alternates between digital output value and scaling (kHz, Hz, mHz, P/m, P/h, P/d) or shows TAG no. Line 4 shows tendency readout for the input signal and communication status.
- Programming access can be blocked by assigning a password. The password is saved in the converter in order to ensure a high degree of protection against unauthorised modifications to the configuration.

Mounting / installation:

- Click 4501 onto the front of 4222.

Applications

Input signals:

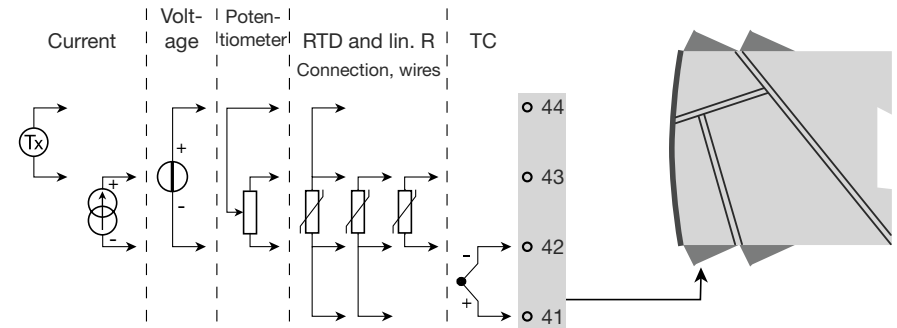

Output signals:

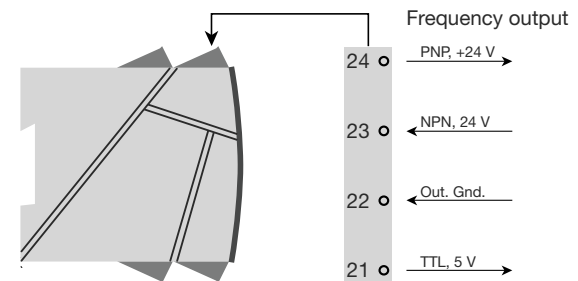

Supply:

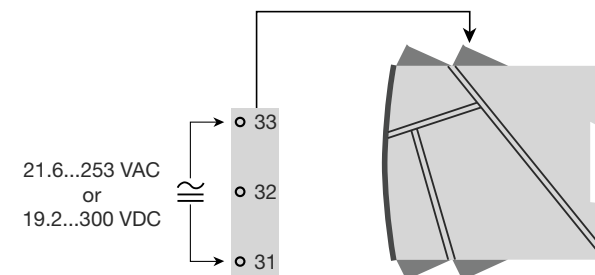

ORDER CODES:

4222 = Universal I/f converter

4501 = Display / programming front

Electrical specifications:

Specifications range..... -20°C to +60°C

Common specifications:

Supply voltage, universal 21.6...253 VAC, 50...60 Hz or
19.2...300 VDC

Max. consumption ≤ 2.5 W

Fuse..... 400 mA SB / 250 VAC

Isolation voltage, test / operation 2.3 kVAC / 250 VAC

Communications interface Programming front 4501

Signal / noise ratio Min. 60 dB (0...100 kHz)

Response time (0...90%, 100...10%), programmable:

Temperature input..... 1...60 s

mA / V input..... 0,4...60 s

Calibration temperature 20...28°C

Accuracy, the greater of the general and basic values:

General values		
Input type	Absolute accuracy	Temperature coefficient
All	≤ ±0.1% of span	≤ ±0.01% of span / °C

Basic values		
Input type	Basic accuracy	Temperature coefficient
mA	≤ ±4 µA	≤ ±0.4 µA / °C
Volt	≤ ±20 µV	≤ ±2 µV / °C
Pt100	≤ ±0.2°C	≤ ±0.01°C / °C
Linear resistance	≤ ±0.1 Ω	≤ ±0.01 Ω / °C
Potentiometer	≤ ±0.1 Ω	≤ ±0.01 Ω / °C
TC type: E, J, K, L, N, T, U	≤ ±1°C	≤ ±0.05°C / °C
TC type: B, R, S, W3, W5, LR	≤ ±2°C	≤ ±0.2°C / °C

EMC immunity influence	< ±0.5% of span
Extended EMC immunity: NAMUR NE 21, A criterion, burst	< ±1% of span

Auxiliary supplies:

2-wire supply (terminal 44...43)..... 25...16 VDC / 0...20 mA

Max. wire size..... 1 x 2.5 mm² stranded wire

Screw terminal torque..... 0.5 Nm

Relative humidity..... < 95% RH (non-cond.)

Dimensions, without display front (HxBxD).. 109 x 23.5 x 104 mm

Dimensions, with display front (HxBxD)..... 109 x 23.5 x 116 mm

Tightness (enclosure / terminals) IP50 / IP20

Weight 155 g / 170 g with 4501

RTD, linear resistance and potentiometer input:

Input type	Min. value	Max. value	Standard
Pt100	-200°C	+850°C	IEC60751
Ni100	-60°C	+250°C	DIN 43760
Lin. resistance	0 Ω	10000 Ω	-
Potentiometer	10 Ω	100 kΩ	-

Input for RTD types:

Pt10, Pt20, Pt50, Pt100, Pt200, Pt250, Pt300, Pt400, Pt500, Pt1000

Ni50, Ni100, Ni120, Ni1000

Cable resistance per wire (max.), RTD..... 50 Ω

Sensor current, RTD..... Nom. 0.2 mA

Effect of sensor cable resistance

(3- / 4-wire), RTD..... < 0.002 Ω / Ω

Sensor error detection, RTD Yes

Short circuit detection, RTD..... < 15 Ω

TC input:

Type	Min. value	Max. value	Standard
B	+400°C	+1820°C	IEC 60584-1
E	-100°C	+1000°C	IEC 60584-1
J	-100°C	+1200°C	IEC 60584-1
K	-180°C	+1372°C	IEC 60584-1
L	-200°C	+900°C	DIN 43710
N	-180°C	+1300°C	IEC 60584-1
R	-50°C	+1760°C	IEC 60584-1
S	-50°C	+1760°C	IEC 60584-1
T	-200°C	+400°C	IEC 60584-1
U	-200°C	+600°C	DIN 43710
W3	0°C	+2300°C	ASTM E988-90
W5	0°C	+2300°C	ASTM E988-90
LR	-200°C	+800°C	GOST 3044-84

Cold junction compensation (CJC)

via internally mounted sensor < ±1.0 °C

Sensor error detection, all TC types Yes

Sensor error current:

when detecting Nom. 2 µA

else 0 µA

Current input:

Measurement range -1...25 mA

Programmable measurement ranges 0...20 and 4...20 mA

Input resistance Nom. 20 Ω + PTC 50 Ω

Sensor error detection:

loop break 4...20 mA Yes

Voltage input:

Measurement range -20 mV...12 VDC

Programmable measurement ranges 0...1 / 0.2...1 / 0...2.5 / 0.5...2.5 / 0...5 / 1...5 / 0...10 and 2...10 VDC

Input resistance Nom. 10 MΩ

Output:

Frequency output:

Frequency range 0...25000 Hz

Min. frequency (span) 0.001 Hz

Duty cycle (0...25000 Hz) 50% or

Programmable pulse time (f ≤ 500 Hz) 1...1000 ms (max. 90% duty cycle)

PNP output:

I_{out} max. 30 mA

V_{out} 24 VDC ± 10%

C_{out} 10 nF

R_{out} typ. 20 Ω

Electromechanical counter 24 V / 135 mA / 20 ms / ≤ 10 Hz

NPN output:

I_{sink} max. 150 mA

I_{sink} max. peak 300 mA

External voltage (terminal 23) max. 55 VDC

C_{out} 10 nF

R_{out} typ. 10 Ω

TTL output:

I_{sink/source} max. 15 mA

I_{sink/source} peak 100 mA

V_{out} 5 V ±5%

C_{out} 10 nF

R_{out} typ. 55 Ω

Sensor error detection:

Programmable 0...26250 Hz

Observed authority requirements:

Standard:

EMC 2004/108/EC

Emission and immunity EN 61326

LVD 73/23/EEC EN 61010-1

UL, Standard for Safety UL 508

of span = of the currently selected measurement range

Configuration of sensor error detection:

Module:	Configuration	Sensor error detection:
4222	OUT.ERR=NO	OFF
	Else:	ON

Display readout on the 4501:

Display outside range:

Display readout below min. / above max. (-1999, 9999):			
Input	Range	Flashing readout	Limit
All	All	-1999	Display readout <-1999
		9999	Display readout >9999

Sensor error detection limits:

Sensor error detection (SE.BR, SE.SH):			
Input	Range	Readout	Limit
CURR	Loop break (4...20 mA)	SE.BR	$\leq 3.6 \text{ mA}$; $\geq 21 \text{ mA}$
POTM	All, SE.BR on all 3-wire	SE.BR	$> \text{ca. } 126 \text{ k}\Omega$
LIN.R	0...800 Ω	SE.BR	$> \text{ca. } 875 \text{ }\Omega$
	0...10 k Ω	SE.BR	$> \text{ca. } 11 \text{ k}\Omega$
TEMP	TC	SE.BR	$> \text{ca. } 750 \text{ k}\Omega / (1,25 \text{ V})$
		SE.BR	$> \text{ca. } 15 \text{ k}\Omega$
		SE.SH	$< \text{ca. } 15 \text{ }\Omega$
	RTD: 2-, 3- and 4-wire No SE.SH for Pt10, Pt20 and Pt50		

Signal conditioning limits:

Outside range readout (IN.LO, IN.HI): If the valid range of the A/D converter or the polynomial is exceeded.			
Input	Range	Readout	Limit
VOLT	0...1 V / 0.2...1 V	IN.LO	$< -25 \text{ mV}$
		IN.HI	$> 1.2 \text{ V}$
	0...2.5 / 0.5...2.5 / 0...5 V / 1...5 V / 0...10 V / 2...10 V	IN.LO	$< -25 \text{ mV}$
		IN.HI	$> 12 \text{ V}$
CURR	0...20 mA / 4...20 mA	IN.LO	$< -1.05 \text{ mA}$
		IN.HI	$> 25.05 \text{ mA}$
LIN.R	0...800 Ω	IN.LO	$< 0 \text{ }\Omega$
		IN.HI	$> 1075 \text{ }\Omega$
	0...10 k Ω	IN.LO	$< 0 \text{ }\Omega$
		IN.HI	$< 110 \text{ k}\Omega$
POTM	Min. readout = 0%, Max. readout = 100%	IN.LO	$< -0.5 \%$
		IN.HI	$> 100.5 \%$
TEMP	TC / RTD	IN.LO	$< \text{temperature range } -2^\circ\text{C}$
		IN.HI	$> \text{temperature range } +2^\circ\text{C}$

Error indications:

Readout at hardware error		
Error search	Readout	Cause
Test of internal CJC sensor	CJ.ER	CJC sensor defect or temperature outside range
Checksum test of the configuration in FLASH	FL.ER	Error in FLASH
Communications test 4501 / 4222	NO.CO	Connection error
Check that input signal matches input configuration	IN.ER	1) Error levels on input
Check that saved configuration in 4501 matches module	TY.ER	Configuration is not 4222

! All error indications flash once per second. The help text explains the error.
1) The error is reset by switching off and then switching on the supply voltage to the module.

CONNECTIONS:

Supply:

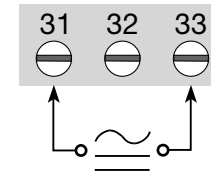

Inputs:

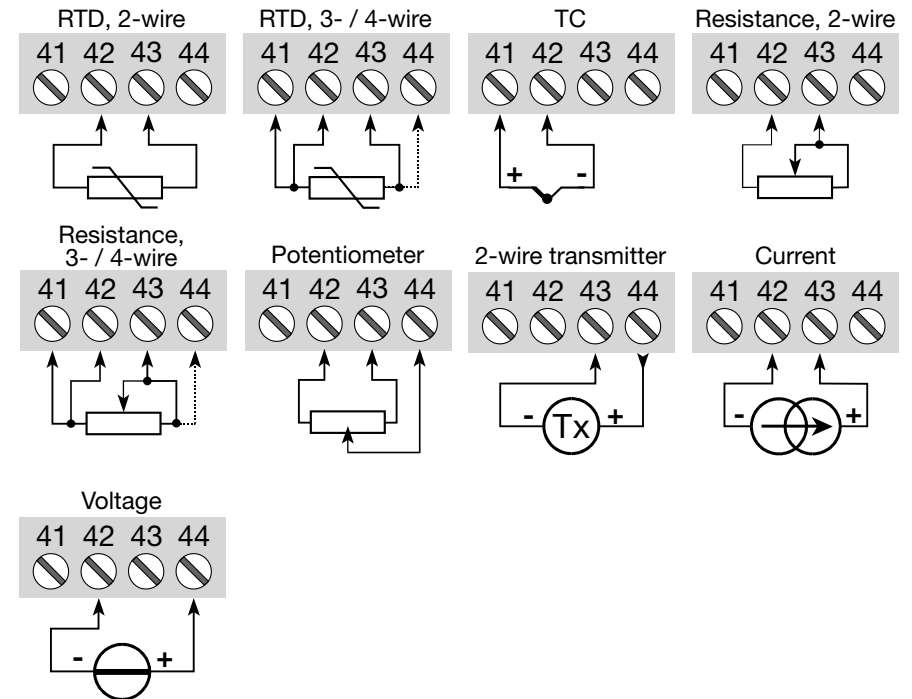

Outputs:

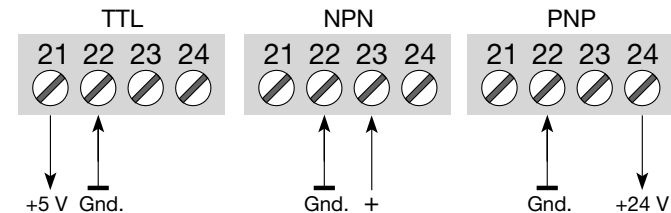

BLOCK DIAGRAM:

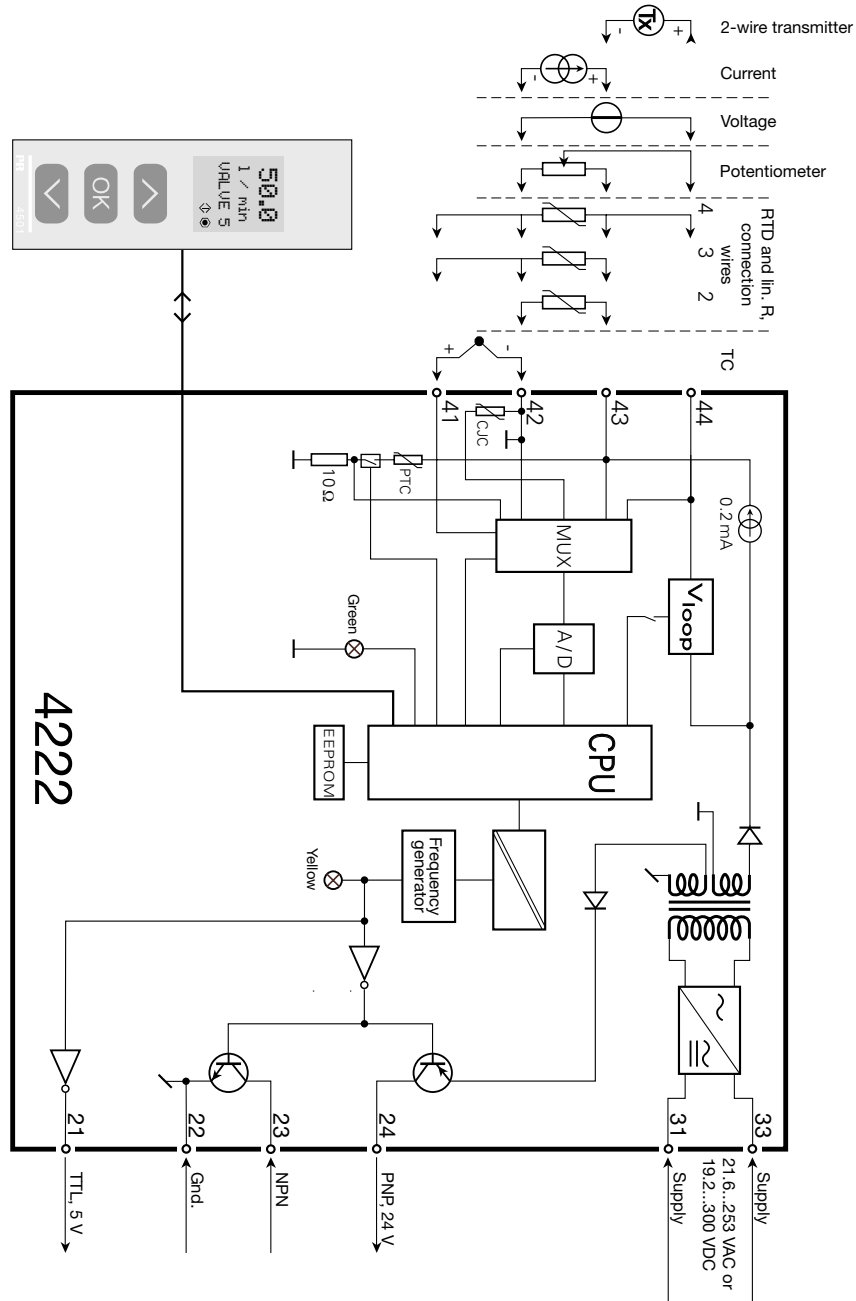

CONFIGURATION / OPERATING THE FUNCTION KEYS

Documentation for routing diagram.

In general:

When configuring the 4222, you will be guided through all parameters and you can choose the settings which fit the application. For each menu there is a scrolling help text which is automatically shown in line 3 on the display.

Configuration is carried out by using the 3 function keys:

- ⬆ will increase the numerical value or choose the next parameter
- ⬇ will decrease the numerical value or choose the previous parameter
- Ⓞ will save the chosen value and proceed to the next menu

When configuration is completed, the display will return to the default state 1.0.

Pressing and holding Ⓞ will return to the previous menu or return to the default state (1.0) without saving the changed values or parameters.

If no key is activated for 1 minute, the display will return to the default state (1.0) without saving the changed values or parameters.

Further explanations:

Password protection: Programming access can be blocked by assigning a password. The password is saved in the converter in order to ensure a high degree of protection against unauthorised modifications to the configuration. Default password 2008 allows access to all configuration menus.

Signal and sensor error info via display front 4501

Sensor error (see limits in the table) is displayed as SE.BR (sensor break) or SE.SH (sensor short). Signals outside the selected range (not sensor error, see table for limits) are displayed as IN.LO indicating low input signal or IN.HI indicating high input signal. The error indication is displayed in line 3 as text and at the same time the backlight flashes. Line 4 of the display is a status line which displays COM (flashing bullet) indicating correct functioning of 4501 and arrow up/down which indicates tendency readout of the input signal.

Signal and sensor error indication without display front

Status of the unit can also be read from the green LED in the front of the module.

Green flashing LED 13 Hz indicates normal operation.

Green flashing LED 1 Hz indicates sensor error.

Steady green LED indicates internal error.

Advanced functions

The unit gives access to a number of advanced functions which can be reached by answering "Yes" to the point "adv.set".

Display setup: Here you can adjust the brightness contrast and the backlight. Setup of TAG numbers with 6 alphanumeric. Selection of readout in line 3 of the display. This line can either show the digital output or the TAG number.

Two-point process calibration: The unit can be process-calibrated in 2 points to fit a given input signal. A low input signal (not necessarily 0%) is applied and the actual value is entered. Then a high signal (not necessarily 100%) is applied and the actual value is entered. If you accept to use the calibration, the unit will work according to this new adjustment. If you later reject this menu point or choose another type of input signal the unit will return to factory calibration.

Process simulation function: If you say "Yes" to the point "EN.SIM" it is possible to simulate an input signal by means of the arrow keys and thus control the output signal up and down. When you finalise the point with , the unit returns to normal mode.

Password: Here you can choose a password between 0000 and 9999 in order to protect the unit against unauthorised modifications to the configuration. The unit is delivered default without password. If you have locked the unit with a password by mistake, you can always open the menu by using the master password 2008.

Language: In the menu "lang.setup" you can choose between 7 different language versions of help texts that will appear in the menu. You can choose between UK, DE, FR, IT, ES, SE and DK.

Auto diagnosis

The unit performs an advanced auto diagnosis of the internal circuits.

The following possible errors can be displayed in the front unit 4501.

CJ.ER - CJC sensor defect or CJC temperature outside range

FL.ER - Flash error

NO.CO - Connection error

IN.ER - Error levels on input

TY.ER - Configuration in 4501 does not match this product type

Selection of units

After choosing the input signal type you can choose the process units which will be shown in the display (see table). By selection of temperature input the process value is always displayed in Celsius or Fahrenheit. This is selected in the menu point after selection of temperature input.

ROUTING DIAGRAM

If no key is activated for 1 minute, the display will return to the default state 1.0 without saving configuration changes.

- ⊕ Increase value / choose next parameter
- ⊖ Decrease value / choose previous parameter
- ⊙ Save the chosen value and proceed to the next menu
- ⊙ Hold ⊙ Back to previous menu / return to menu 1.0 without saving

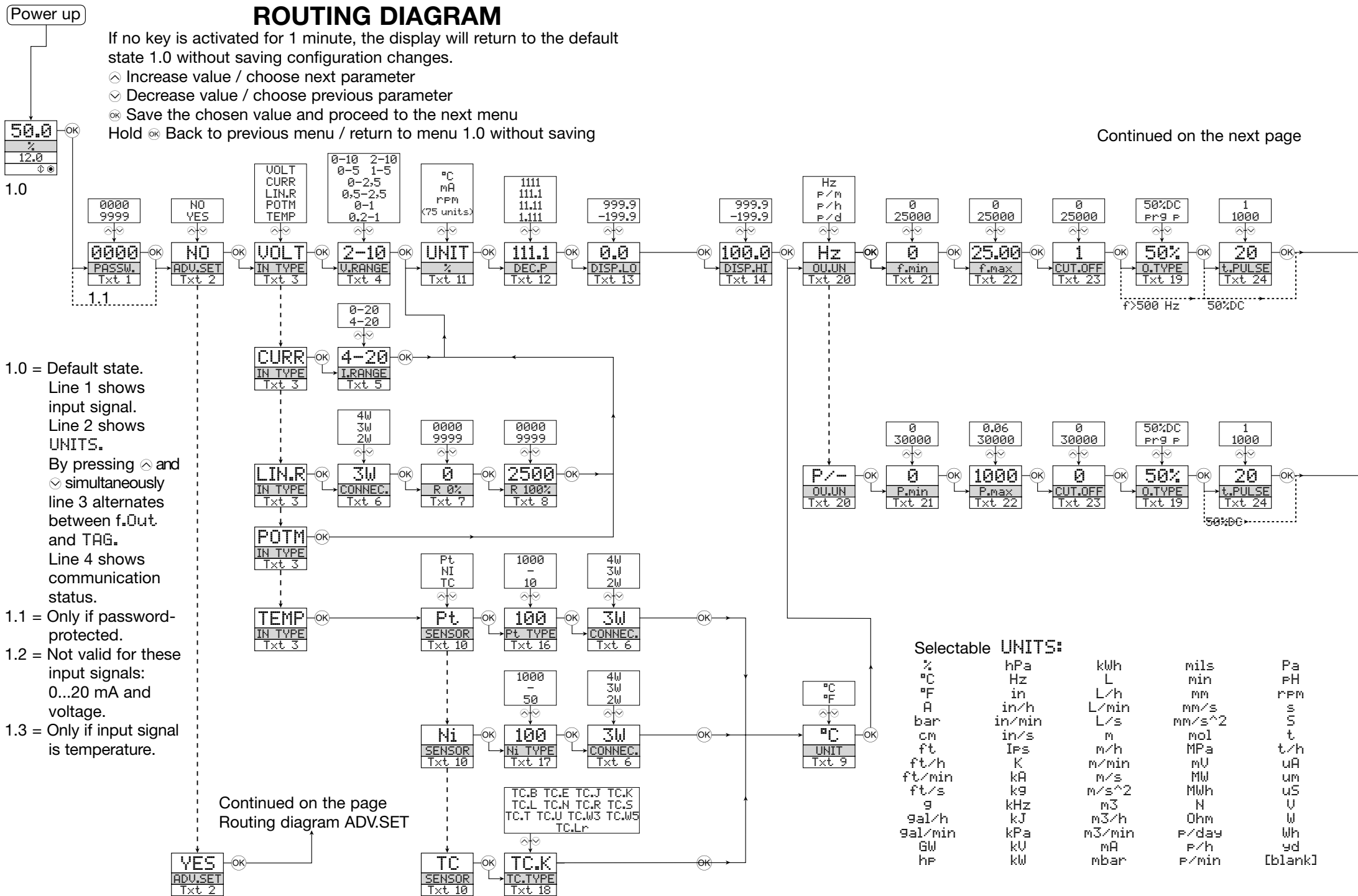

Continued on the next page

- 1.0 = Default state. Line 1 shows input signal. Line 2 shows UNITS. By pressing ⊕ and ⊖ simultaneously line 3 alternates between f.Out. and TAG. Line 4 shows communication status.
- 1.1 = Only if password-protected.
- 1.2 = Not valid for these input signals: 0...20 mA and voltage.
- 1.3 = Only if input signal is temperature.

Continued on the page
Routing diagram ADV.SET

Selectable UNITS:

%	hPa	kWh	mils	Pa
°C	Hz	L	min	PH
°F	in	L/h	mm	rPM
A	in/h	L/min	mm/s	s
bar	in/min	L/s	mm/s^2	S
cm	in/s	m	mol	t
ft	Ips	m/h	MPa	t/h
ft/h	K	m/min	nU	uA
ft/min	kA	m/s	MW	um
ft/s	k9	m/s^2	MWh	uS
g	kHz	m^3	N	V
gal/h	kJ	m^3/h	Ohm	W
gal/min	kPa	m^3/min	P/day	Wh
GW	kV	mA	P/h	yd
hp	kW	mbar	P/min	[blank]

Continued from previous page

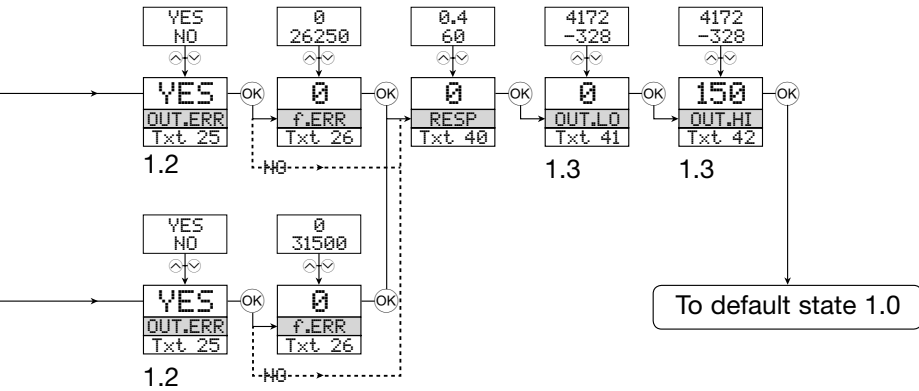

1.2 = Not valid for these input signals:
0...20 mA and voltage.
1.3 = Only if input signal is temperature.

ROUTING DIAGRAM

Advanced settings (ADV.SET)

2.0 In the submenu simulation (SIM) you must press **OK** to return to the default state 1.0.

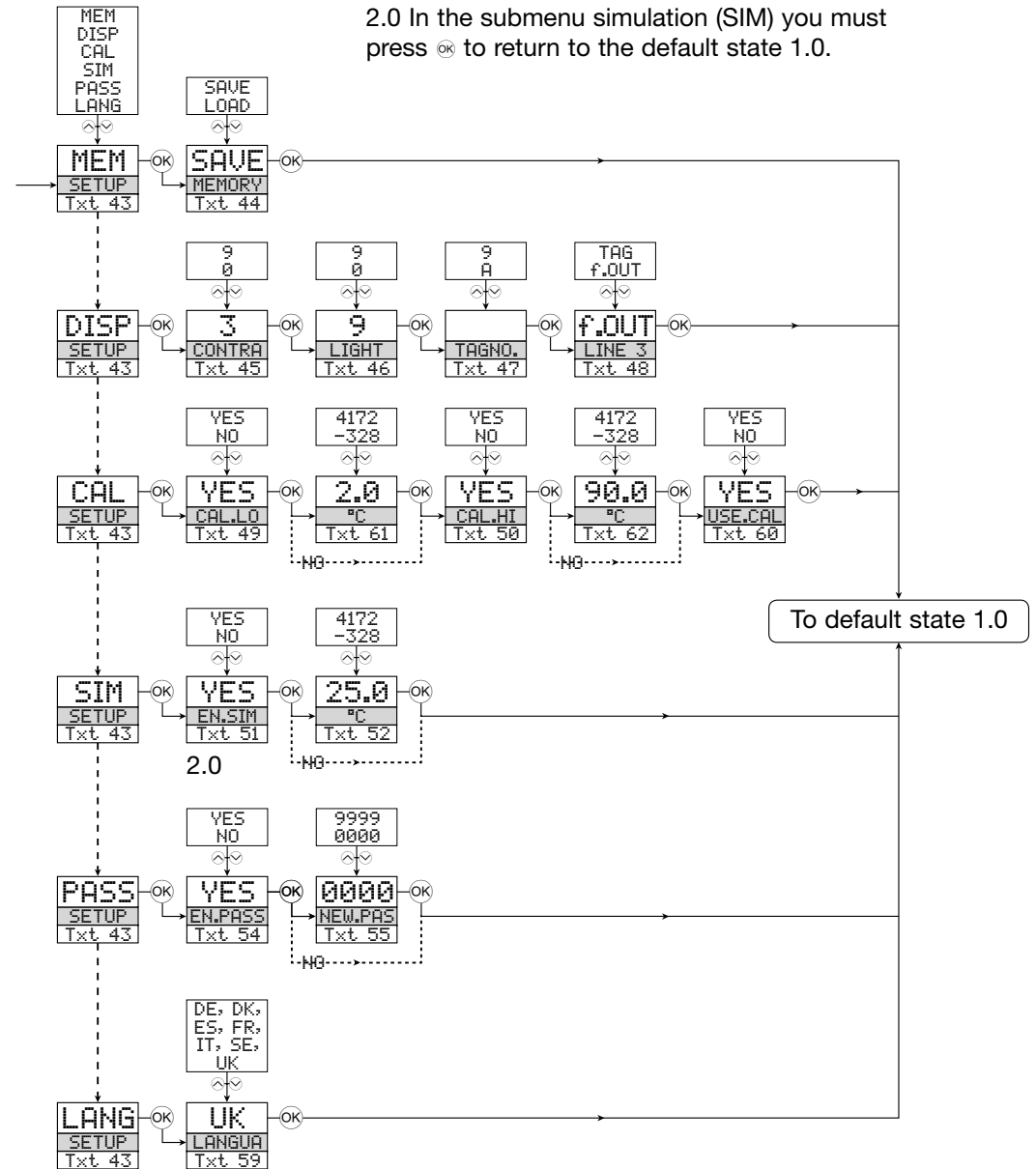

Scrolling help text in display line 3

- [01] Set correct password
- [02] Enter advanced setup menu?
- [03] Select temperature input
 - Select potentiometer input
 - Select linear resistance input
 - Select current input
 - Select voltage input
- [04] Select 0.0-1 V input range
 - Select 0.2-1 V input range
 - Select 0-2.5 V input range
 - Select 0.5-2.5 V input range
 - Select 0-5 V input range
 - Select 1-5 V input range
 - Select 0-10 V input range
 - Select 2-10 V input range
- [05] Select 0-20 mA input range
 - Select 4-20 mA input range
- [06] Select 2-wire sensor connection
 - Select 3-wire sensor connection
 - Select 4-wire sensor connection
- [07] Set 0% resistance value
- [08] Set 100% resistance value
- [09] Select Celsius as temperature unit
 - Select Fahrenheit as temperature unit
- [10] Select TC sensor type
 - Select Ni sensor type
 - Select Pt sensor type
- [11] Select display unit
- [12] Select decimal point position
- [13] Set display readout low
- [14] Set display readout high
- [16] Select Pt10 as sensor type
 - Select Pt20 as sensor type
 - Select Pt50 as sensor type
 - Select Pt100 as sensor type
 - Select Pt200 as sensor type
 - Select Pt250 as sensor type
 - Select Pt300 as sensor type
 - Select Pt400 as sensor type
 - Select Pt500 as sensor type
 - Select Pt1000 as sensor type
- [17] Select Ni50 as sensor type
 - Select Ni100 as sensor type
 - Select Ni120 as sensor type
 - Select Ni1000 as sensor type
- [18] Select TC-B as sensor type
 - Select TC-E as sensor type
 - Select TC-J as sensor type
 - Select TC-K as sensor type
 - Select TC-L as sensor type
 - Select TC-N as sensor type
 - Select TC-R as sensor type
 - Select TC-S as sensor type
 - Select TC-T as sensor type
 - Select TC-U as sensor type
 - Select TC-W3 as sensor type
 - Select TC-W5 as sensor type
 - Select TC-Lr as sensor type

- [19] Select 50% duty cycle output
 - Select programmable pulse time
- [20] Select Hz as output unit
 - Select pulses/minute as output unit
 - Select pulses/hour as output unit
 - Select pulses/day as output unit
- [21] Set output frequency for 0% input
- [22] Set output frequency for 100% input
- [23] Set low cut-off frequency
- [24] Set pulse time in milliseconds
- [25] Select no error action - output undefined at error
 - Select output at specific frequency on input error
- [26] Set output frequency on input error
- [40] Set response time in seconds
- [41] Set temperature for frequency output low
- [42] Set temperature for frequency output high
- [43] Enter language setup
 - Enter password setup
 - Enter simulation mode
 - Perform process calibration
 - Enter display setup
 - Perform memory operations
- [44] Load saved configuration into module
 - Save configuration in display front
- [45] Adjust LCD contrast
- [46] Adjust LCD backlight
- [47] Write a 6-character device TAG
- [48] Output frequency is shown in display line 3
 - Device TAG is shown in display line 3
- [49] Calibrate input low to process value?
- [50] Calibrate input high to process value?
- [51] Enter simulation mode?
- [52] Simulate input value
- [54] Enable password protection?
- [55] Set new password
- [59] Select language
- [60] Use process calibration values?
- [61] Set value for low calibration point
- [62] Set value for high calibration point

CONVERTISSEUR I/f UNIVERSEL

PREASY 4222

SOMMAIRE

Avertissements	50
Consignes de sécurité	51
Déclaration de conformité	53
Démontage du SYSTEME 4000	54
Options avancées	55
Applications	55
Caractéristiques techniques	55
PR 4501 Indicateur / façade de programmation	56
Applications	57
Références de commande	58
Spécifications électriques	58
Configuration de la détection erreur capteur	61
Indications dans le 4501 :	
Indication de dépassement d'échelle	61
Limites de la détection erreur capteur	62
Limites du traitement de signaux	62
Indications erreur matériel	62
Connexions	63
Schéma de principe	64
Configuration / utilisation des touches de fonction	65
Diagramme de programmation	68
Diagramme de programmation,	
réglage avancé (ADV.SET)	71
Menu déroulant en ligne 3 de l'indicateur	72

DK ▶ PR electronics A/S tilbyder et bredt program af analoge og digitale signalbehandlingsmoduler til industriel automation. Vores kompetenceområder omfatter: Isolation, Displays, Ex-barrierer, Temperatur samt Universal-moduler. Alle produkter opfylder de strengeste internationale standarder, og størstedelen integrerer den patenterede STREAM-SHIELD teknologi, der sikrer driftssikkerhed i selv de værste omgivelser. Vores motto »Signals the Best« er indbegrebet af denne filosofi – og din garanti for kvalitet.

UK ▶ PR electronics A/S offers a wide range of analogue and digital signal conditioning modules for industrial automation. Our areas of competence include: Isolation, Displays, Ex barriers, Temperature, and Universal Modules. All products comply with the most exacting international standards and the majority feature our patented STREAM-SHIELD technology ensuring reliability in even the worst of conditions. »Signals the Best« is the epitome of our philosophy – and your guarantee for quality.

FR ▶ PR electronics A/S offre une large gamme de produits pour le traitement des signaux analogiques et numériques dans tous les domaines industriels. Nos compétences s'étendent des transmetteurs de température aux afficheurs, des isolateurs aux barrières SI, jusqu'aux modules universels. Tous nos produits sont conformes aux normes internationales les plus strictes et la majorité d'entre eux répondent même à la technologie brevetée STREAM-SHIELD qui garantit un fonctionnement fiable sous les conditions les plus défavorables. Notre devise »SIGNALS the BEST« c'est notre ligne de conduite - et pour vous l'assurance de la meilleure qualité.

DE ▶ PR electronics A/S verfügt über ein breites Produktprogramm an analogen und digitalen Signalverarbeitungsmodulen für die industrielle Automatisierung. Unsere Kompetenzbereiche umfassen: Displays, Temperaturtransmitter, Ex- und galvanische Signaltrenner, und Universalgeräte. Alle Produkte von PR electronics werden in Übereinstimmung mit den strengsten internationalen Normen produziert. Für die Mehrzahl aller Produkte garantiert die patentierte STREAM-SHIELD Technologie höchste Zuverlässigkeit auch unter schwierigsten Einsatzbedingungen. »Signals the Best« ist Ihre Garantie für Qualität!

Subsidiaries

France
PR electronics Sarl
Zac du Chêne, Activillage 2, allée des Sorbiers
F-69500 Bron
sales@preelectronics.fr
tel. +33 (0) 4 72 14 06 07
fax +33 (0) 4 72 37 88 20

Germany
PR electronics GmbH
Bamlerstraße 92
D-45141 Essen
sales@preelectronics.de
tel. +49 (0) 201 860 6660
fax +49 (0) 201 860 6666

Italy
PR electronics S.r.l.
Via Giulietti, 8
IT-20132 Milano
sales@preelectronics.it
tel. +39 02 2630 6259
fax +39 02 2630 6283

Spain
PR electronics S.L.
Avda. Meridiana 354, 9^a B
E-08027 Barcelona
sales@preelectronics.es
tel. +34 93 311 01 67
fax +34 93 311 08 17

Sweden
PR electronics AB
August Barks gata 6A
S-421 32 Västra Frölunda
sales@preelectronics.se
tel. +46 (0) 3149 9990
fax +46 (0) 3149 1590

UK
PR electronics Ltd
Fairlie Quay Enterprise Park
Main Road, Fairlie
Ayrshire, KA29 0AS
sales@preelectronics.co.uk
tel. +44 (0) 1475 568 000
fax +44 (0) 1475 568 222

USA
PR electronics Inc
16776 Bernardo Center Drive
Suite 203
San Diego, California 92128
sales@preelectronics.com
tel. +1 858 521 0167
fax +1 858 521 0945

Head office

Denmark
PR electronics A/S
Lerbakken 10
DK-8410 Rønne
www.preelectronics.com
sales@preelectronics.dk
tel. +45 86 37 26 77
fax +45 86 37 30 85

