

Horizontal Float Switch

BR-LKS-3312



Features

Compact design, simple electro-mechanical device for liquid level switching in high and low-level applications. These float switches consist of a reed switch and a pivoted actuator magnet and can be used for N/O or N/C operation. The switch action can be reversed rotating the switch through 180°.

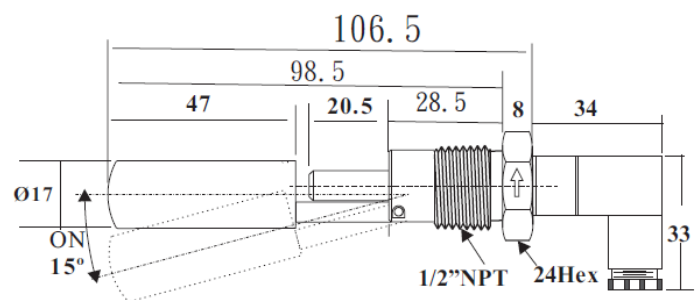

Specification

Mounting Style	External
Mounting thread	½" NPT
Stem material	SUS 304
Float material	SUS 316
Operating temperature	-40°C to +120°C
Maximum pressure	10 bar
Float specific gravity	0.7
Maximum switching voltage	300VAC/350VDC
Maximum switching current	0.5A AC or 0.7A DC
Maximum carry current	2.5A
Contact rating	50W (70VA)
Switch mode	N.O / N.C on dry condition
Electrical connection	9.4mm industry standard C connector

Free Call 0800 323 327

ECEFAST NZ LIMITED NZBN: 9429037885434

sales@ecefast.co.nz

www.ecefast.co.nz