



Principal characteristics

- The transducer is designed to satisfy extreme applicative demands in terms of mechanical strength.
- The 10 mm diameter rod, large steel joints, and reinforced structure make this series mechanically ideal for metalworking, woodworking, and ceramics.
- Installation is simplified by the lack of electrical signal variation at output outside theoretical electrical stroke.
- The structure based on self-aligning and weight-bearing ball joints permits assembly with free movement of the transducer axle.

TECHNICAL DATA

Useful electrical stroke (C.E.U.)	50/100/130/150/175/200/225/275/300/360/375/400/450/500/600/750
Independent linearity (within C.E.U.)	± 0,05%
Resolution	infinite
Repeatability	0,01 mm
Protection	IP65
Displacement speed	≤ 5 m/s
Displacement force	≤ 10 N
Life	>25x10 ⁶ strokes, or 100x10 ⁶ operations, whichever is less (within C.E.U.)
Vibrations	5...2000Hz, A _{max} = 0,75 mm a _{max} = 20 g
Shock	50 g, 11ms.
Tolerance on resistance	± 20%
Recommended cursor current	< 0,1 μA
Maximum cursor current	10mA
Max. applicable voltage	60V
Electrical isolation	>100MΩ a 500V~, 1bar, 2s
Dielectric strength	< 100 μA a 500V~, 50Hz, 2s, 1bar
Dissipation at 40°C (0W at 120°C)	3W
Actual Temperature Coefficient of the output voltage	< 1,5ppm/°C
Working temperature	-30...+100°C
Storage temperature	-50...+120°C
Case material	Anodised aluminium Nylon 66 G 25
Control rod material	Stainless steel AISI 303
Fixing	2 selfloading and selfaligning ball-joints

MECHANICAL DIMENSIONS

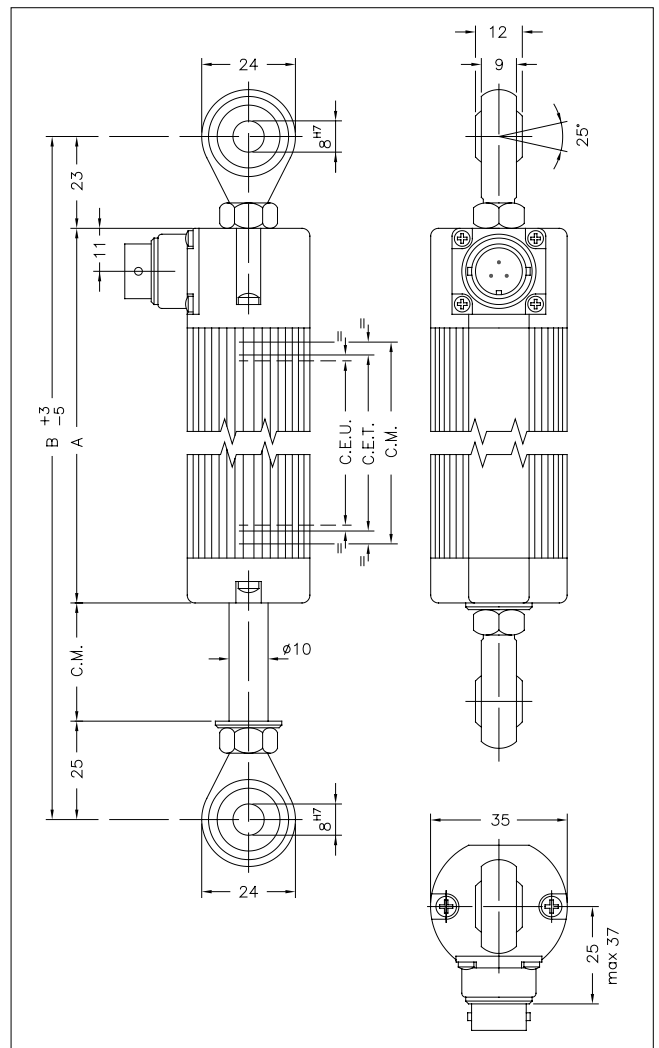

Important: all the data reported in the catalogue linearity, lifetime, temperature coefficient are valid for a sensor utilization as a ratiometric device with a max current across the cursor $I_c \leq 0.1 \mu A$.

MECHANICAL / ELECTRICAL DATA

MODEL		50	100	130	150	175	200	225	275	300	360	375	400	450	500	600	750	
Useful electrical stroke (C.E.U.) +3/-0	mm	50	100	130	150	175	200	225	275	300	360	375	400	450	500	600	750	
Theoretical electrical stroke (C.E.T.) ± 1	mm	C.E.U. + 3					C.E.U. + 4					364	380	406	457	508	609	762
Resistance (C.E.T.)	kΩ	5					5					5	5	5	5	5	5	10
Mechanical stroke (C.M.)	mm	C.E.U. + 9					C.E.U. + 10					370	386	412	463	518	619	772
Case length (A)	mm	C.E.U. + 129					C.E.U. + 130					496	512	538	589	664	765	918
Min. distance between ball-joints (B)	mm	C.E.U. + 177					C.E.U. + 178					544	560	586	637	712	813	966

ELECTRICAL CONNECTIONS

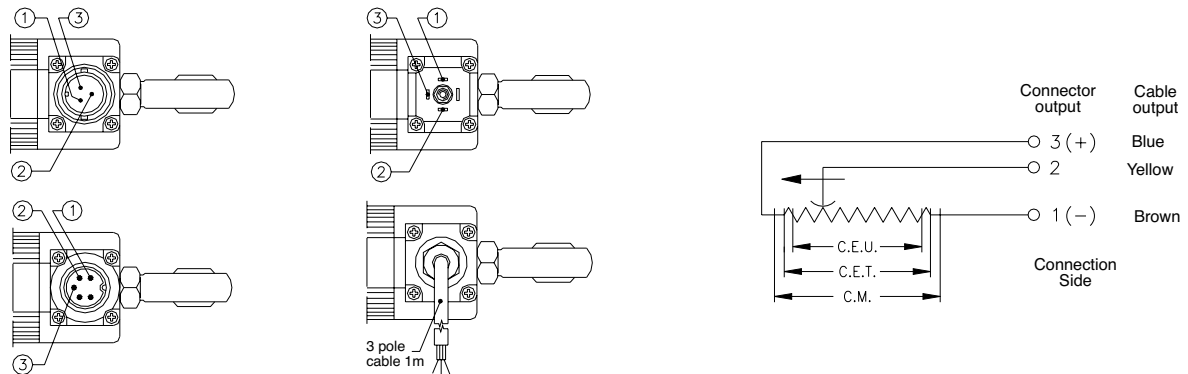

INSTALLATION INSTRUCTIONS

- Respect the indicated electrical connections (DO NOT use the transducer as a variable resistance)
- When calibrating the transducer, be careful to set the stroke so that the output does not drop below 1% or rise beyond 99% of the supply voltage.

ORDER CODE

Displacement transducer	PC																		
3-pole connector output	H																		
4-pole connector output	M																		
DIN43650 ISO4400																			
5-pole connector output	B																		
DIN45322																			
3-pole PVC cable output	F																		
3x0,25 1m																			

Model

Ex.: **PC - M - 275**

Displacement transducer model PC, 4 pole connector output
DIN43650 - ISO 4400, useful electrical stroke (C.E.U.) 275mm

OPTIONAL ACCESSORIES

4-pin 90° radial female PCM connector DIN43650 IP65 clamp PG9 for ø6 - ø8 mm wire	CON008
3-pin axial female PCH connector IP40 clamp for wire ø4 - ø6 mm	CON002
5-pin axial female PCB connector DIN43322 IP40 clamp for wire ø4 - ø6 mm	CON011
5-pin axial female PCB connector DIN43322 IP65 clamp PG7 for wire ø4 - ø6 mm	CON012
5-pin 90° radial female PCB connector DIN43322 IP40 clamp for wire ø4 - ø6 mm	CON013

GEFRAN spa reserves the right to make any kind of design or functional modification at any moment without prior notice

GEFRAN

GEFRAN spa
via Sebina, 74
25050 PROVAGLIO D'ISEO (BS) - ITALIA
tel. 0309888.1 - fax. 0309839063
Internet: <http://www.gefran.com>

DTS_PC_11-2012_ENG